

PARTING & GROOVING



PARTING & GROOVING



contents

Tool Selection Guide

Holder Selection Guide	B4
Insert Selection Guide	B12

Grades

B14

Toolholders

Blade Designation System	B18
Holder Designation System	B19
T-CLAMP Holder	B20
T-GROOVE Holder	B62
TOPCUT Holder	B63
QUADRUSH Holder	B65

Guide to Icons



➤ Holder Page



➤ Sleeve Page



➤ Insert Page



➤ Cutting Condition Page



➤ Technical Data Page

















Inserts and Solid Bars

Insert Designation System	B72
T-CLAMP Insert	B74
T-GROOVE Insert	B88
TOPMICRO Designation System	B89
TOPMICRO Sleeve and Solid Bar	B90
TOPCUT Designation System	B102
TOPCUT Insert	B103
QUADRUSH Designation System	B106
QUADRUSH Insert	B107
Tailor-made Designation System	B117
Tailor-made Insert	B118
Recommended Cutting Conditions	B125
Technical Data	B130







Tool Selection Guide

Parting and grooving holder

				T-CLAMP <small>ULTRA PLUS</small>			
				<u>TGB</u>	<u>TGB-MS</u>	<u>TGBR/L</u> <u>TGBR/L-D..R/L</u> <u>TGBR/L-TI-D..R/L</u>	<u>TGBFR/L</u>
Series							
Pages				B20	B21	B22	B25
Application	External	Parting		●	●	●	
		Grooving		●	●	●	
		Turning					
	Facing	Grooving					●
		Turning					
	Internal	Grooving					
		Turning					
	Profiling						
	Threading						
	Undercut						

Tool Selection Guide











Parting and grooving holder

T-CLAMP <small>ULTRA PLUS</small>			QUAD-RUSH	T-CLAMP <small>ULTRA PLUS</small>		
<u>TGER/L</u>	<u>TCER/L</u>	<u>TCFR/L</u>	<u>TQCR/L</u>	<u>C-ADAPTER</u>	<u>TTER/L-SH</u>	
						
B26	B29	B30	B31	B34	B37	
●	●		●	●	●	
●	●		●	●	●	
	●		○	●	●	
		●		●		
		●		●		
	●		○	●	●	
	●		○	●	●	
				●		

● Recommended, ○ Suitable







Tool Selection Guide

Parting and grooving holder

Series			T-CLAMP ULTRA PLUS				
			T-BURST TTER/L-SH-TB (High Pressure)	TTER/L-D	TTER/L	T-BURST TTER/L-TB (High Pressure)	
Pages			B38	B39	B41	B43	
Application	External	Parting		•	•	•	•
		Grooving		•	•	•	•
		Turning		•	•	•	•
	Facing	Grooving					
		Turning					
	Internal	Grooving					
		Turning					
	Profiling		•	•	•	•	
	Threading		•	•	•	•	
	Undercut						

Tool Selection Guide















Parting and grooving holder

T-CLAMP ULTRA PLUS					
<u>TTSER/L</u>	<u>TGSFR/L</u>	<u>TGFR/L</u>	<u>TTFR/L</u>	<u>TTFR/L-RN</u>	<u>TGFPR/L</u>
					
B44	B45	B46	B47	B48	B50
○					
●	●	●			●
●	●	○			○
	○	●	●	●	●
	○	●	●	●	●
○					
○					

● Recommended, ○ Suitable

Tool Selection Guide







Parting and grooving holder

				T-CLAMP <small>ULTRA PLUS</small>			
				<u>TTFPR/L</u>	<u>TGIFR/L</u>	<u>TTFIR/L</u>	<u>TTIR/L</u>
Series							
Pages				B51	B52	B53	B54
Application	External	Parting					
		Grooving					
		Turning					
	Facing	Grooving		●	●	●	
		Turning		●	●	●	
	Internal	Grooving					●
		Turning					●
	Profiling						
	Threading						
	Undercut						

Tool Selection Guide

Parting and grooving holder











T-CLAMP
ULTRA PLUS

<u>TTSIR/L</u>	<u>TGSIR/L</u>	<u>TGEUR/L</u>	<u>TGIUR/L</u>	<u>TTER/L-15A</u>	<u>TGIUR/L-15A</u>
					
B56	B57	B58	B59	B60	B61
				●	●
●	●				
●	●		○		
				●	●
		●	●		

● Recommended, ○ Suitable

Tool Selection Guide

Parting and grooving holder

Series				T-GROOVE	TOPCUT	QUAD-RUSH		
				TTLEN	TTVER/L TTVBR/L	TQBR/L	TQHR/L TQHPR/L	T-BURST <small>HIGH PRESSURE</small> TQHR/L-TB
Pages				B62	B63	B65	B66, B68	B67
Application	External	Parting			●	●	●	●
		Grooving		●	●	●	●	●
		Turning			●	○	○	○
	Facing	Grooving						
		Turning						
	Internal	Grooving						
		Turning						
	Profiling				○	○	○	
	Threading			●	○	○	○	
	Undercut							

● Recommended, ○ Suitable

Tool Selection Guide





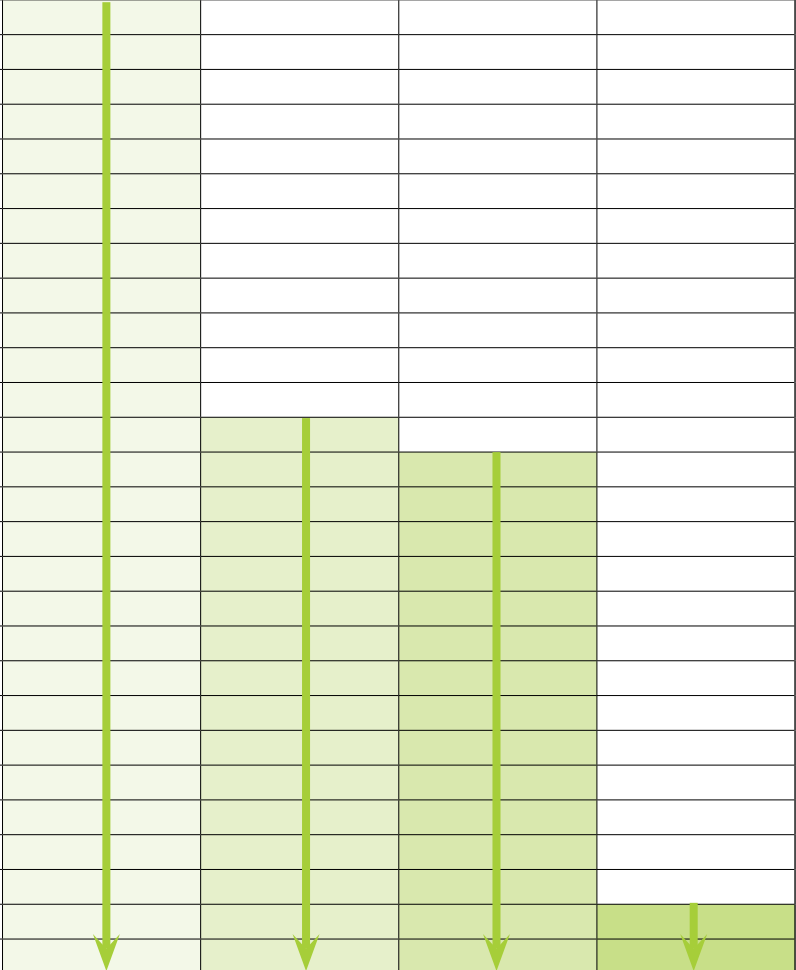









Internal application by diameter

Internal diameter (mm)	<i>TOPMICRO</i>	<i>TOPCAP</i>	TTSIR/L	TTIR/L
0				
0.6				
1				
2				
3				
4				
5				
6				
7				
8				
9				
10				
11				
12				
12.5				
13				
14				
15				
16				
17				
18				
19				
20				
21				
22				
23				
24				
25				
26				



Tool Selection Guide







Parting and grooving insert

Series			T-CLAMP <small>ULTRA PLUS</small>				
			TDC	TSC	TDJ	TSJ	
							
Pages			B74	B75	B76	B77	
Application	External	Parting		●	●	●	●
		Grooving		●	●	●	●
		Turning					
	Facing	Grooving		○	○	○	○
		Turning					
	Internal	Grooving		○	○	○	○
		Turning					
	Profiling						
	Threading						
	Undercut						

Tool Selection Guide

Parting and grooving insert

T-CLAMP
MULTI PLUS

<u>TDXU</u>	<u>TDXT</u>	<u>TDT</u>	<u>TDT - RU</u>	<u>TDT</u>	<u>TDFT</u>
					
B78	B78	B79	B81	B82	B83
○	○				○
●	●	●			○
●	●	●	●	●	○
●	●	○			●
●	●	○			●
●	●	○			
			●	●	
		○			
		○			

● Recommended, ○ Suitable







Tool Selection Guide

Parting and grooving insert

Series			T-CLAMP ULTRA PLUS				
			TDIT	TDIM	TDIP	TDA	
Pages			B83	B85	B86	B87	
Application	External	Parting		○	○	○	
		Grooving		○	●	●	
		Turning		○	●	●	●
	Facing	Grooving			○	○	
		Turning			○	○	
	Internal	Grooving		●	●	●	
		Turning		●	●	●	
	Profiling					●	
	Threading						
	Undercut		○				

Tool Selection Guide





Parting and grooving insert

T-CLAMP ULTRA PLUS	T-GROOVE	TOPMICRO	TOPCUT	QUAD-RUSH		
<u>TSA</u>	<u>TGUX</u>	<u>MIN.</u>	<u>TV..</u>	<u>TQJ</u>	<u>TQC</u>	<u>TQS</u>
						
B87	B88	B92	B103	B107	B111	B113
			●	●	●	●
	●		●	●	●	●
●			●	●	●	●
		●				
		●				
●		●		○	○	○
		●	●	●	●	●

● Recommended, ○ Suitable

Grades

Parting and grooving grades

Grades	ISO	Characteristics & applications
 TT7505 CVD coated	K01 – K15	<ul style="list-style-type: none"> • High speed turning & grooving of cast iron • Excellent wear resistant coated grade assures outstanding performance in high speed continue machining of cast iron
 TT6080 PVD coated	K05 – K25 H05 – H25	<ul style="list-style-type: none"> • General machining for gray and ductile cast iron • Finish and medium machining of hardened steel
 TT8125 CVD coated	P15 – P30	<ul style="list-style-type: none"> • For a wide range of turning and grooving • Very good combination of wear resistance and toughness • For general use on steels
TT5100 CVD coated	P20 – P35 M20 – M35	<ul style="list-style-type: none"> • Medium turning of low carbon steel and alloy steel • Medium & low speed machining of stainless steel
 TT9080 PVD coated	P20 – P40 M20 – M40 S20 – S40	<ul style="list-style-type: none"> • General machining of steel • General machining of stainless steel • General machining of heat-resistant alloy
TT7220 PVD coated	P25 – P45 M25 – M45	<ul style="list-style-type: none"> • Parting, grooving and turn grooving of steel • Parting, grooving and turn grooving of stainless steel
TT8020 PVD coated	P30 – P50 M30 – M50 S30 – S50	<ul style="list-style-type: none"> • Interrupted and rough machining of steel • Interrupted and rough machining of stainless steel • Low speed and interrupted machining of heat-resistant alloy
PV3030 PVD coated cermet	P05 – P20 M05 – M20 K05 – K20	<ul style="list-style-type: none"> • High speed finish machining of carbon steel, alloy steel, mild steel, mold steel and free-cutting steel • High speed finish and medium machining of austenite and martensite stainless steel • High speed finish & medium machining of gray cast iron, nodular and ductile cast iron
CT3000 Cermet	P10 – P20 M10 – M20 K10 – K20	<ul style="list-style-type: none"> • Finish machining of carbon steel, alloy steel, mild steel and mold steel. Good surface roughness • Finish machining of stainless steel. Good surface roughness • Finish machining of cast iron
K10 Carbide	K05 – K15 N05 – N15 S05 – S15	<ul style="list-style-type: none"> • General machining of cast iron • General machining of aluminum alloys and non-ferrous materials • General machining of heat-resistant alloy
AB30 Ceramic	K05 – K15 H05 – H15	<ul style="list-style-type: none"> • Continuous to light interrupted turning of cast iron without coolant • High speed turning of hardened steel (HRC 40-50)
KP300 PCD	N10 – N20	<ul style="list-style-type: none"> • General turning and grooving of non-ferrous materials • Excellent combination of wear resistance and toughness

Parting & Grooving Toolholders



Blade Designation System



1 TaeguTec

2 Application type

G	Grooving
T	Turning

3 Holder type

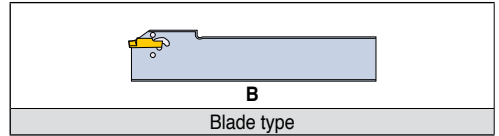

4 Machining type

F	Face grooving
---	---------------

5 Hand of holder

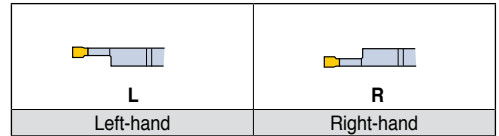

6 Blade height

	<p>26 = 26.0 mm 32 = 32.0 mm 45 = 45.0 mm 52 = 52.0 mm</p>
--	---

7 Insert size

	<p>2 = 2.0 mm 3 = 3.0 mm 4 = 4.0 mm 5 = 5.0 mm 6 = 6.0 mm</p>
--	---

8 Special code

S	Single type blade
MS	Blade for multi spindle machine
CL	Screw clamping

Holder Designation System

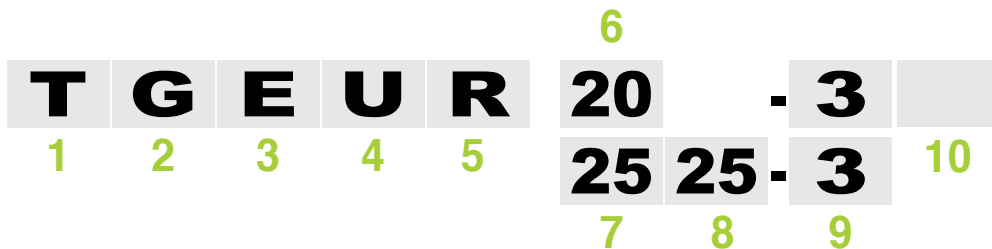

1 TaeguTec

2 Application type

G	Grooving
T	Turning



3 Machining type

E	External machining
I	Internal machining
F	Face machining

4 Holder shape

U	Undercutting
P	Perpendicular type

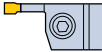
5 Hand of holder

	
L	R
Left-hand	Right-hand

6 Shank diameter

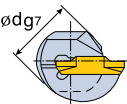
	10, 12, 16, 20, 25 32, 40, 50, etc
---	---------------------------------------

7 Shank height

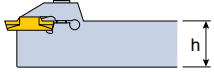
	10, 12, 16, 20, 25 32, 40, etc
---	-----------------------------------

8 Shank width

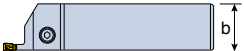
10, 12, 16, 20, 25, 32, 40, etc

9 Insert size

2, 3, 4, 5, 6, 8, 10

10 Special code

C	With coolant hole
T □	Overhang length
SH	Holder for swiss automatics
RN	Renewed type holder

Blades for parting and deep grooving

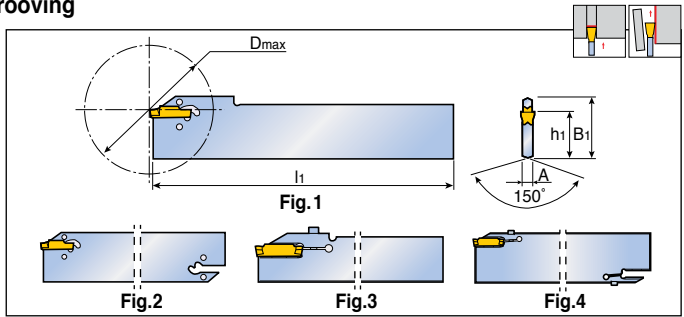

Designation	Insert seat size	Dimension (mm)						Block	Insert
		B1	li	h1	A	Dmax	Fig.		
TGB 26-1.4S⁽¹⁾	1	26	150	21.4	1.0 ⁽²⁾	26	1	TTBN/U...26	TDC / J / T
26-2S⁽¹⁾	2	26	150	21.4	1.8 ⁽²⁾	40	1	TTBN/U...26	TDXU / XT
26-3S⁽¹⁾	3	26	150	21.4	2.4	50	1	TTBN/U...26	TSC / J
26-4S⁽¹⁾	4	26	150	21.4	3.2	80	1	TTBN/U...26	B74-B83
32-1.4	1	32	150	24.9	1.0 ⁽²⁾	26	2	TTBN/U...32	
32-2	2	32	150	24.9	1.8 ⁽²⁾	50	2	TTBN/U...32	
32-3	3	32	150	24.9	2.4	100	2	TTBN/U...32	
32-4	4	32	150	24.9	3.2	100	2	TTBN/U...32	
32-5	5	32	150	24.9	4.0	120	2	TTBN/U...32	
32-6	6	32	150	24.9	5.2	120	2	TTBN/U...32	
45-4	4	45	150	38.1	3.2	120	2	TTBN/U...45	
32-8S-CL⁽¹⁾	8	32	150	24.9	6.2	80	3	TTBN/U...32	
52-8-CL	8	52	250	45.2	6.8	200	4	TTBN/U...52	

- ⁽¹⁾ Single ended blade
- ⁽²⁾ Thickness at DOC area only. Overall thickness is 2.4mm

Spare parts

Designation	Extractor	Screw	Wrench	
TGB 26-1.4S / 32-1.4	EDG-23B	-	-	
TGB 26 / 32 / 45	EDG-33B	-	-	
TGB 32-8S-CL	-	SH M4x0.7x20-MO	L-W3	
TGB 52-8-CL	-	SH M4x0.7x20-MO	L-W3	

- Extractor should be ordered separately

Blades for multi-spindle machines replacement for HSS and brazed tools

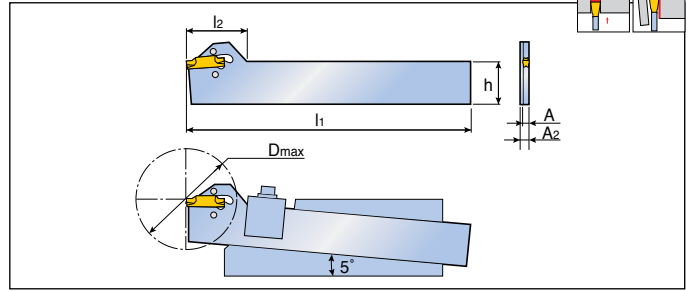

Designation	Insert seat size	Dimension (mm)						Insert
		h	l1	l2	A	A2	Dmax	
TGB 5-22-2-MS	2	22.2	150	32	1.8	3.2	42	TDC / J / T
5-22-3-MS	3	22.2	150	32	2.4	3.2	60	TDXU / XT
5-22-4-MS	4	22.2	150	32	3.2	3.2	80	TSC / J
								B74-B83

Spare parts

Designation	Extractor			
TGB-MS	EDG-33B			

• Extractor should be ordered separately

TGBR/L

Reinforced blades for parting and deep grooving

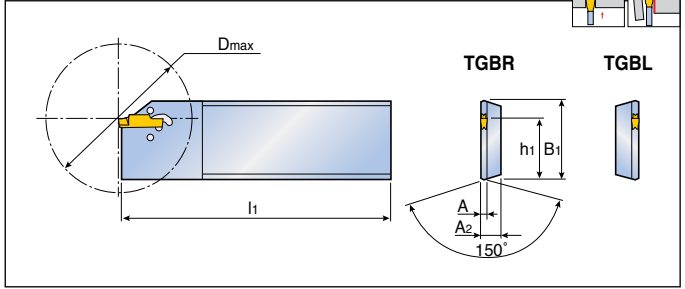
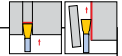

Designation	Insert seat size	Dimension (mm)						Block	Insert
		B1	l1	h1	A	A2	Dmax		
TGBR/L 32T24-2	2	32	110	24.9	1.8	8.0	42	TTBN/U..-32	TDC / J / T
32T33-3	3	32	110	24.9	2.4	8.0	60	TTBN/U..-32	TDXU / XT
32T41-4	4	32	110	24.9	3.2	10.0	80	TTBN/U..-32	TSC / J
									B74-B83

Spare parts

Designation	Extractor			
TGBR/L	EDG-33B			

• Extractor should be ordered separately

TGBR/L -D..R/L

Reinforced type blades with screw clamping

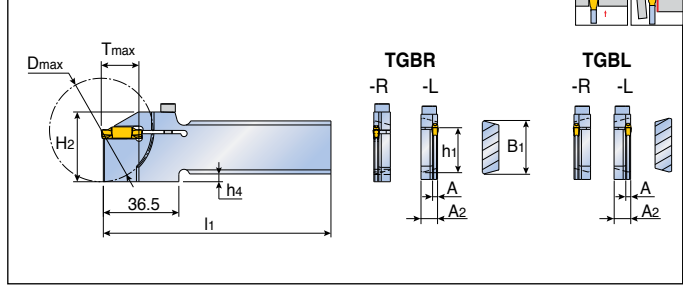

Designation	Insert seat size	Dimension (mm)										Block	Insert
		B1	A	A2	l1	h1	H2	h4	Tmax	Dmax			
TGBR 26-2-D50R ⁽¹⁾	2	26	1.8	8	110	21.4	33.7	3.6	18	50	TTBN/U...26	TDC / J / T TDXU / XT TSC / J B74-B83	
26-2-D50L ⁽²⁾	2	26	1.8	8	110	21.4	33.7	3.6	18	50	TTBN/U...26		
TGBL 26-2-D50R ⁽²⁾	2	26	1.8	8	110	21.4	33.7	3.6	18	50	TTBN/U...26		
26-2-D50L ⁽¹⁾	2	26	1.8	8	110	21.4	33.7	3.6	18	50	TTBN/U...26		
TGBR 26-3-D50R ⁽¹⁾	3	26	2.4	8	110	21.4	33.7	3.6	18	50	TTBN/U...26		
26-3-D50L ⁽²⁾	3	26	2.4	8	110	21.4	33.7	3.6	18	50	TTBN/U...26		
TGBL 26-3-D50R ⁽²⁾	3	26	2.4	8	110	21.4	33.7	3.6	18	50	TTBN/U...26		
26-3-D50L ⁽¹⁾	3	26	2.4	8	110	21.4	33.7	3.6	18	50	TTBN/U...26		
TGBR 32-2-D50R ⁽³⁾	2	32	1.8	8	120	24.9	33.7	-	18	50	TTBN/U...32		
32-2-D50L ⁽²⁾	2	32	1.8	8	120	24.9	33.7	-	18	50	TTBN/U...32		
TGBL 32-2-D50R ⁽²⁾	2	32	1.8	8	120	24.9	33.7	-	18	50	TTBN/U...32		
32-2-D50L ⁽³⁾	2	32	1.8	8	120	24.9	33.7	-	18	50	TTBN/U...32		
TGBR 32-3-D50R ⁽³⁾	3	32	2.4	8	120	24.9	33.7	-	18	50	TTBN/U...32		
32-3-D50L ⁽²⁾	3	32	2.4	8	120	24.9	33.7	-	18	50	TTBN/U...32		
TGBL 32-3-D50R ⁽²⁾	3	32	2.4	8	120	24.9	33.7	-	18	50	TTBN/U...32		
32-3-D50L ⁽³⁾	3	32	2.4	8	120	24.9	33.7	-	18	50	TTBN/U...32		

- ⁽¹⁾ for Traub machines, model TNC 30, TNM 28, TNS 26/30/42/112, TNA 300, TNK 260
- ⁽²⁾ for Tornos Bechler, model Emco 2000/20, 2000/26
- ⁽³⁾ for Traub machines, model TNC 42/65, TNM 42/65, TNS 42/60/65, TNA 300/400

Spare parts

Designation	Screw	Wrench		
	TGBR/L -DR/L	SH M4x0.7x16	L-W3	

TGBR/L -TI-D..R/L



Reinforced type blades with screw clamping for traub and index machines

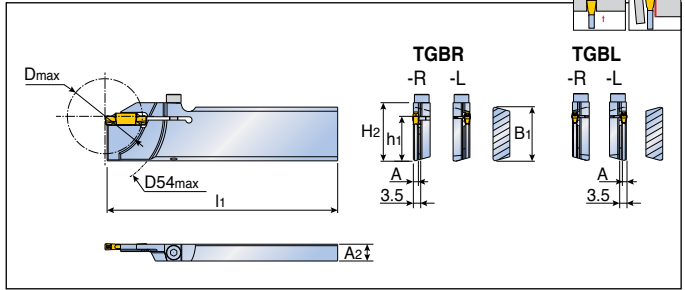

Designation	Insert seat size	Dimension (mm)							Block	Insert
		B1	A	A2	l1	h1	H2	Dmax		
TGBR/L 26-2TI-D36R	2	26	1.6	8	110	21.4	27.9	36	TTBN/U..-26	TDC / J / T
26-2TI-D36L	2	26	1.6	8	110	21.4	27.9	36	TTBN/U..-26	TDXU / XT
26-3TI-D36R	3	26	2.4	8	110	21.4	27.9	36	TTBN/U..-26	TSC / J
26-3TI-D36L	3	26	2.4	8	110	21.4	27.9	36	TTBN/U..-26	B74-B83

Spare parts

Designation	Screw	Wrench		
TGBR/L -TI-DR/L	SH M4x0.7x16	L-W3		

Blades for face grooving

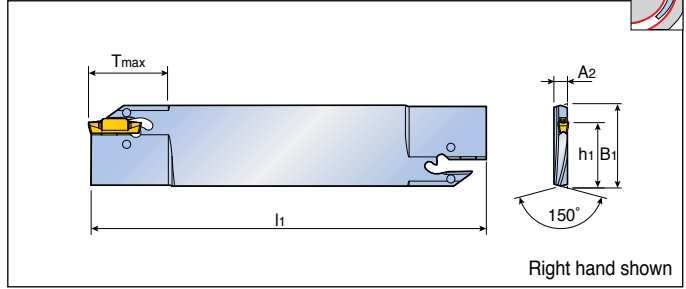

Designation	Insert seat size	Dimension (mm)							Block	Insert
		B ₁	l ₁	h ₁	A ₂	T _{max}	D _{min}	D _{max}		
TGBFR/L 32T20-40-60-3	3	32	150	24.9	5.2	20	40	60	TTBN/U...32	TDC / J / T TDXU / XT / FT TSC / J B74-B83
32T20-54-80-3	3	32	150	24.9	5.2	20	54	80	TTBN/U...32	
32T25-74-120-3	3	32	150	24.9	5.2	25	74	120	TTBN/U...32	
32T25-114-180-3	3	32	150	24.9	5.2	25	114	180	TTBN/U...32	
32T25-40-60-4	4	32	150	24.9	5.2	25	40	60	TTBN/U...32	
32T25-50-80-4	4	32	150	24.9	5.2	25	50	80	TTBN/U...32	
32T30-70-130-4	4	32	150	24.9	5.2	30	70	130	TTBN/U...32	
32T30-120-200-4	4	32	150	24.9	5.2	30	120	200	TTBN/U...32	
32T30-200-4	4	32	150	24.9	5.2	30	200	∞	TTBN/U...32	
32T32-60-95-5	5	32	150	24.9	5.2	32	60	95	TTBN/U...32	
32T35-85-140-5	5	32	150	24.9	5.2	35	85	140	TTBN/U...32	
32T35-130-250-5	5	32	150	24.9	5.2	35	130	250	TTBN/U...32	
32T35-250-5	5	32	150	24.9	5.2	35	250	∞	TTBN/U...32	
32T32-80-180-6	6	32	150	24.9	5.2	32	80	180	TTBN/U...32	
32T38-168-300-6	6	32	150	24.9	5.2	38	168	300	TTBN/U...32	
32T38-300-6	6	32	150	24.9	5.2	38	300	∞	TTBN/U...32	

• Please check insert min. dia for face grooving [B49](#) page

Spare parts

Designation	Extractor			
TGBFR/L	EDG-33B			

• Extractor should be ordered separately

Parting and deep grooving

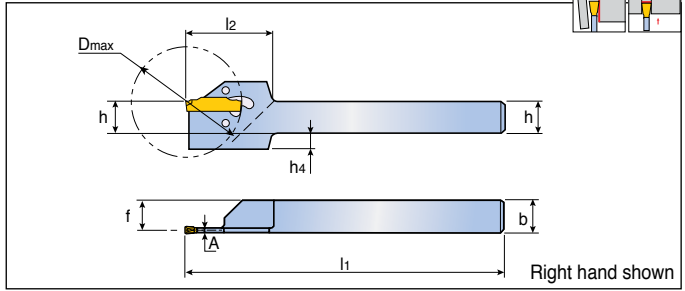

Designation	Insert seat size	Dimension (mm)							Dmax		Insert
		h	b	l ₁	f	l ₂	A	h ₄	TDJ/C	TSJ/C	
TGER/L 2020-1.4T10	1	20	20	125	19.5	31	1.0	-	20	20	TDC / J / T
1010-2	2	10	10	150	9.1	31	1.8	8	33	33	TDXU / XT
1212-2	2	12	12	150	11.1	31	1.8	6	35	35	TSC / J
1616-2	2	16	16	150	15.1	31	1.8	2	35	35	B74-B83
2012-2	2	20	12	150	11.1	31	1.8	-	35	35	
2020-2	2	20	20	150	19.1	31	1.8	-	35	35	
1212-3	3	12	12	150	10.8	31	2.4	6	38	40	
1616-3	3	16	16	150	14.8	31	2.4	2	38	45	
2020-3	3	20	20	125	18.8	31	2.4	-	38	45	
2525-3	3	25	25	150	23.8	31	2.4	-	38	45	
2020-4	4	20	20	125	18.4	33	3.2	-	38	55	
2525-4	4	25	25	150	23.4	33	3.2	-	38	55	

Spare parts

Designation	Extractor			
TGER/L.....-1.4T10	EDG-23B			
TGER/L.....-2	EDG-33B			
TGER/L.....-3	EDG-33B			
TGER/L.....-4	EDG-33B			

• Extractor should be ordered separately

Blocks for parting and deep grooving blades

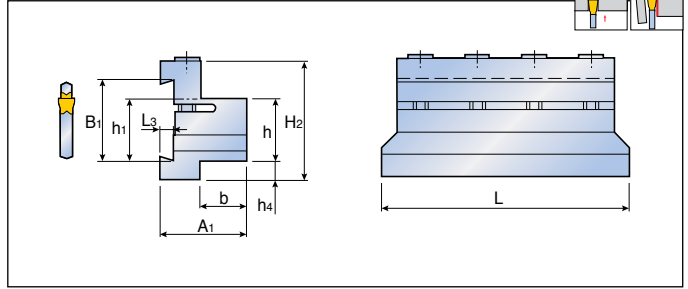

Designation	Dimension (mm)								
	B1	h1	h	h4	H2	L3	L	b	A1
TTBN 16-26	26	21.0	16	12	38	4.0	87	15	29
20-26	26	21.4	20	8	38	4.0	87	19	33
25-26	26	21.4	25	3	38	4.0	110	20	34
20-32	32	24.8	20	13	48	5.5	100	19	35
25-32	32	24.8	25	8	48	5.5	110	20	36
32-32	32	24.8	32	3	48	5.5	120	28	44
25-45	45	38.1	25	25	66	5.5	110	22	40
32-45	45	38.1	32	18	66	5.5	120	28	45
40-52	52	45.2	40	21	82	8.0	160	40	65

Spare parts

Designation	Screw	Wrench		
TTBN...26	SH M6x1.0x25	L-W5		
TTBN...32	SH M6x1.0x30	L-W5		
TTBN...45	SH M6x1.0x40	L-W5		
TTBN...52	SH M8x1.25x45	L-W6		



Blocks for parting and deep grooving blades

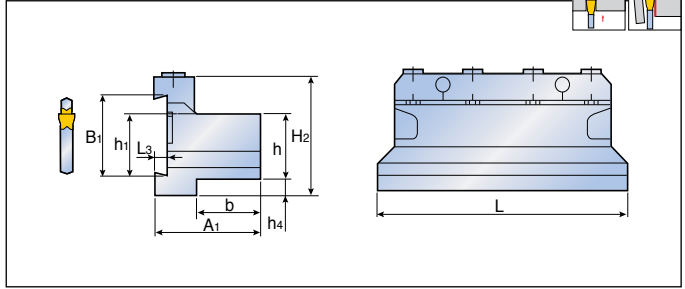

Designation	Dimension (mm)								
	B1	h1	h	h4	H2	L3	L	b	A1
TTBU 20-26	26	21.4	20	9	43	4.0	86	21	38
25-26	26	21.4	25	5	45	4.0	110	23	42
20-32	32	24.8	20	13	50	5.3	100	19	38
25-32	32	24.8	25	8	50	5.3	110	23	42
32-32	32	24.8	32	5	54	5.3	110	29	48
25-45	45	38.1	25	27	70	5.3	110	23	42
32-45	45	38.1	32	20	70	5.3	110	29	48

Spare parts

Designation	Screw	Clamp	Wrench	
TTBU 20-26	SR M6X30 DIN912	BKU- 86	L-W5	
TTBU 25-26	SR M6X30 DIN912	BKU-105	L-W5	
TTBU 20-32	SR M6X25 DIN912	BKU-100	L-W5	
TTBU 25-32	SR M6X25 DIN912	BKU-110	L-W5	
TTBU 32-32	SR M6X30 DIN912	BKU-110	L-W5	
TTBU 25/32-45	SR M6X30 DIN912	BKU-110	L-W5	



Cartridge for external turning and grooving

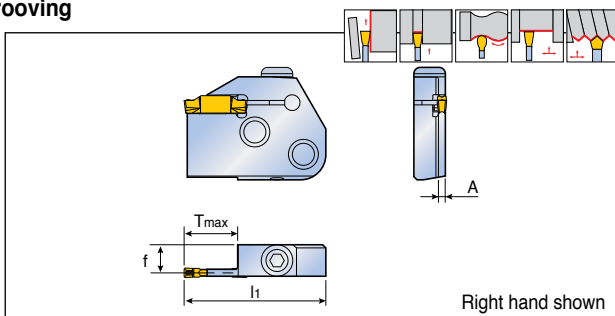

Designation	Insert seat size	Dimension (mm)				Insert	Holder
		l ₁	A	f	T _{max}		
TCER/L 1.4T12	1	41	1.0	9.5	12	TDJ 1.4	C.-TCHN
2T16	2	45	1.8	9.1	16	TDC ⁽¹⁾ / J ⁽¹⁾ / T	C.-TCHPN
2T22	2	51	1.8	9.1	22	TDXU / XT	TCHR/L
3T16	3	45	2.4	8.8	16	TSC ⁽¹⁾ / J ⁽¹⁾	TCHPR/L
3T22	3	51	2.4	8.8	22	B74-B83	B32-B35
4T16	4	45	3.0	8.5	16		
4T22	4	51	3.0	8.5	22		
5T20	5	49	4.0	8.0	20		
5T25	5	54	4.0	8.0	25		
6T20	6	49	5.0	7.5	20		
6T25	6	54	5.0	7.5	25		

- ⁽¹⁾ Insert for grooving only
- Ordering example: 2 pcs. TCER 3T16

Spare parts

Designation	Screw	Wrench		
TCER/L	BH M6x1x20	L-W4		

Cartridge for external face grooving and turning

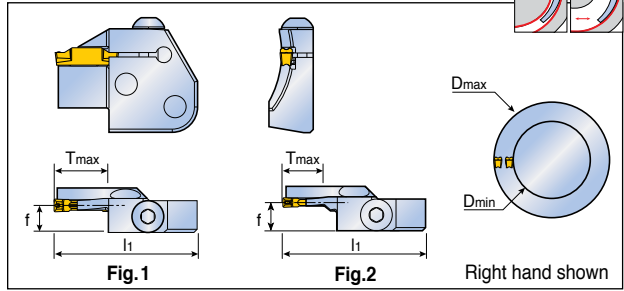

Designation	Insert seat size	Dimension (mm)					Fig.	Insert	Holder
		l ₁	f	T _{max}	D _{min}	D _{max}			
TCFR/L 3T12-40-55 RN	3	45	8.9	12	40	55	2	TDC ⁽¹⁾ / J ⁽¹⁾ / T	C..-TCHN
3T12-55-75 RN	3	45	8.9	12	55	75	2	TDXU / XT	C..-TCHPN
3T12-75-100 RN	3	45	8.9	12	75	100	2	TSC ⁽¹⁾ / J ⁽¹⁾	TCHR/L
3T12-100-140 RN	3	45	8.9	12	100	140	2	B74-B83	TCHPR/L
3T12-140-200 RN	3	45	8.9	12	140	200	2	B32-B35	
4T16-50-70 RN	4	45	8.5	16	50	70	1		
4T16-70-100 RN	4	45	8.5	16	70	100	1		
4T16-100-150 RN	4	45	8.5	16	100	150	1		
4T16-150-250 RN	4	45	8.5	16	150	250	1		
4T16-250 RN	4	45	8.5	16	250	∞	1		
5T20-55-80 RN	5	49	8.0	20	55	80	1		
5T20-80-120 RN	5	49	8.0	20	80	120	1		
5T20-120-180 RN	5	49	8.0	20	120	180	1		
5T20-180-300 RN	5	49	8.0	20	180	300	1		
5T20-300 RN	5	49	8.0	20	300	∞	1		
6T25-60-90 RN	6	55	7.5	25	60	90	1		
6T25-90-150 RN	6	55	7.5	25	90	150	1		
6T25-150-250 RN	6	55	7.5	25	150	250	1		
6T25-250-400 RN	6	55	7.5	25	250	400	1		
6T25-400 RN	6	55	7.5	25	400	∞	1		

- ⁽¹⁾ Insert for grooving only
- Ordering example: 5 pcs. TCFR 3T12-40-55RN
- Please check insert min. dia for face grooving [B49](#) page

Spare parts

Designation	Screw	Wrench		
TCFR/L	BH M6x1x20	L-W4		

TQCR/L

QUAD-RUSH

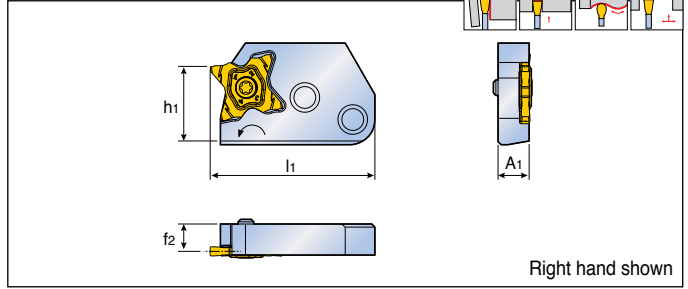

Cartridge for grooving, parting and recessing



Designation	Dimension (mm)					Insert	Holder
	f ₂ ⁽¹⁾	l ₁	W _{range}	h ₁	A ₁		
TQCR 27	8.8	53	0.5 ≤ W < 5.3	24	10	TQ.. 27...	C..-TCHN
TQCL 27	8.8	53	0.5 ≤ W < 5.3	24	10	TQ.. 27... B107-B116	C..-TCHPN TCHR/L TCHPR/L B32-B35

• ⁽¹⁾ "f₂" value is based on TQ.. 27 standard insert

Spare parts

Designation	Screw	Wrench		
				
TQCR 27	TS 50125IL	T 10 / 20		
TQCL 27	TS 50125I	T 10 / 20		

Parallel holders

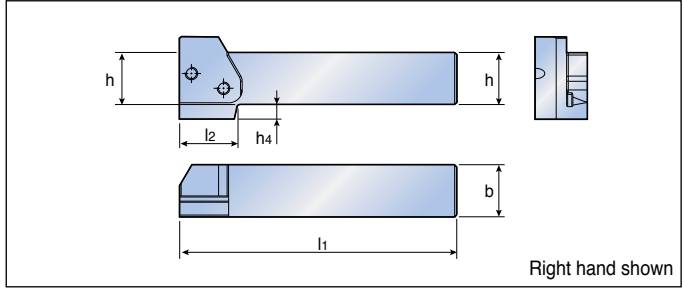

Designation	Dimension (mm)					Cartridge
	h	b	l ₁	l ₂	h ₄	
TCHR/L 2020	20	20	133	35	12	TCER/L / TCFR/L TQCR/L B29-B31
2525	25	25	133	28	7	
3232	32	32	153	28	-	

• Ordering example: 2 pcs. TCHR 2525

Spare parts

Designation	Clamp screw	Wrench		
TCHR/L	TS 601901	L-W4		

Perpendicular holders

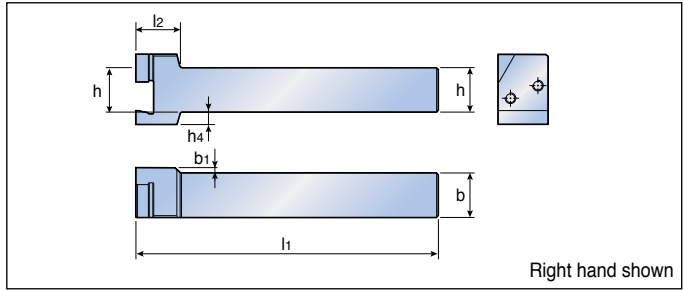

Designation	Dimension (mm)						Cartridge
	h	b	l1	l2	b1	h4	
TCHPR/L 2020	20	20	150	25	8	12	TCER/L / TCFR/L TQCR/L B29-B31
2525	25	25	150	25	3	7	
3232	32	32	170	25	-	-	

• Ordering example: 2 pcs. TCHPR 2525

Spare parts

Designation	Clamp screw	Wrench		
TCHPR/L	TS 60190I	L-W4		

C-ADAPTER

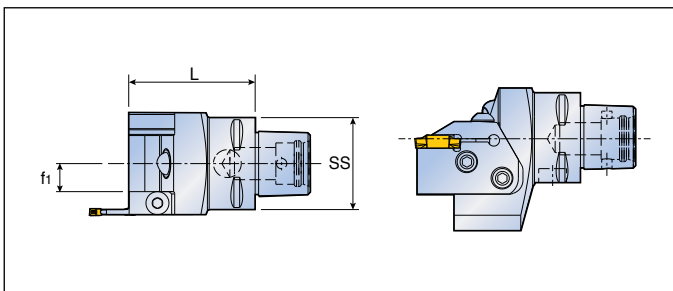

Parallel type



Designation	Dimension (mm)			Cartridge
	SS	L	f1	
C4-TCHN	40	55	12.2	TCER/L / TCFR/L
C5-TCHN	50	58	17.2	TQCR/L
C6-TCHN	63	60	22.2	 B29-B31

• Cartridge should be ordered separately

Spare parts

Designation	Screw	Nozzle	Wrench	
				
TCHN	TS 60190I	NZ-125	L-W4	

C-ADAPTER

Perpendicular type

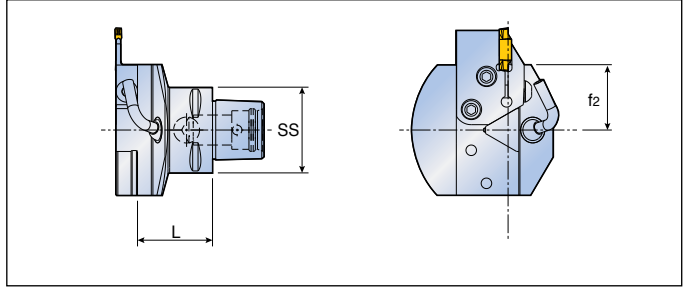

Designation	Dimension (mm)			Cartridge
	SS	L	f2	
C4-TCHPN	40	35	30.5	TCER/L / TCFR/L
C5-TCHPN	50	40	35.5	TQCR/L
C6-TCHPN	63	42	35.5	B29-B31

• Cartridge should be ordered separately

Spare parts

Designation	Screw	Nozzle	Wrench	Pipe
TCHPN	TS 60190I	NZ-125	L-W4	NZP 5

Cartridge and Holder Selection

Parallel type

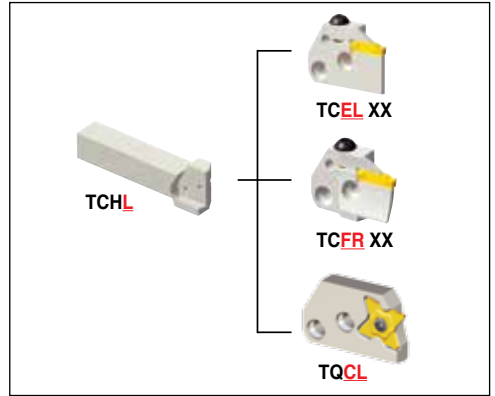
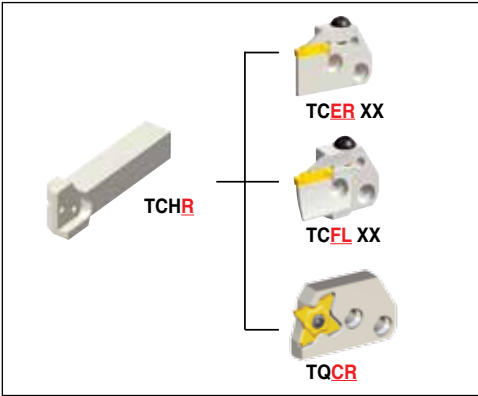

Perpendicular type

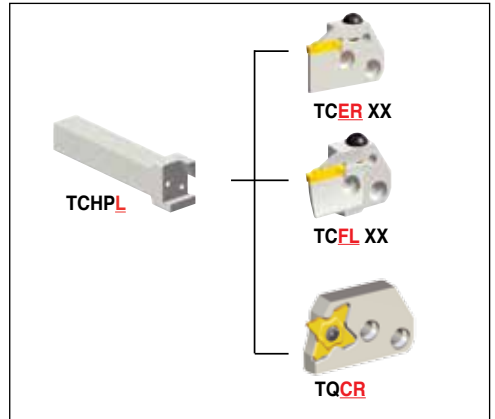
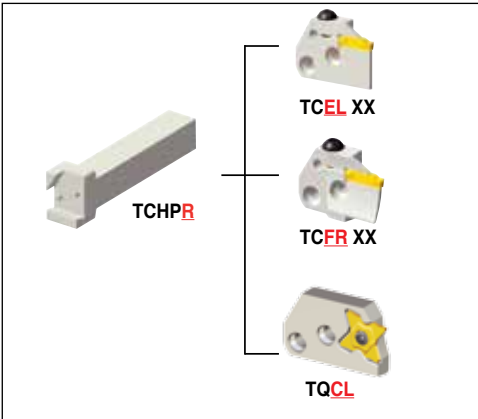

C-ADAPTER

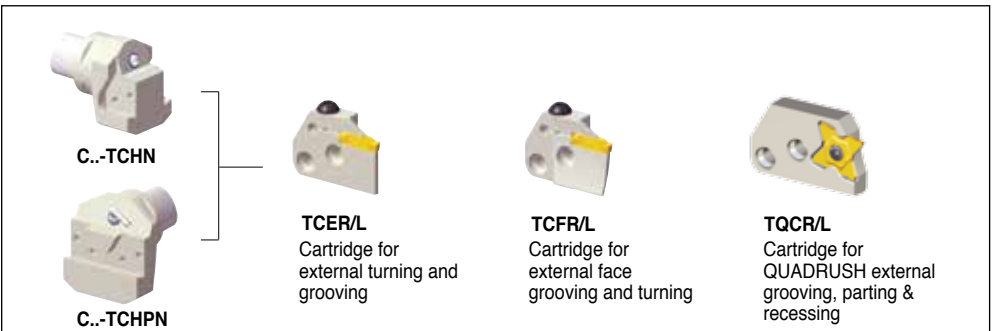

TTER/L-SH



External turning and grooving holder for swiss automatics

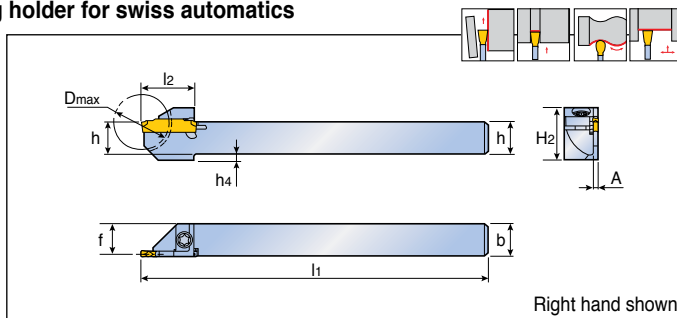

Designation	Insert seat size	Dimension (mm)									Insert
		h	b	l ₁	f	l ₂	A	h ₄	H ₂	D _{max}	
TTER/L 10-20-1.4SH	1	10	10	125	9.5	18	1.0	-	13.7	20	TDC / J / T TDXU / XT TSC / J B74-B83
12-24-1.4SH	1	12	12	125	11.5	19.5	1.0	-	15.7	24	
14-24-1.4SH	1	14	14	125	13.5	19.5	1.0	-	17.7	24	
16-32-1.4SH	1	16	16	125	15.5	24	1.0	-	19.7	32	
10-20-2SH	2	10	10	125	9.1	19	1.8	2	17.5	20	
12-24-2SH	2	12	12	125	11.1	19	1.8	2	19.0	24	
14-24-2SH	2	14	14	125	13.1	19	1.8	-	19.0	24	
16-32-2SH	2	16	16	125	15.1	24	1.8	-	21.0	32	
12-24-3SH	3	12	12	125	10.8	19	2.4	2	19.0	24	
16-32-3SH	3	16	16	125	14.8	24	2.4	-	21.0	32	

Spare parts

Designation	Screw	Wrench		
	TTER/L- SH	TS 40A115I	T15	

TTER/L-SH-TB

T-CLAMP
ULTRA PLUS

Side lock holders with channels for high pressure coolant on Swiss type automatic machines



T-BURST
HIGH PRESSURE

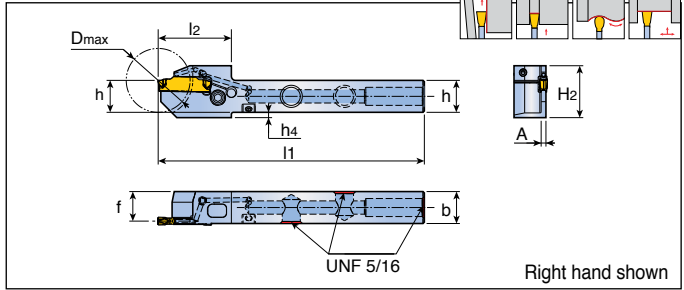

Designation	Insert seat size	Dimension (mm)									Insert
		h	b	l ₁	f	l ₂	A	h ₄	H ₂	D _{max}	
TTER/L12-24-2SH-TB	2	12	12	125	11.1	27.5	1.8	2	22.1	24	TDC / J / T / A
16-32-2SH-TB	2	16	16	125	15.1	31.5	1.8	-	24.1	32	TDXU / XT
12-24-3SH-TB	3	12	12	125	10.8	27.5	2.4	2	22.1	24	TSC / J
16-32-3SH-TB	3	16	16	125	14.8	31.5	2.4	-	24.1	32	B74-B83

	70 bar flow rate (ℓ/min)	100 bar flow rate (ℓ/min)	140 bar flow rate (ℓ/min)
TTER/L- 2SH-TB	5-7	7-9	8-10
3SH-TB	5-7	7-9	8-10

• Please refer to B69 page for T-Burst accessories

Spare parts

Designation	Clamping pin	Clamping screw	Pin plug	Wrench for clamping screw & pin plug	Inlet plug	Wrench for inlet plug
TTER/L...2SH-TB	PIN-SH-TB-L21	SS M5-24145	SS M5x3.5 ULTEM 2300	L-W 2.5F	PLG 5/16 UNF	L-W 5/32"
TTER/L...3SH-TB	PIN-SH-TB-L21	SS M5-24145	SS M5x3.5 ULTEM 2300	L-W 2.5F	PLG 5/16 UNF	L-W 5/32"

Reinforced external turning and grooving

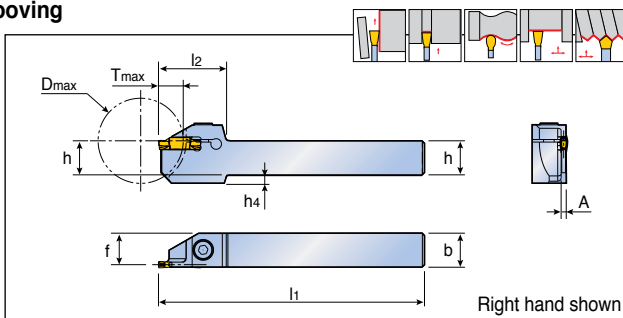

Designation	Insert seat size	Dimension (mm)									Insert
		h	b	l ₁	f	l ₂	h ₄	A	T _{max}	D _{max}	
TTER/L 1010-1.4T15-D40	1	10	10	125	9.5	32	6	1.0	15	40	TDC / J / T TDXU / XT TSC / J B74-B83
1212-1.4T15-D40	1	12	12	125	11.5	32	4	1.0	15	40	
1616-1.4T20-D45	1	16	16	125	15.5	38	4	1.0	20	45	
2020-1.4T20-D45	1	20	20	125	19.5	38	-	1.0	20	45	
1010-2T15-D40	2	10	10	125	9.1	32	6	1.8	15	40	
1212-2T15-D40	2	12	12	125	11.1	32	4	1.8	15	40	
1616-2T20-D45	2	16	16	125	15.1	38	4	1.8	20	45	
2020-2T20-D45	2	20	20	125	19.1	38	-	1.8	20	45	
2525-2T20-D45	2	25	25	150	24.1	38	-	1.8	20	45	
1212-3T15-D40	3	12	12	125	10.8	32	4	2.4	15	40	
1616-3T20-D45	3	16	16	125	14.8	38	4	2.4	20	45	
2020-3T20-D45	3	20	20	125	18.8	38	-	2.4	20	45	
2525-3T20-D45	3	25	25	150	23.8	38	-	2.4	20	45	
2525-3T25-D60	3	25	25	150	23.8	43	-	2.4	25	60	

Spare parts

Designation	Screw	Wrench		
TTER/L-D	SH M5x0.8x16	L-W 4		

Machining depth for diameter of workpiece

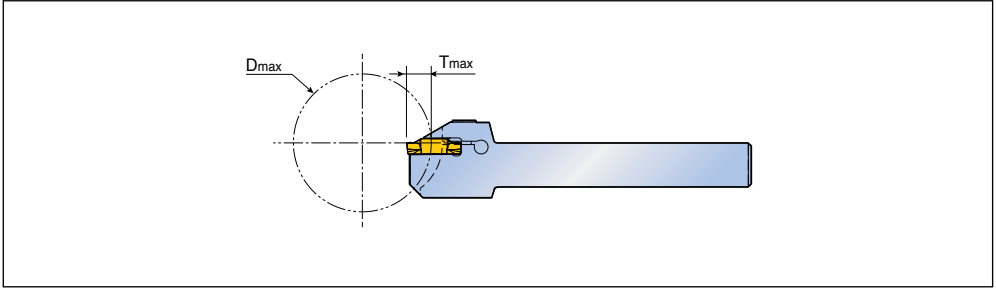

Designation		T _{max}												
		1	2	3	4	5	6	7	8	9	10	11	12	13
TTER/L 1010-1.4T15-D40	D _{max}					∞						269	120	79
1212-1.4T15-D40						∞						269	120	79
1616-1.4T20-D45						∞								432
2020-1.4T20-D45						∞								432
1010-2T15-D40						∞						269	120	79
1212-2T15-D40						∞						269	120	79
1616-2T20-D45						∞								432
2020-2T20-D45						∞								432
2525-2T20-D45						∞				1468	339	193	136	106
1212-3T15-D40						∞						269	120	79
1616-3T20-D45						∞								432
2020-3T20-D45						∞								432
2525-3T20-D45						∞				1468	339	193	136	106
2525-3T25-D60						∞								

Designation		T _{max}														
		14	15	16	17	18	19	20	21	22	23	24	25			
TTER/L 1010-1.4T15-D40	D _{max}	59	40													
1212-1.4T15-D40		59	40													
1616-1.4T20-D45		193	125	94	76	64	57	45								
2020-1.4T20-D45		193	125	94	76	64	57	45								
1010-2T15-D40		59	40													
1212-2T15-D40		59	40													
1616-2T20-D45		193	125	94	76	64	57	45								
2020-2T20-D45		193	125	94	76	64	57	45								
2525-2T20-D45		87	75	67	60	56	52	45								
1212-3T15-D40		59	40													
1616-3T20-D45		193	125	94	76	64	57	45								
2020-3T20-D45		193	125	94	76	64	57	45								
2525-3T20-D45		87	75	67	60	56	52	45								
2525-3T25-D60					1810	418	237	167	130	107	91	81	73	60		

External turning and grooving

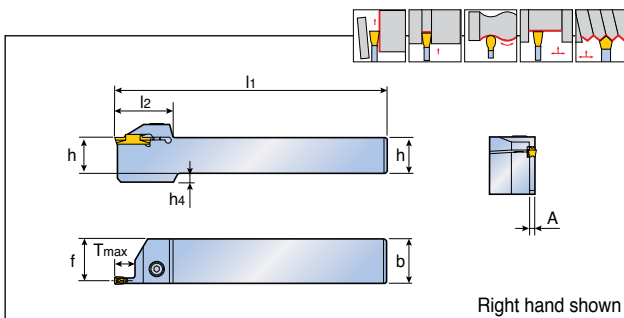
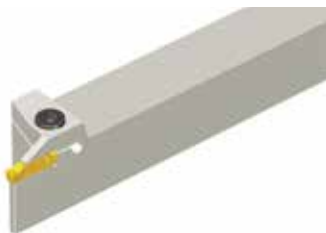

Designation	Insert seat size	Dimension (mm)								Insert
		h	b	l ₁	f	l ₂	A	h ₄	T _{max}	
TTER/L 1616-2T08	2	16	16	110	15.1	33.0	1.8	4	8	TDC / J / T / A
2020-2T08	2	20	20	125	19.1	33.0	1.8	-	8	TDXU / XT
2525-2T08	2	25	25	150	24.1	33.0	1.8	-	8	TSC / J / A
1616-2	2	16	16	110	15.1	32.0	1.8	4	12	B74-B87
2020-2	2	20	20	125	19.1	32.0	1.8	-	12	
2525-2	2	25	25	150	24.1	32.0	1.8	-	12	
1616-2T17	2	16	16	110	15.1	37.0	1.8	4	17	
2020-2T17	2	20	20	125	19.1	37.0	1.8	-	17	
2525-2T17	2	25	25	150	24.1	37.0	1.8	-	17	
TTER/L 1616-3T09	3	16	16	110	14.8	32.0	2.4	4	9	
2020-3T09	3	20	20	125	18.8	32.0	2.4	-	9	
2525-3T09	3	25	25	150	23.8	32.0	2.4	-	9	
1616-3	3	16	16	110	14.8	32.0	2.4	4	12	
2020-3	3	20	20	125	18.8	32.0	2.4	-	12	
2525-3	3	25	25	150	23.8	32.0	2.4	-	12	
1616-3T20	3	16	16	110	14.8	38.5	2.4	-	20	
2020-3T20	3	20	20	125	18.8	38.5	2.4	-	20	
2525-3T20	3	25	25	150	23.8	38.5	2.4	-	20	
2525-3T25	3	25	25	150	23.8	44.5	2.4	-	25	
3232-3T20	3	32	32	170	30.8	38.5	2.4	-	20	
TTER/L 1616-4T10	4	16	16	110	14.5	32.0	3.0	4	10	
2020-4T10	4	20	20	125	18.5	32.0	3.0	-	10	
2525-4T10	4	25	25	150	23.5	32.0	3.0	-	10	
1616-4	4	16	16	110	14.5	33.0	3.0	4	15	
2020-4	4	20	20	125	18.5	33.0	3.0	-	15	
2525-4	4	25	25	150	23.5	33.0	3.0	-	15	
1616-4T25	4	16	16	110	14.5	45.0	3.0	-	25	
2020-4T25	4	20	20	125	18.5	45.0	3.0	-	25	
2525-4T25	4	25	25	150	23.5	45.0	3.0	-	25	
3232-4T25	4	32	32	170	30.5	45.0	3.0	-	25	
TTER/L 2020-5T12	5	20	20	125	18.1	37.0	4.0	-	12	
2525-5T12	5	25	25	150	23.1	37.0	4.0	-	12	
2020-5	5	20	20	125	18.1	37.0	4.0	-	20	
2525-5	5	25	25	150	23.1	37.0	4.0	-	20	
2525-5T32	5	25	25	150	23.0	56.0	4.0	-	32	
3232-5T20	5	32	32	170	30.0	39.0	4.0	-	20	
3232-5T32	5	32	32	170	30.0	56.0	4.0	-	32	

External turning and grooving

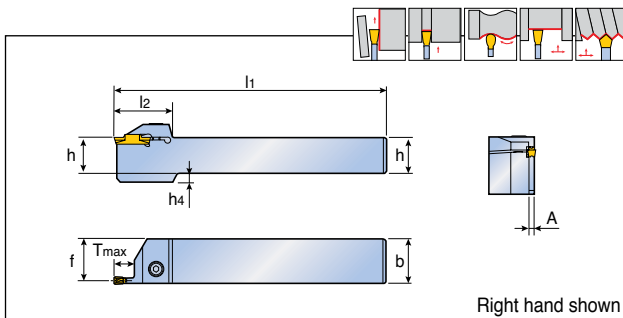

Designation	Insert seat size	Dimension (mm)								Insert
		h	b	l ₁	f	l ₂	A	h ₄	T _{max}	
TTER/L 2020-6T12	6	20	20	125	17.6	37	5.0	-	12	TDC / J / T / A
2525-6T12	6	25	25	150	22.6	37	5.0	7	12	TDXU / XT
2020-6	6	20	20	125	17.6	41	5.0	-	20	TSC / J / A
2525-6	6	25	25	150	22.6	41	5.0	7	20	B74-B87
2525-6T32	6	25	25	150	22.5	56	5.0	7	32	
3232-6T20	6	32	32	170	29.5	41	5.0	-	20	
3232-6T25	6	32	32	170	29.5	46	5.0	-	25	
3232-6T32	6	32	32	170	29.5	56	5.0	-	32	
TTER/L 2525-8T16	8	25	25	150	22.1	47	6.0	7	16	
2525-8	8	25	25	150	22.1	47	6.0	7	25	
3232-8	8	32	32	170	29.1	47	6.0	-	25	
2525-8T36	8	25	25	150	22.1	60	6.0	7	36	
3232-8T36	8	32	32	170	29.1	60	6.0	-	36	
TTER/L 2525-10T25	10	25	25	150	21.1	50	7.85	7	25	
3232-10T25	10	32	32	170	28.1	50	7.85	-	25	
4040-10T25	10	40	40	200	36.1	50	7.85	-	25	

Spare parts

Designation	Screw	Wrench		
TTER/L 1616-2/3	SH M5x0.8x16	L-W 4		
TTER/L 2020-2/3	SH M5x0.8x20	L-W 4		
TTER/L 2525-2/3	SH M5x0.8x25	L-W 4		
TTER/L 3232-3	SH M5x0.8x25	L-W 4		
TTER/L 1616-4/5	SH M6x1x16	L-W 5		
TTER/L 2020-4/5	SH M6x1x20	L-W 5		
TTER/L 2525-4/5	SH M6x1x25	L-W 5		
TTER/L 3232-4/5	SH M6x1x25	L-W 5		
TTER/L 2020-6	SH M8x1.25x20	L-W 6		
TTER/L 2525-6/8	SH M8x1.25x25	L-W 6		
TTER/L 3232-6/8/10	SH M8x1.25x25	L-W 6		
TTER/L 4040-10	SH M8x1.25x25	L-W 6		

Grooving and turning with channels for high pressure coolant



T-BURST
HIGH PRESSURE

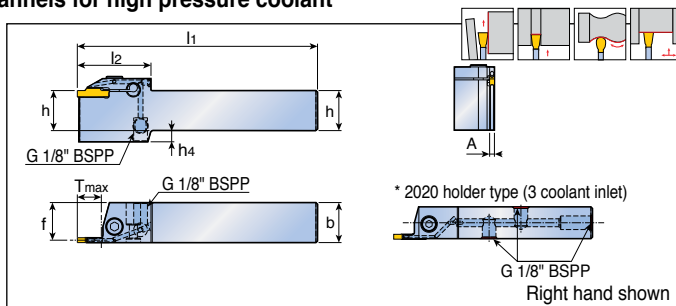

Designation	Insert seat size	Dimension (mm)								Insert
		h	b	l ₁	f	l ₂	A	h ₄	T _{max}	
TTER/L 2020-2T12-TB	2	20	20	125	19.1	43	1.8	-	12	TDC / J / T / A TDXU / XT TSC / J / A B74-B87
2525-2T12-TB	2	25	25	150	24.1	43	1.8	-	12	
2020-3-TB	3	20	20	125	18.8	43	2.4	-	12	
2020-4-TB	4	20	20	125	18.5	46	3.0	-	15	
2525-3-TB	3	25	25	150	23.8	43	2.4	-	12	
2525-4-TB	4	25	25	150	23.5	46	3.0	-	15	
2525-5-TB	5	25	25	150	23.1	49	4.0	-	20	
2525-6-TB	6	25	25	150	22.6	52	5.0	7	20	
2525-8-TB	8	25	25	150	22.1	58	6.0	7	25	

	70 bar flow rate (ℓ/min)	100 bar flow rate (ℓ/min)	140 bar flow rate (ℓ/min)
TTER/L 2020-2T12-TB	5-7	7-9	8-10
2525-2T12-TB	5-7	7-9	8-10
2020-3-TB	5-7	7-9	9-11
2020-4-TB	6-8	10-12	12-14
2525-3-TB	6-8	8-10	10-12
2525-4-TB	10-12	14-16	16-18
2525-5-TB	13-16	19-21	22-24
2525-6-TB	13-16	19-21	22-24
2525-8-TB	13-16	19-21	22-24

• Please refer to B69 page for T-Burst accessories

Spare parts

Designation	Screw	Wrench	Plug	Wrench for plug
TTER/L 2020-2T12-TB	SH M5x0.8x20	L-W4	PLG G1/8-L6.5	L-W5
TTER/L 2525-2T12-TB	SH M5x0.8x20	L-W4	PLG G1/8-T8.0-L12.3	L-W5
TTER/L 2020-3-TB	SH M5x0.8x20	L-W4	PLG G1/8-L6.5	L-W5
TTER/L 2020-4-TB	SH M6x1.0x20	L-W5	PLG G1/8-L6.5	L-W5
TTER/L 2525-3-TB	SH M5x0.8x20	L-W4	PLG G1/8-T8.0-L12.3	L-W5
TTER/L 2525-4 / 5-TB	SH M6x1.0x20	L-W5	PLG G1/8-T8.0-L12.3	L-W5
TTER/L 2525-6 / 7-TB	SH M8x1.25x20	L-W6	PLG G1/8-T8.0-L12.3	L-W5

External turning and grooving

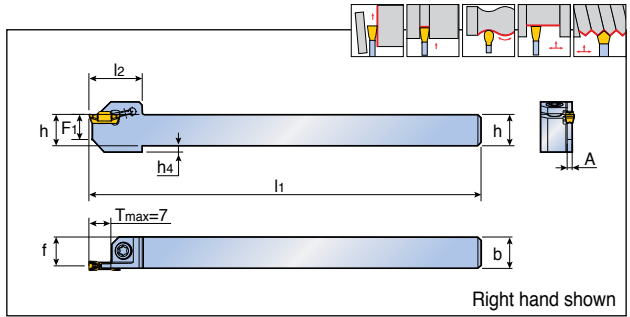

Designation	Insert seat size	Dimension (mm)								Insert
		h	b	l ₁	f	F ₁	l ₂	A	h ₄	
TTSER/L 1010-2T7	2	10	10	125	9.2	8	17	1.6	2	TDIM / IP B85-B86
1212-2T7	2	12	12	125	11.2	8	17	1.6	-	
1616-2T7	2	16	16	125	15.2	11	20	1.6	-	
2020-2T7	2	20	20	125	19.2	14	20	1.6	-	
2525-2T7	2	25	25	125	24.2	18	20	1.6	-	
1010-3T7	3	10	10	125	8.8	8	17	2.4	2	
1212-3T7	3	12	12	125	10.8	8	17	2.4	-	
1616-3T7	3	16	16	125	14.8	11	20	2.4	-	
2020-3T7	3	20	20	125	18.8	14	20	2.4	-	
2525-3T7	3	25	25	125	23.8	18	20	2.4	-	

Spare parts

Designation	Screw	Wrench		
TTSER/L	TS 400971	T 15		

Shallow turning and grooving

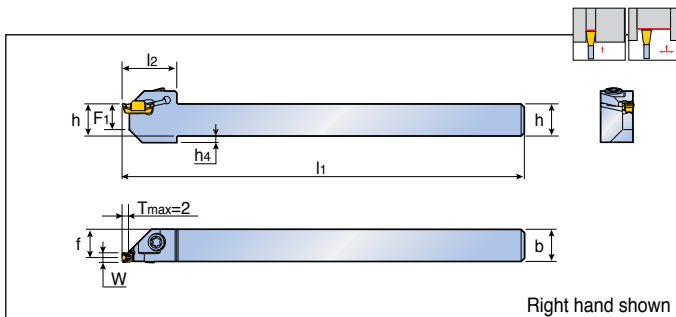

Designation	Insert seat size	Dimension (mm)								Insert
		h	b	l ₁	f	F ₁	l ₂	h ₄	W	
TGSFR/L 1010-3T2	2, 3	10	10	125	8.8	8	17	2	≤ 3	TDIM / IP B85-B86
1212-3T2	2, 3	12	12	125	10.8	8	17	-	≤ 3	
1616-3T2	2, 3	16	16	125	14.8	11	20	-	≤ 3	

Spare parts

Designation	Screw	Wrench		
TGSFR/L	TS 400971	T 15		

External face grooving and turning

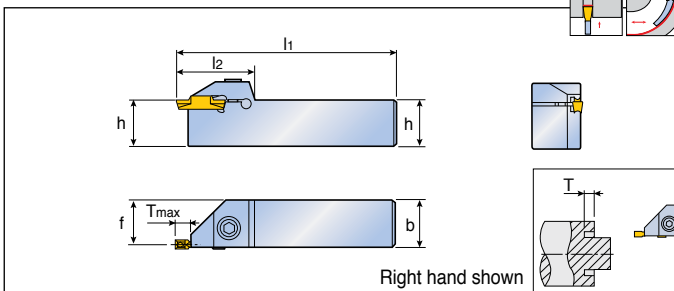

Designation	Insert seat size	Dimension (mm)						Insert
		h	b	l ₁	f	l ₂	T _{max}	
TGFR/L 1616-4	2, 3, 4	16	16	110	14.5	33	4.8	TDC ⁽¹⁾ / J ⁽¹⁾ / T
2020-4	2, 3, 4	20	20	125	18.5	33	4.8	TDXU / XT / FT
2525-4	2, 3, 4	25	25	150	23.5	33	4.8	TSC ⁽¹⁾ / J ⁽¹⁾
2020-6	5, 6	20	20	125	17.6	37	4.8	B74-B83
2525-6	5, 6	25	25	150	22.6	37	4.8	

- ⁽¹⁾ Insert for grooving only
- External turning & grooving is available depending on the insert type
- Please check insert min. dia for face grooving [B49](#) page

Spare parts

Designation	Screw	Wrench		
TGFR/L 1616	SH M6x1x16	L-W5		
TGFR/L 2020	SH M6x1x20	L-W5		
TGFR/L 2525	SH M6x1x25	L-W5		

Deep face grooving and turning

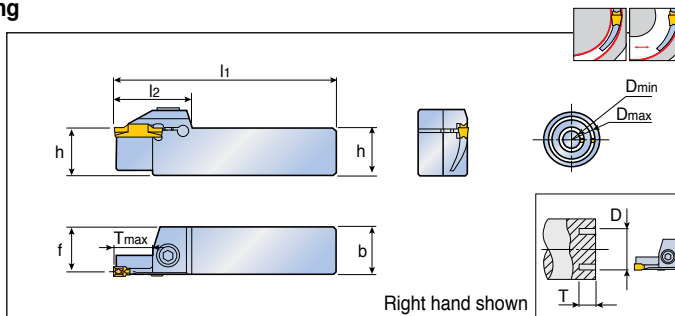

Designation	Insert seat size	Dimension (mm)									Insert
		h	b	l ₁	f	l ₂	T _{max}	D _{min}	D _{max}		
TTFR/L 25-30-3	3	25	25	150	24.0	32	10	24	35	TDC ⁽¹⁾ / J ⁽¹⁾ / T TDXU / XT / FT TSC ⁽¹⁾ / J ⁽¹⁾ B74-E83	
25-35-3	3	25	25	150	24.0	32	10	29	40		
25-40-3	3	25	25	150	24.0	32	10	34	50		
25-50-3	3	25	25	150	24.0	32	15	44	60		
25-60-3	3	25	25	150	24.0	32	15	54	85		
25-30-4	4	25	25	150	23.6	33	12	22	40		
25-40-4	4	25	25	150	23.6	33	15	32	50		
25-50-4	4	25	25	150	23.6	33	15	42	60		
25-60-4	4	25	25	150	23.6	33	15	52	85		
25-60-5	5	25	25	150	23.5	41	20	50	80		
25-80-5	5	25	25	150	23.5	41	20	70	110		
25-110-5	5	25	25	150	23.5	41	20	110	150		
25-150-5	5	25	25	150	23.5	41	20	140	200		
25-60-6	6	25	25	150	22.6	41	20	48	85		
25-85-6	6	25	25	150	22.6	41	20	73	150		
25-150-6	6	25	25	150	22.6	41	20	138	250		
25-250-6	6	25	25	150	22.6	41	20	250	∞		

- ⁽¹⁾ Insert for grooving only
- Please check insert min. dia for face grooving B49 page

Spare parts

Designation	Screw	Wrench		
TTFR/L...-3	SH M5x0.8x25	L-W 4		
TTFR/L...-4	SH M6x1x25	L-W 5		
TTFR/L...-5	SH M8X1.25X25	L-W 5		
TTFR/L...-6	SH M8X1.25X25	L-W 5		

TTFR/L-RN (Renewed Type)

Deep face grooving and turning

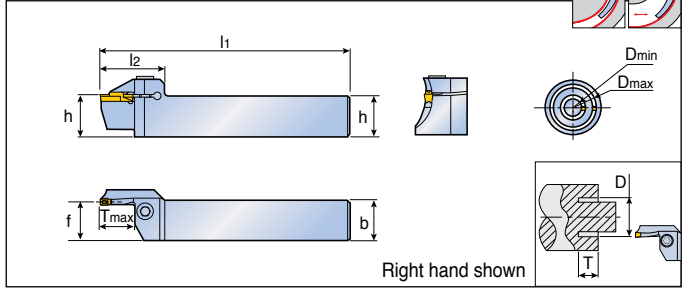

Designation	Insert seat size	Dimension (mm)								Insert
		h	b	l ₁	f	l ₂	T _{max}	D _{min}	D _{max}	
TTFR/L 20-21-30-3T10 RN	3	20	20	140	19.0	31	10	21	30	TDC ⁽¹⁾ / J ⁽¹⁾ / T TDXU / XT / FT TSC ⁽¹⁾ / J ⁽¹⁾ B74-B83
20-24-35-3T10 RN	3	20	20	140	19.0	31	10	24	35	
20-29-40-3T10 RN	3	20	20	140	19.0	31	10	29	40	
20-34-50-3T10 RN	3	20	20	140	19.0	31	10	34	50	
20-44-70-3T15 RN	3	20	20	140	19.0	35	15	44	70	
20-64-100-3T15 RN	3	20	20	140	19.0	35	15	64	100	
25-30-3 RN	3	25	25	150	24.0	38	10	24	35	
25-35-3 RN	3	25	25	150	24.0	38	10	29	40	
25-40-3 RN	3	25	25	150	24.0	38	10	34	50	
25-50-3 RN	3	25	25	150	24.0	38	15	44	70	
25-70-3 RN	3	25	25	150	24.0	38	15	64	100	
20-19-30-4T10 RN	4	20	20	140	18.6	31	10	19	30	
20-22-36-4T10 RN	4	20	20	140	18.6	31	10	22	36	
20-28-42-4T16 RN	4	20	20	140	18.6	36	16	28	42	
20-34-50-4T16 RN	4	20	20	140	18.6	36	16	34	50	
20-42-70-4T16 RN	4	20	20	140	18.6	36	16	42	70	
20-62-120-4T16 RN	4	20	20	140	18.6	36	16	62	120	
20-112-200-4T16 RN	4	20	20	140	18.6	36	16	112	200	
25-30-4 RN	4	25	25	150	23.6	39	10	22	36	
25-36-4 RN	4	25	25	150	23.6	39	20	28	42	
25-42-4 RN	4	25	25	150	23.6	39	20	34	50	
25-50-4 RN	4	25	25	150	23.6	39	20	42	70	
25-70-4 RN	4	25	25	150	23.6	39	20	62	120	
25-120-4 RN	4	25	25	150	23.6	39	20	112	200	
25-200-4 RN	4	25	25	150	23.6	39	20	200	∞	
25-60-5T15 RN	5	25	25	150	23.1	41	15	50	80	
25-60-5 RN	5	25	25	150	23.1	49	25	50	80	
25-80-5T15 RN	5	25	25	150	23.1	41	15	70	110	
25-80-5 RN	5	25	25	150	23.1	49	25	70	110	
25-110-5 RN	5	25	25	150	23.1	49	25	100	150	
25-150-5 RN	5	25	25	150	23.1	49	25	140	200	
25-200-5 RN	5	25	25	150	23.1	49	25	200	∞	

- ⁽¹⁾ Insert for grooving only
- Please check insert min. dia for face grooving B49 page

TTFR/L-RN (Renewed Type)

Deep face grooving and turning

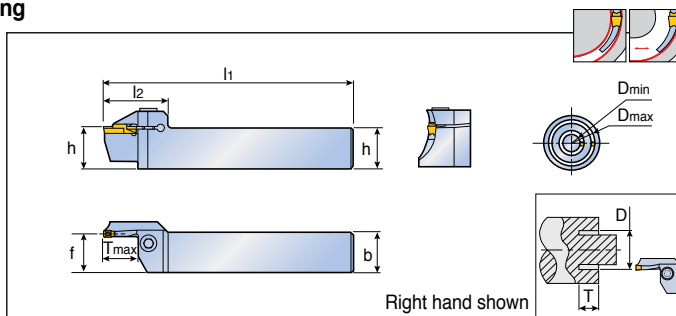

Designation	Insert seat size	Dimension (mm)								Insert
		h	b	l ₁	f	l ₂	T _{max}	D _{min}	D _{max}	
TTFR/L 25-60-6 RN	6	25	25	150	22.6	49	25	48	70	TDC ⁽¹⁾ / J ⁽¹⁾ / T TDXU / XT / FT TSC ⁽¹⁾ / J ⁽¹⁾ B74-B83
25-70-6 RN	6	25	25	150	22.6	49	25	58	100	
25-100-6 RN	6	25	25	150	22.6	49	25	88	180	
25-180-6 RN	6	25	25	150	22.6	49	25	168	400	
25-400-6 RN	6	25	25	150	22.6	49	25	400	∞	

- ⁽¹⁾ Insert for grooving only
- Please check insert min. dia for face grooving B49 page

Insert initial min.Dia (Dmin) for face grooving

Machining	Insert	Size (mm)	Min. dia. (mm)	Insert	Size (mm)	Min. dia. (mm)
Facing Min. dia. of face machining	TDJ/C	3	54	TDT RU	3	41
		4	34		4	36
		5	49		5	54
		6	46		6	54
	TDT	3	44	TDXU	3	18
		4	42		4	18
		5	50		5	20
		6	48		6	18

Spare parts

Designation	Screw	Wrench		
	TTFR/L 20...RN	SH M6x1x20	L-W 5	
TTFR/L 25...3/4 RN	SH M6x1x25	L-W 5		
TTFR/L 25...5/6 RN	SH M8x1.25x25	L-W 6		

Shallow face perpendicular grooving and face turning

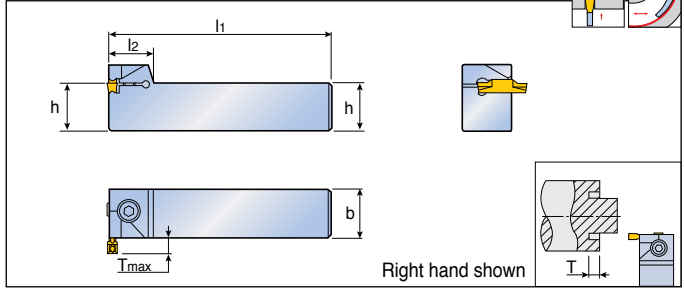
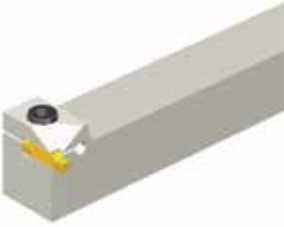

Designation	Insert seat size	Dimension (mm)					Insert
		h	b	l ₁	l ₂	T _{max}	
TGFPR/L 2020-4	2, 3, 4	20	20	125	18	4.8	TDC ⁽¹⁾ / J ⁽¹⁾ / T
2525-4	2, 3, 4	25	25	150	18	4.8	TDXU / XT / FT
2525-6	5, 6	25	25	150	22	4.8	TSC ⁽¹⁾ / J ⁽¹⁾
							B74-E83

- ⁽¹⁾ Insert for grooving only
- External Turning & Grooving is available depending on the insert
- Please check insert min. dia for face grooving B49 page

Spare parts

Designation	Screw	Wrench		
TGFPR/L 2020	SH M6x1x20	L-W5		
TGFPR/L 2525	SH M6x1x25	L-W5		
TGFPR/L 2525	SH M6x1x25	L-W5		

Deep face grooving and turning

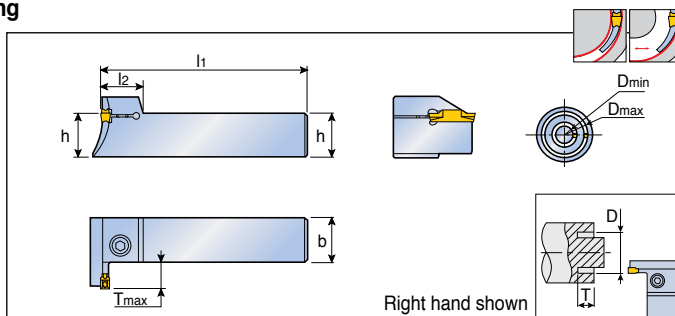

Designation	Insert seat size	Dimension (mm)							Insert
		h	b	l1	l2	Tmax	Dmin	Dmax	
TTFPR/L 25-30-3	3	25	25	150	18.0	10	24	35	TDC ⁽¹⁾ / J ⁽¹⁾ / T
25-35-3	3	25	25	150	18.0	10	29	40	TDXU / XT / FT
25-40-3	3	25	25	150	18.0	10	34	50	TSC ⁽¹⁾ / J ⁽¹⁾
25-50-3	3	25	25	150	18.0	15	44	60	B74-B83
25-60-3	3	25	25	150	18.0	15	54	85	
25-30-4	4	25	25	150	18.5	12	22	40	
25-40-4	4	25	25	150	18.5	15	32	50	
25-50-4	4	25	25	150	18.5	15	42	60	
25-60-4	4	25	25	150	18.5	15	52	85	
25-60-5	5	25	25	150	22.0	20	50	80	
25-80-5	5	25	25	150	22.0	20	70	110	
25-110-5	5	25	25	150	22.0	20	100	150	
25-150-5	5	25	25	150	22.0	20	140	200	
25-200-5	5	25	25	150	22.0	20	200	∞	
25-60-6	6	25	25	150	22.0	20	48	85	
25-85-6	6	25	25	150	22.0	20	73	150	
25-150-6	6	25	25	150	22.0	20	138	250	
25-250-6	6	25	25	150	22.0	20	250	∞	

- ⁽¹⁾ Insert for grooving only
- Please check insert min. dia for face grooving B49 page

Spare parts

Designation	Screw	Wrench		
TTFPR/L...-3	SH M5x0.8x25	L-W 4		
TTFPR/L...-4	SH M6x1x25	L-W 5		
TTFPR/L...-5	SH M8x1.25x25	L-W 6		
TTFPR/L...-6	SH M8x1.25x25	L-W 6		

Shallow internal face grooving and face turning

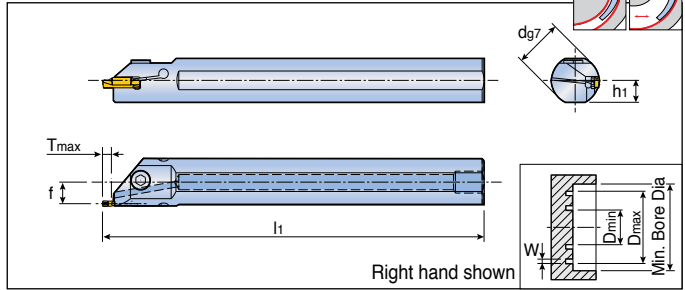

Designation	Insert seat size	Dimension (mm)					Insert
		d	l ₁	f	h ₁	T _{max}	
TGIFR/L 25-4C-T5.5	3, 4	25	200	11.3	11.5	5.5	TDC ⁽¹⁾ / J ⁽¹⁾ / T
32-4C-T5.5	3, 4	32	250	14.8	15.0	5.5	TDXU / XT / FT
25-6C-T5.5	5, 6	25	200	10.3	11.5	5.5	TSC ⁽¹⁾ / J ⁽¹⁾
32-6C-T5.5	5, 6	32	250	13.8	15.0	5.5	B74-B83

- ⁽¹⁾ Insert for grooving only
- Please check insert min. dia for face grooving B49 page

W	Min. bore dia		Dmin				Dmax
	d=25	d=32	TDC / TDJ	TDFT / TD XU / TDXT	TDT	TDT-RU	
3	26.3	33.3	54	18	44	41	∞
4	26.8	33.8	34	18	42	36	
5	26.3	33.3	49	20	50	54	
6	26.8	33.8	46	18	48	54	

TGIFR/L Application

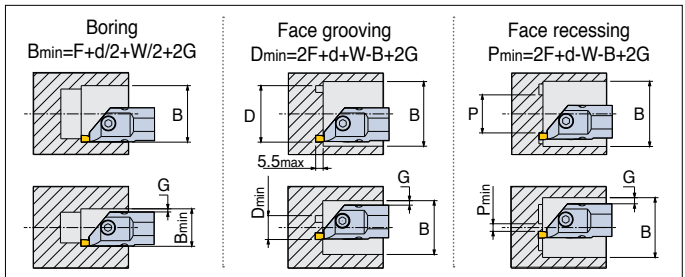

Spare parts

Designation	Screw	Wrench	Seal	
TGIFR/L 25	SH M6x1x16	L-W5	PL 25 (R1/8")	
TGIFR/L 32	SH M6x1x16	L-W5	PL 32 (R1/8")	

Internal face grooving and face turning

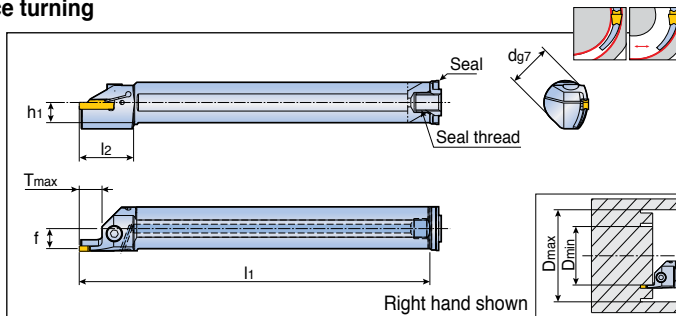

Designation	Insert seat size	Dimension (mm)								Insert
		d	l ₁	l ₂	f	h ₁	T _{max}	D _{min}	D _{max}	
TTFIR/L 25-3T12 20-33	3	25	200	31	11.5	11.5	12	20	33	TDC ⁽¹⁾ / J ⁽¹⁾ / T
25-3T12 26-39	3	25	200	31	11.5	11.5	12	26	39	TDXU / XT / FT
25-3T12 33-48	3	25	200	31	11.5	11.5	12	33	48	TSC ⁽¹⁾ / J ⁽¹⁾
25-3T12 42-60	3	25	200	31	11.5	11.5	12	42	60	B74-B83
25-3T12 54-85	3	25	200	31	11.5	11.5	12	54	85	
25-3T12 79-150	3	25	200	31	11.5	11.5	12	79	150	
25-4T12 18-34	4	25	200	31	11.0	11.5	12	18	34	
25-4T12 26-42	4	25	200	31	11.0	11.5	12	26	42	
25-4T12 34-55	4	25	200	31	11.0	11.5	12	34	55	
32-4T12 47-70	4	32	250	31	14.5	15.0	12	47	70	
32-4T12 62-100	4	32	250	31	14.5	15.0	12	62	100	
32-4T12 92-180	4	32	250	31	14.5	15.0	12	92	180	

- ⁽¹⁾ Insert for grooving only
- Please check insert min. dia for face grooving [B49](#) page

Spare parts

Designation	Screw	Wrench	Seal	
TTFIR/L 25	SH M5x0.8x16	L-W 4	PL 25 (R1/8")	
TTFIR/L 32	SH M5x0.8x16	L-W 4	PL 32 (R1/8")	

Internal turning, grooving and profiling

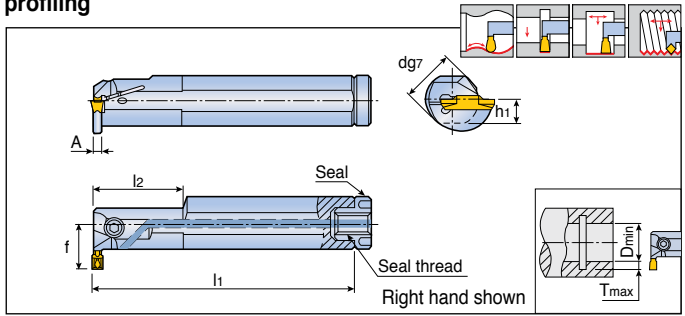

Designation	Insert seat size	Dimension (mm)								Insert
		d	l ₁	l ₂	f	h ₁	A	T _{max}	D _{min}	
TTIR/L 16-2C	2	16	125	-	16.5	7.5	1.8	8.5	25	TDC ⁽¹⁾ / J ⁽¹⁾ / T
20-2C	2	20	160	40	15.8	9.0	1.6	6.0	25	TDXU / XT / FT / IT
25-2C	2	25	200	40	17.5	11.5	1.6	5.0	25	TSC ⁽¹⁾ / J ⁽¹⁾
32-2C-T8	2	32	250	40	24.8	14.0	1.8	8.0	36	B74-B84
20-3C	3	20	160	40	15.8	9.0	2.1	6.0	25	
25-3C	3	25	200	40	17.5	11.5	2.1	5.1	25	
25-3C-T8	3	25	200	40	21.5	11.5	2.4	8	32	
32-3C	3	32	250	60	20.8	14.0	2.1	4.7	31	
32-3C-T10	3	32	250	60	27.0	15.0	2.4	10	40	
40-3C-T12	3	40	300	65	33.0	19.0	2.4	12	50	
20-4C	4	20	160	40	15.8	9.0	2.9	6.0	25	
25-4C	4	25	200	40	17.5	11.5	2.9	5.2	25	
25-4C-T8	4	25	200	40	21.5	11.5	3.0	8	32	
32-4C	4	32	250	60	20.8	14.0	2.9	4.7	31	
32-4C-T10	4	32	250	60	27.0	15.0	3.0	10	40	
40-4C-T12	4	40	300	65	33.0	19.0	3.0	12	50	
50-4C-T14	4	50	350	70	40.0	23.5	3.0	14	60	
25-5C	5	25	200	40	17.3	11.5	3.9	5.2	31	
32-5C	5	32	250	60	20.8	14.0	3.9	4.7	31	
32-5C-T10	5	32	250	60	27.0	15.0	3.85	10	40	
40-5C-T12	5	40	300	65	33.0	19.0	3.85	12	50	
50-5C-T14	5	50	350	70	40.0	23.5	3.85	14	60	
32-6C	6	32	250	60	20.8	14.0	4.9	4.7	31	
32-6C-T10	6	32	250	60	27.0	15.0	4.85	10	40	
40-6C-T12	6	40	300	65	33.0	19.0	4.85	12	50	
50-6C-T14	6	50	350	70	40.0	23.5	4.85	14	60	
32-8C	8	32	250	60	21.3	14.5	5.9	5.5	37	
40-8C	8	40	300	65	25.8	19.0	5.9	5.8	42	

• ⁽¹⁾ Insert for grooving only
 • Please check insert min. dia for internal grooving B55 page

Internal turning, grooving and profiling

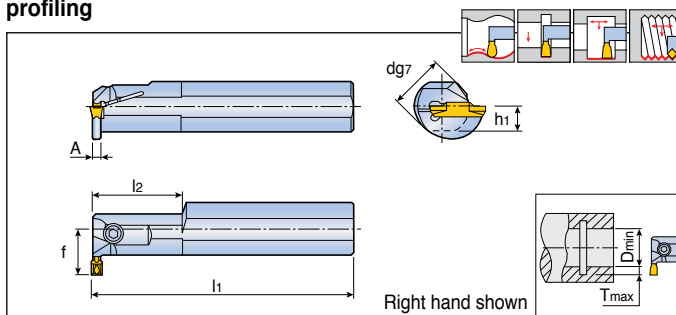

Designation	Insert seat size	Dimension (mm)								Insert
		d	l ₁	l ₂	f	h ₁	A	T _{max}	D _{min}	
TTIR/L 16-2	2	16	125	-	16.5	7.5	1.8	8.5	25	TDC ⁽¹⁾ / J ⁽¹⁾ / T
20-2	2	20	160	40	15.8	9.0	1.6	6.0	25	TDXU / XT /
25-2	2	25	200	40	17.5	11.5	1.6	5.0	25	FT / IT
32-2	2	32	250	60	20.8	14.0	1.5	4.7	31	TSC ⁽¹⁾ / J ⁽¹⁾
20-3	3	20	160	40	15.8	9.0	2.1	6.0	25	 B74-B84
25-3	3	25	200	40	17.5	11.5	2.1	5.1	25	
32-3	3	32	250	60	20.8	14.0	2.1	4.7	31	
20-4	4	20	160	40	15.8	9.0	2.9	6.0	25	
25-4	4	25	200	40	17.5	11.5	2.9	5.2	25	
32-4	4	32	250	60	20.8	14.0	2.9	4.7	31	

- ⁽¹⁾ Insert for grooving only
- Without "C" on the description: non-coolant hole type
- Please check insert min. dia for internal grooving [B55](#) page

Machining	TDJ/C		TDT		TDT RU		TDXU	
	Size (mm)	Min. dia. (mm)	Size (mm)	Min. dia. (mm)	Size (mm)	Min. dia. (mm)	Size (mm)	Min. dia. (mm)
Internal grooving Min. dia. of internal machining 	2	40	3	40	2	41	2	24
	3	50	4	40	3	38	3	24
	4	50	5	50	4	38	4	21
	5	60	6	50	5	43	5	30
	6	60	8	62	6	46	6	31
	8	70			8	56	8	33

Spare parts

Designation	Screw	Wrench	Seal *
TTIR/L 16-2	SH M5x0.8x10	L-W 4	PL 16 (M6)
TTIR/L 20-2/3/4	SH M5x0.8x12	L-W 4	PL 20 (M6)
TTIR/L 25-2/3/4	SH M5x0.8x16	L-W 4	PL 25 (R1/8")
TTIR/L 32-2/3/4	SH M5x0.8x16	L-W 4	PL 32 (R1/8")
TTIR/L 40-3/4	SH M5x0.8x16	L-W 4	PL 40 (R1/8")
TTIR/L 50-4	SH M5x0.8x20	L-W 4	PL 40 (R1/8")
TTIR/L 25-5/6	SH M6x1x16	L-W 5	PL 25 (R1/8")
TTIR/L 32-5/6	SH M6x1x20	L-W 5	PL 32 (R1/8")
TTIR/L 40/50-5/6	SH M6x1x25	L-W 5	PL 40 (R1/8")

* For through coolant type only

Internal, grooving and turning on small diameter

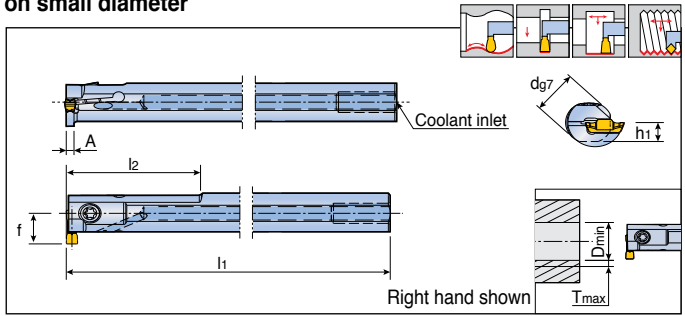

Designation	Insert seat size	Dimension (mm)								Coolant inlet	Insert
		d	l ₁	l ₂	f	h ₁	A	T _{max}	D _{min}		
TTSIR/L 10-12.5-2	2	10	125	25	7.5	4.5	1.6	2.4	12.5	Ø3.5	TDIM / TDIP
12-14-2	2	12	125	35	9.1	5.5	1.6	2.6	14.0	Ø6	B85-B86
16-12.5-2	2	16	150	20	10.5	7.5	1.6	2.4	12.5	-	
16-14-2	2	16	150	25	11.0	7.5	1.6	2.6	14.0	-	
16-16-2	2	16	150	40	11.0	7.5	1.6	3.0	16.0	-	
12-14-3	3	12	125	35	9.1	5.5	2.0	2.6	14.0	Ø6	
16-12.5-3	3	16	150	20	10.5	7.5	2.0	2.4	12.5	-	
16-14-3	3	16	150	25	11.0	7.5	2.0	2.6	14.0	-	
16-16-3	3	16	150	40	11.0	7.5	2.0	3.0	16.0	-	
20-20-3	3	20	150	40	14.0	9.0	2.0	4.0	20.0	-	

Spare parts

Designation	Screw	Wrench	Seal	
TTSIR/L 10/12	TS 400931	T 15	-	
TTSIR/L 16-12/14	TS 400931	T 15	PL 16 (M6)	
TTSIR/L 16-16	TS 501251	T 20	PL 16 (M6)	
TTSIR/L 20	TS 501251	T 20	PL 20 (M6)	

Internal shallow grooving and turning on small diameter

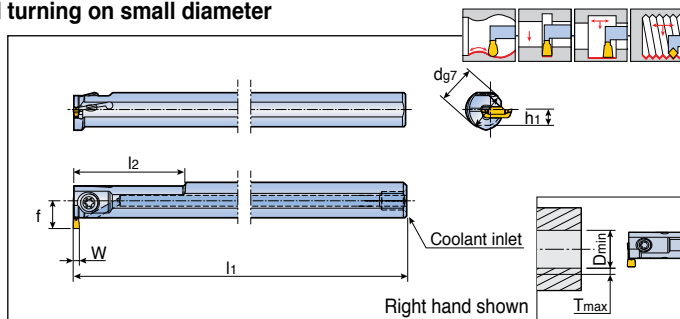

Designation	Insert seat size	Dimension (mm)								Coolant inlet	Insert
		d	l ₁	l ₂	f	h ₁	T _{max}	D _{min}	W		
TGSIR/L 10-13-2	2, 3	10	125	25	7.6	5	2.5	12.5	< 2	Ø3.5	TDIM / TDIP
12-14-2	2, 3	12	125	32	9.0	6	2.5	14.0	< 2	Ø6	B85-B86
16-13-2	2, 3	16	150	20	10.6	8	2.5	13.0	< 2	-	
16-14-2	2, 3	16	150	25	10.9	8	2.5	14.0	< 2	-	
16-16-2	2, 3	16	150	40	10.5	8	2.5	16.0	< 2	-	

Spare parts

Designation	Screw	Wrench	Seal	
TGSIR/L 10/12	TS 40093I	T 15	-	
TGSIR/L 16	TS 40093I	T 15	PL 16 (M6)	

External undercutting

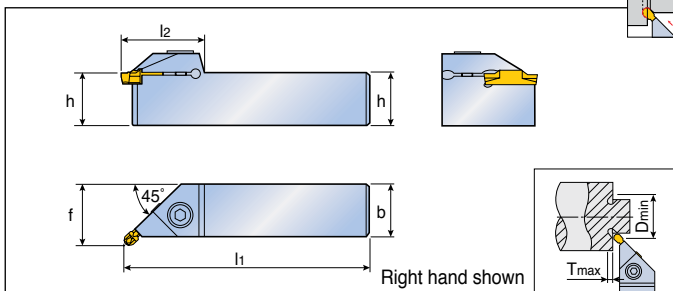

Designation	Insert seat size	Dimension (mm)								Insert
		h	b	l ₁	f	l ₂	T _{max}	D _{min}		
TGEUR/L 1616-3	2, 3	16	16	110	19.3	30	2.8	32	TDT / TDIT B79-B83	
2020-3	2, 3	20	20	125	23.3	30	2.8	32		
2525-3	2, 3	25	25	150	28.3	30	2.8	32		
1616-4	4	16	16	110	19.5	31	2.8	32		
2020-4	4	20	20	125	23.5	31	2.8	32		
2525-4	4	25	25	150	28.5	31	2.8	32		
2525-6	5, 6	25	25	150	28.9	35	3.4	34		

Spare parts

Designation	Screw	Wrench		
TGEUR/L 1616-3	SH M5x0.8x16	L-W4		
TGEUR/L 2020-3	SH M5x0.8x20	L-W4		
TGEUR/L 2525-3	SH M5x0.8x25	L-W4		
TGEUR/L 1616-4	SH M6x1x16	L-W5		
TGEUR/L 2020-4	SH M6x1x20	L-W5		
TGEUR/L 2525-4/6	SH M6x1x25	L-W5		

Internal undercutting

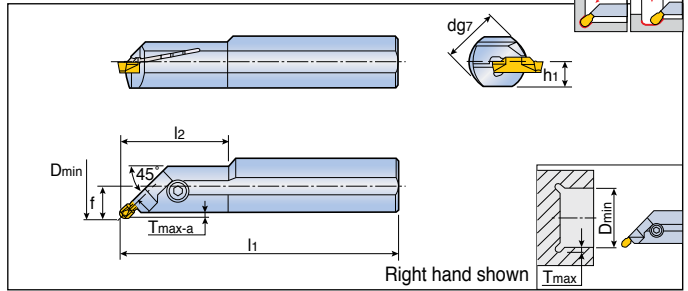

Designation	Insert seat size	Dimension (mm)								Insert
		d	l1	l2	f	h1	Tmax-a	Dmin		
TGIUR/L 20-3	2, 3	20	160	-	12.8	9.5	2.8	38	TDT / TDIT B79-B83	
25-3	2, 3	25	200	40	14.8	11.5	2.8	38		
20-4	4	20	160	-	12.9	9.5	2.8	38		
25-4	4	25	200	40	14.9	11.5	2.8	46		
25-6	5, 6	25	200	-	15.2	11.5	2.8	46		

Spare parts

Designation	Screw	Wrench		
TGIUR/L 20-3	SH M5x0.8x12	L-W4		
TGIUR/L 20-4	SH M5x0.8x16	L-W4		
TGIUR/L 25-3/4	SH M5x0.8x16	L-W4		
TGIUR/L 25-6	SH M6x1x16	L-W5		

TTER/L-15A



Aluminum wheel machining

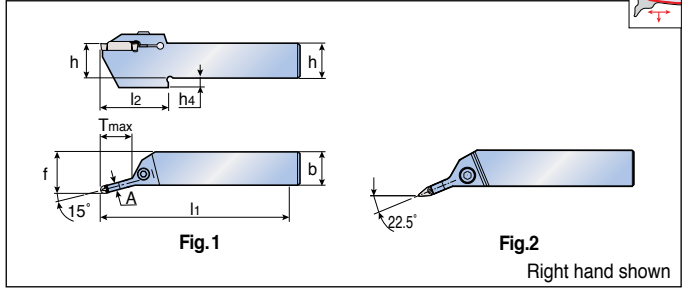

Fig.2
Right hand shown

Designation	Insert seat size	Dimension (mm)								Fig.	Insert
		h	b	l ₁	f	l ₂	A	h ₄	T _{max}		
TTER/L 2525-6-15A	6	25	25	150	30	51	4.90	7	25.0	1	TDA / TSA
2525-8-15A	8	25	25	150	30	55	5.90	7	30.0	1	B87
2525-8V-22.5A*	8	25	25	150	31.7	45	5.85	7	22.0	2	

* For TDA-35V insert

Spare parts

Designation	Screw	Wrench		
TTER/L	SH M6x1x25	L-W5		

Aluminum wheel machining

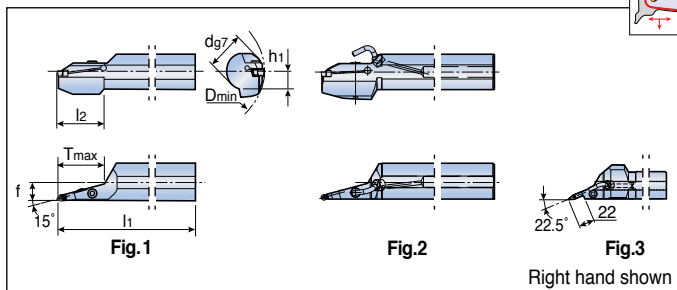

Designation	Insert seat size	Dimension (mm)							Fig.	Coolant	Insert
		d	l ₁	l ₂	f	h ₁	T _{max}	D _{min}			
TGIUR/L40-6-15A	6	40	320	60	19.8	19.0	50.00	160	1	External	TDA / TSA B87
40-6C-15A	6	40	320	60	19.8	19.0	50.00	160	2	Internal	
50-6C-15A	6	50	350	85	25.2	23.5	85.00	200	2	Internal	
40-8-15A	8	40	320	65	20.2	19.0	81.35	160	1	External	
40-8C-15A	8	40	320	85	20.2	19.0	83.00	160	2	Internal	
50-8C-15A	8	50	350	85	25.9	23.5	85.00	200	2	Internal	
40-8VC-22.5A*	8	40	320	85	19.3	19.0	35.00	160	3	Internal	

* For TDA-35V insert

Spare parts

Designation	Screw	Wrench	Seal	Coolant pipe	Coolant nozzle
TGIUR/L	SH M6x1x25	L-W5	PL 40 (R1/8")	NZP5	NZ125

Semi finished holder for TGUX insert

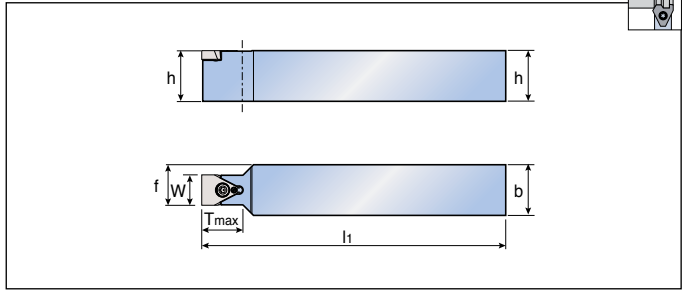

Designation	Dimension (mm)						Insert ⁽¹⁾	
	h	b	f	T _{max}	l _i	W		
TTLEN 1212 K10	12	12	11.0	20	125	10	TGUX B88	
1616 K10	16	16	13.0	20	125	10		
2020 M10	20	20	15.0	20	150	10		
2525 M10	25	25	17.5	20	150	10		
1616 K15	16	16	15.5	20	125	15		
2020 M15	20	20	17.5	20	150	15		
2525 M15	25	25	20.0	20	150	15		
2020 K20	20	20	20.0	35	125	20		
2525 M20	25	25	22.5	35	150	20		
3232 P20	32	32	26.0	35	170	20		
2020 K25	20	20	22.5	35	125	25		
2525 M25	25	25	25.0	35	150	25		
3232 P25	32	32	28.5	35	170	25		

• ⁽¹⁾ Designation of final insert will be different to the semi finished blank

Spare parts

Designation	Screw	Wrench		
TTLEN ...K10/K15/M10/M15	TS 40B100I	T15		
TTLEN ...K20/M20/P20	TS 45120I	T20		
TTLEN ...K25/M25/P25	TS 45120I	T20		

Holders for grooving, parting, turning & reverse turning

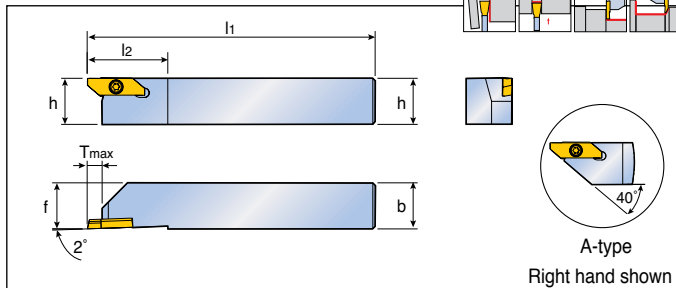

Designation	Dimension (mm)						Insert
	h	b	l ₁	l ₂	T _{max}	f	
TTVER/L 1010-4-A	10	10	125	29	6.7	9.9	TVRR/L TVPR/L B103, B105
1212-4-A	12	12	125	29	6.7	11.9	
1616-4	16	16	125	29	6.5	15.9	
2020-4	20	20	125	29	6.5	19.9	
2525-4	25	25	125	29	6.5	24.9	

• Please keep in your mind selecting right insert

Spare parts

Designation	Screw	Wrench		
	TTVER/L	 CSTB-4SD	 T 8	

Holders for threading & back turning

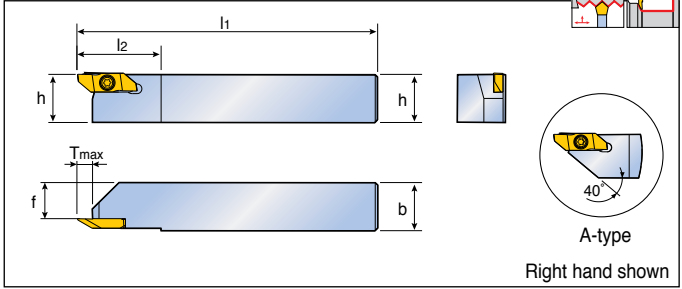

Designation	Dimension (mm)						Insert
	h	b	l ₁	l ₂	T _{max}	f	
TTVBR/L 1010-4-A	10	10	125	29	6.7	5.7	TVBR/L
1212-4-A	12	12	125	29	6.7	7.7	TVTR/L
1616-4	16	16	125	29	6.4	11.7	B104
2020-4	20	20	125	29	6.4	15.7	
2525-4	25	25	125	29	6.4	20.7	

• Please keep in your mind selecting right insert

Spare parts

Designation	Screw 	Wrench 		
TTVBR/L	CSTB-4SD	T 8		

Double ended parting and grooving blades for QUADURSH inserts

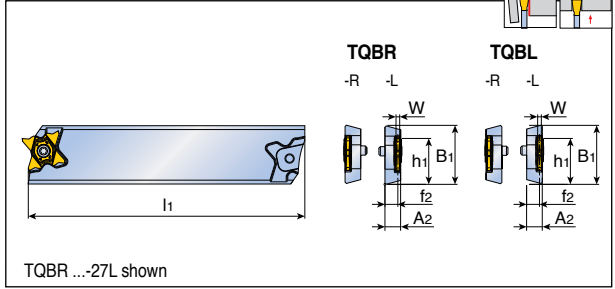
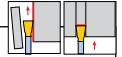

Designation	Dimension (mm)						Block	Insert
	B1	W _{range}	l ₁	h ₁	A ₂	f ₂ *		
TQBR/L 26-27R	26	0.5 ≤ W < 5.3	150	21.4	8.5	7	TTBN/U...-26	TQ... 27
26-27L	26	0.5 ≤ W < 5.3	150	21.4	8.5	7	TTBN/U...-26	B107-B116
32-27R	32	0.5 ≤ W < 5.3	150	24.9	8.5	7	TTBN/U...-32	
32-27L	32	0.5 ≤ W < 5.3	150	24.9	8.5	7	TTBN/U...-32	

* : To the center of inserts up to 3.2mm width

Spare parts

Designation	Screw	Wrench		
TQBR/L 26-27R	TS 50125I	T 10/20		
TQBR/L 26-27L	TS 50125IL	T 10/20		
TQBR/L 32-27R	TS 50125I	T 10/20		
TQBR/L 32-27L	TS 50125IL	T 10/20		



Integral shank toolholders

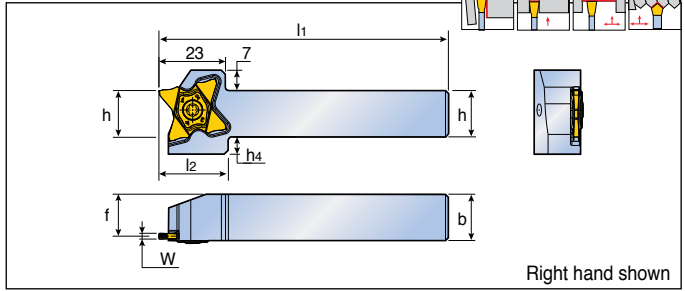

Designation	Dimension (mm)							Insert
	h	b	W _{range}	f ⁽²⁾	l ₁	l ₂	h ₄	
TQHR/L 10-27	10	10	0.5 ≤ W < 5.3	8.5	120	24	9	TQ.. 27
12-27	12	12	0.5 ≤ W < 5.3	10.5	120	24	8	
16-27	16	16	0.5 ≤ W < 5.3	14.5	120	24	6	B107-B116
20-27	20	20	0.5 ≤ W < 5.3	18.5	120	24	2	
25-27	25	25	0.5 ≤ W < 5.3	23.5	135	-	-	
16-27-8 ⁽¹⁾	16	16	5.3 ≤ W ≤ 8.2	14.0	120	24	6	TQS 27
20-27-8 ⁽¹⁾	20	20	5.3 ≤ W ≤ 8.2	18.0	120	24	2	
25-27-8 ⁽¹⁾	25	25	5.3 ≤ W ≤ 8.2	23.0	135	-	-	B113-B116

- ⁽¹⁾ Only for TQS wider inserts from 5.3mm-8.2mm width
- ⁽²⁾ "f" value is based on TQ.. 27 standard insert

Spare parts

Designation	Screw	Wrench		
TQHR/L 10/12/16/20/25	TS 50125I ⁽¹⁾	T 10/20		
	TS 50125IL ⁽²⁾	T 10/20		
TQHR/L 16/20/25-27-8	TS 501701I-IC ⁽³⁾	T 15		
	TS 501701IL-IC ⁽⁴⁾	T 15		

• ⁽¹⁾(³) For left holder

• ⁽²⁾(⁴) For right holder

Grooving and turning with channels for high pressure coolant



T-BURST
HIGH PRESSURE

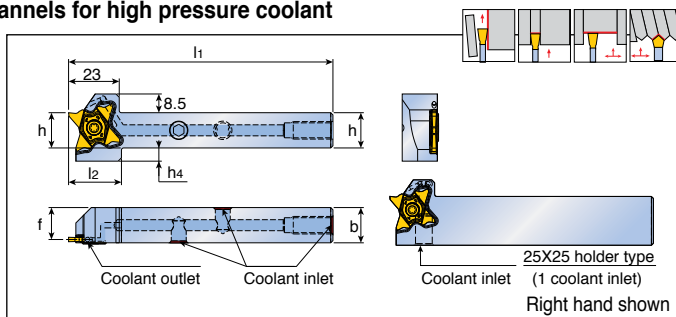

Designation	Dimension (mm)						Coolant inlet	Insert
	h	b	l ₁	f	l ₂	h ₄		
TQHR/L 12-27-TB	12	12	120	10.5	24	8	UNF 5/16	TQ.. 27 B107-B116
16-27-TB	16	16	120	14.5	24	6	UNF 5/16	
20-27-TB	20	20	120	18.5	24	2	G1/8 BSPP	
25-27-TB	25	25	135	23.5	-	-	G1/8 BSPP	

	70 bar flow rate (l/min)	100 bar flow rate (l/min)	140 bar flow rate (l/min)
TQHR/L- TB	9-11	11-13	12-14

• Please refer to B69 page for T-Burst accessories

Spare parts

Designation	Screw	Wrench	Inlet plug	Wrench for inlet plug
TQHR/L 12-27-TB				
TQHR/L 16-27-TB	TS 50125I ⁽¹⁾ TS 50125IL ⁽²⁾	T 10/20	PLG 5/16 UNF	L-W 5/32"
TQHR/L 20-27-TB		T 10/20	PLG 5/16 UNF	L-W 5/32"
TQHR/L 25-27-TB		T 10/20	PLG G1/8-L6.5	L-W 5
		T 10/20	-	-



• ⁽¹⁾ For TQHL • ⁽²⁾ For TQHR

Perpendicular integral shank toolholders

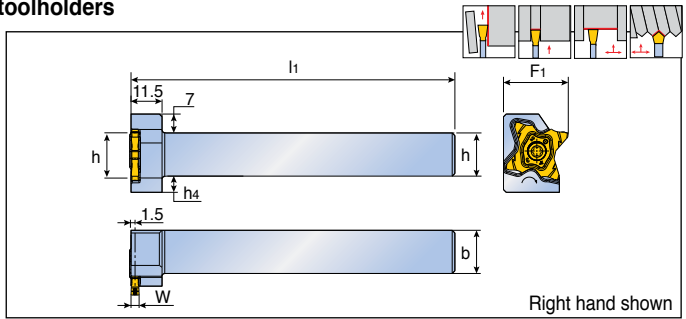

Designation	Dimension (mm)						Insert
	h	b	W _{range}	F1	l ₁	h ₄	
TQHPR/L 16-27	16	16	$0.5 \leq W < 5.3$	24	120	6	TQ.. 27
20-27	20	20	$0.5 \leq W < 5.3$	28	120	2	B107-B116
25-27	25	25	$0.5 \leq W < 5.3$	33	135	-	
16-27-8⁽¹⁾	16	16	$5.3 \leq W \leq 8.2$	24	120	6	TQS 27
20-27-8⁽¹⁾	20	20	$5.3 \leq W \leq 8.2$	28	120	2	B113-B116
25-27-8⁽¹⁾	25	25	$5.3 \leq W \leq 8.2$	33	135	-	

⁽¹⁾ Only for TQS wider inserts from 5.3mm-8.2mm width

Spare parts

Designation	Screw	Wrench		
TQHPR/L 16/20/25	TS 501251 ⁽¹⁾	T 20		
	TS 501251L ⁽²⁾	T 20		
TQHPR/L 16/20/25-8	TS 501701-IC ⁽³⁾	T 15		
	TS 501701IL-IC ⁽⁴⁾	T 15		



• ⁽¹⁾/⁽³⁾ For right holder • ⁽²⁾/⁽⁴⁾ For left holder

Hose

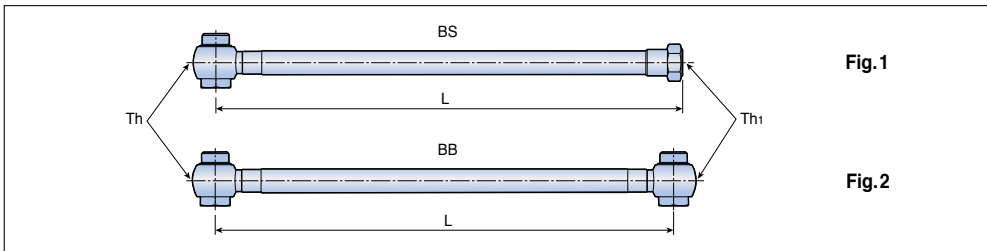

Fig. 1

Fig. 2

Designation	Dimension				Max.pressure(Bar)	Fig.
	L(mm)	Th	Th1			
TB HOSE G1/8"-7/16"-200BS	200	G1/8"-28 BSPP	7/16"-20 UNF (Flare 37°)		260	1
G1/8"-7/16"-250BS	250	G1/8"-28 BSPP	7/16"-20 UNF (Flare 37°)		260	1
G1/8"-G1/8"-200BB	200	G1/8"-28 BSPP	G1/8"-28 BSPP		260	2
G1/8"-G1/8"-250BB	250	G1/8"-28 BSPP	G1/8"-28 BSPP		260	2
5/16"-7/16"-200BS	200	5/16"-24 UNF	7/16"-20 UNF (Flare 37°)		200	1
5/16"-G1/8"-200BS	200	5/16"-24 UNF	G1/8"-28 BSPP		200	1

• Hose is ordered separately

Adapter

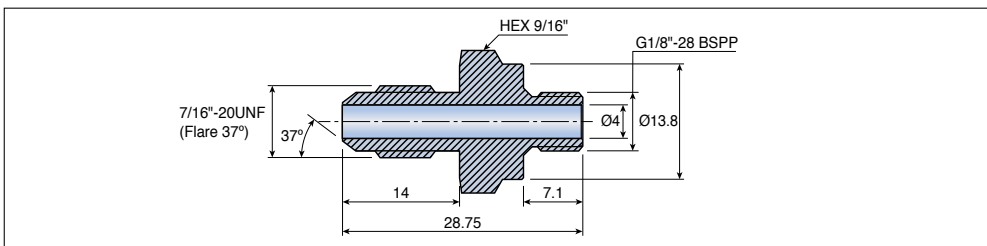

Designation

TB NIPPLE G1/8-7/16 UNF

• Adapter is ordered separately

Seal washer

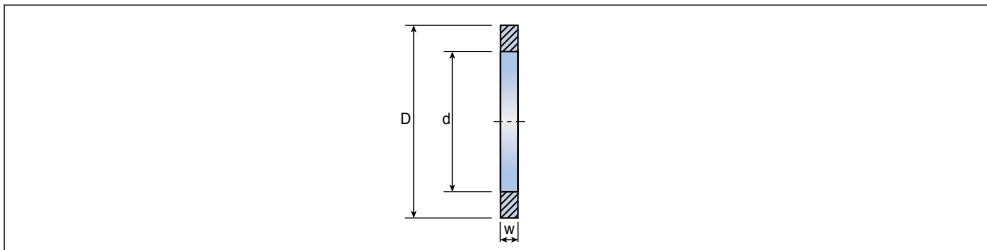

Designation	Dimension (mm)		
	D	d	w
TB COPPER SEAL 1/8"	15	10	1
SEAL 5/16"	12	8	1

• Seal washer is ordered separately

Connector

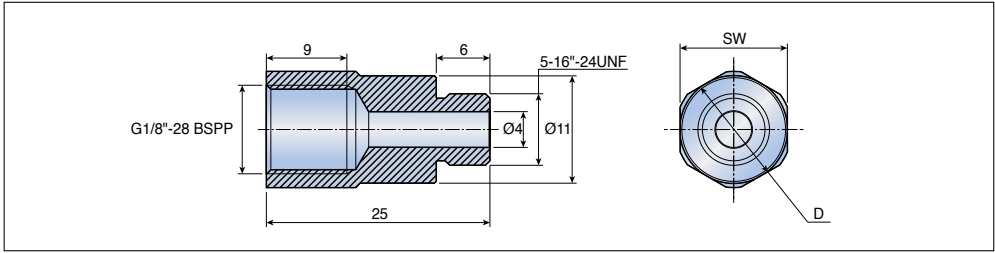

Designation	Dimension (mm)	
	D	SW
TB CONECTOR 5/16"-G1/8"	13	12
5/16"-G1/8"-12	12	11

• Connector is ordered separately

Coupling system

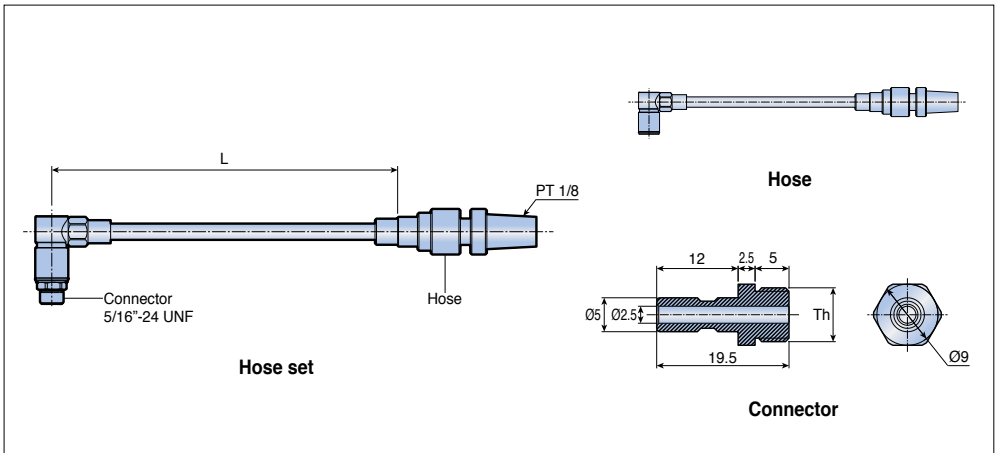

Components	Designation	Dimension			
		L (mm)	Th	Maximum pressure (Bar)	
Hose set	S-TB HOSE	R1/8-COUPLE-100	100	-	140
		R1/8-COUPLE-200	200	-	140
		R1/8-COUPLE-300	300	-	140
Hose	TB HOSE	R1/8-COUPLE-200	200	-	140
		R1/8-COUPLE-300	300	-	140
Connector	TB CONECTOR	5/16-COUPLE	-	5/16"-24 UNF	-
		G1/8-COUPLE	-	G1/8"-28 BSPP	-
		R1/8-COUPLE	-	PT 1/8"	-

• Hose set, hose and connector are ordered separately

Parting & Grooving Inserts and Solid Bars



Insert Designation System

Parting and grooving



1 TaeguTec

2 Cutting edge type

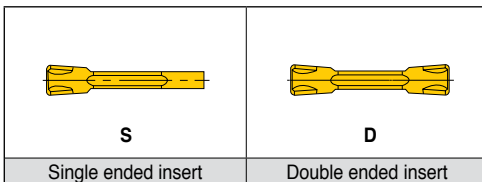

3 Chip breaker type

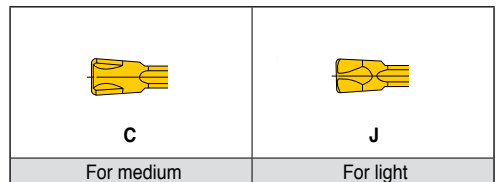

4 Width of insert

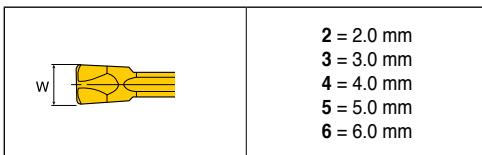

5 Lead angle

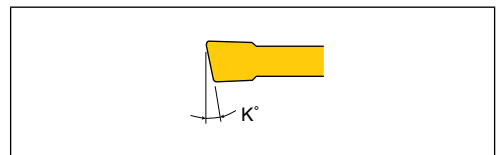

6 Hand of insert

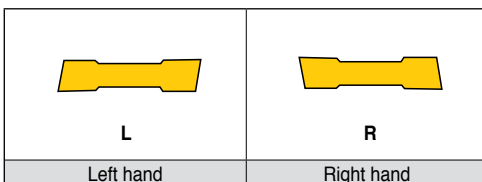

7 Corner type

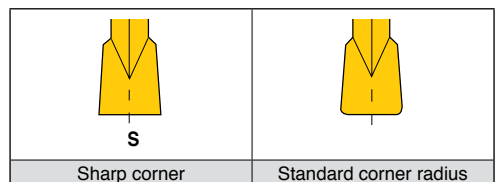

Insert Designation System



Turning, grooving and face machining

T **D** **(F)** **T** **3.00** **E** - **0.40** **R**

1 2 3 4 5 6 7 8

1 TaeguTec

2 Cutting edge type

	
S	D
Single ended insert	Double ended insert

3 Application type

F	Face turning and grooving
I	Internal turning and grooving
X	Universal

4 Chip breaker type

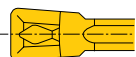
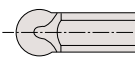
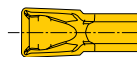
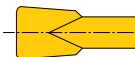
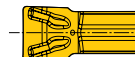
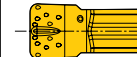
					
T	A	U	G	M	P
For steel, high-temp. alloy and cast iron	For aluminum	Universal chip breaker	Without chip breaker	Pressed for small diameter	Ground for small diameter

5 Width of insert (mm)

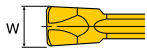
	<input type="checkbox"/> . <input type="checkbox"/> . <input type="checkbox"/> Precision insert
	<input type="checkbox"/> Pressed insert



6 Application type

E	For turning and grooving
No designation	For precision grooving

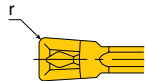
7 Corner radius (mm)

	<input type="checkbox"/> . <input type="checkbox"/> . <input type="checkbox"/> Precision insert
	<input type="checkbox"/> . <input type="checkbox"/> Pressed insert

8 Hand of insert - For face machining

	
L	R
Left hand insert on left hand holder	Right hand insert on right hand holder

Double ended inserts for parting and grooving with "C" type chip breaker

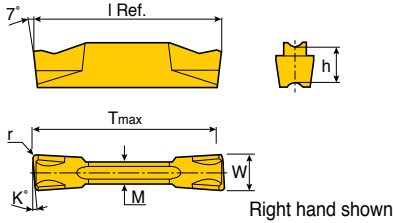

Size	Dimension (mm)						
	W±0.05	r	M	l	K	h	Tmax
2 (.R/L)	2.0	0.20	1.7	20.0	0-15	4.7	19
2 RS/LS	2.0	0.02	1.7	19.6	15	4.7	19
3 (.R/L)	3.0	0.20	2.4	20.0	0-15	4.7	19
3 RS/LS	3.0	0.02	2.4	19.6	6-15	4.7	19
4 (.R/L)	4.0	0.30	3.0	20.0	0-15	4.7	19
5 (.R/L)	5.0	0.30	4.0	25.0	0-4	5.2	24
6	6.0	0.30	5.0	25.0	-	5.2	24
8	8.0	0.40	6.0	30.0	-	6.4	29

Insert	Designation	Insert seat size	Feed (mm/rev)	Cermet		Coated				Uncoated		
				PV3030	CT3000	TT7505	TT6080	TT5100	TT9080	TT7220	TT8020	K10
	TDC 2	2	0.05-0.18	●	●				●	●	●	●
	2-6R/L	2	0.04-0.14						●	●	●	●
	2-8R/L	2	0.04-0.14							●	●	
	2-15R/L	2	0.04-0.12						●	●	●	
	2-15RS/LS	2	0.02-0.12						●	●	●	
	3	3	0.07-0.25	●	●				●	●	●	●
	3-6R/L	3	0.06-0.18						●	●	●	●
	3-6RS/LS	3	0.03-0.18						●	●		
	3-15R/L	3	0.06-0.16						●	●	●	
	3-15RS/LS	3	0.03-0.16							●	●	
	4	4	0.08-0.30		●				●	●	●	●
	4-4R/L	4	0.06-0.24						●	●	●	●
	4-15R/L	4	0.06-0.22							●	●	
	5	5	0.09-0.35		●				●	●	●	●
	5-4R/L	5	0.07-0.28						●	●	●	
	6	6	0.12-0.40		●				●	●	●	●
8	8	0.14-0.43						●		●		

●: Standard items

Dmax (mm) for parting & grooving

Insert	Dmax (mm)
TDC 2-15 RS/LS	28
TDC 3-15 RS/LS	29
TDC 4-5 R/L	30

- Standard holders (except TGFR xxxx) will be damaged if workpiece diameter goes over the dimension of each insert in the table.



Single ended inserts for deep grooving and parting with "C" type chip breaker

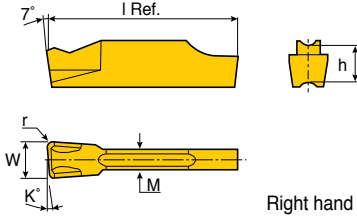

Size	Dimension (mm)					
	W±0.05	r	M	I	K	h
2 (.R/L)	2.0	0.20	1.7	20.0	0-15	4.7
2 RS/LS	2.0	0.02	1.7	19.6	15	4.7
3 (.R/L)	3.0	0.20	2.4	20.0	0-15	4.7
3 RS/LS	3.0	0.02	2.4	19.6	15	4.7
4 (.R/L)	4.0	0.30	3.0	20.0	0-15	4.7
5 (.R/L)	5.0	0.30	4.0	25.0	0-4	5.2
6	6.0	0.30	5.0	25.0	-	5.2
8	8.0	0.40	6.0	30.0	-	6.4

Insert	Designation	Insert seat size	Feed (mm/rev)	Cermet			Coated			Uncoated				
				PV3030	CT3000		TT7505	TT6080	TT5100	TT9080	TT7220	TT8020	K10	
	TSC 2	2	0.05-0.18						●	●	●	●		
	2-6R/L	2	0.04-0.14						●	●	●	●		
	2-8R/L	2	0.04-0.14							●	●			
	2-15R/L	2	0.04-0.12							●	●			
	2-15RS/LS	2	0.02-0.12							●	●			
	3	3	0.07-0.25						●	●	●	●		
	3-6R/L	3	0.06-0.18						●	●	●	●		
	3-15R/L	3	0.06-0.16							●	●			
	3-15RS/LS	3	0.03-0.16							●	●			
	4	4	0.08-0.30						●	●	●			
	4-4R/L	4	0.06-0.24						●	●	●	●		
	4-6R/L	4	0.06-0.23							●	●	●		
	4-15R/L	4	0.06-0.22							●	●			
	5	5	0.09-0.35						●	●	●	●		
	5-4R/L	5	0.07-0.28							●	●	●	●	
6	6	0.12-0.40						●	●	●	●			
8	8	0.14-0.43						●	●	●				

●: Standard items

Dmax (mm) for parting & grooving

Insert	Dmax (mm)
TSC 3-15 R/L	96

• Standard holders (except TGFR xxxx) will be damaged if workpiece diameter goes over the dimension of each insert in the table.



Double ended inserts for parting and grooving with "J" type chip breaker

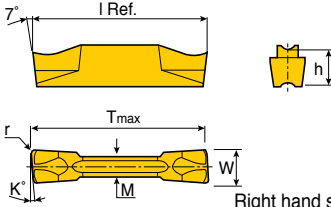

Right hand shown

Size	Dimension (mm)						
	W±0.05	r	M	l	K	h	Tmax
1.4	1.4	0.16	1.0	16.0	-	4.0	15
2 (.R/L)	2.0	0.20	1.7	20.0	0-15	4.7	19
2 RS/LS	2.0	0.02	1.7	19.6	6-15	4.7	19
3 (.R/L)	3.0	0.20	2.4	20.0	0-15	4.7	19
3 RS/LS	3.0	0.02	2.4	19.6	6-15	4.7	19
4 (.R/L)	4.0	0.30	3.0	20.0	0-15	4.7	19
5 (.R/L)	5.0	0.30	4.0	25.0	0-4	5.2	24
6	6.0	0.30	5.0	25.0	-	5.2	24

Insert	Designation	Insert seat size	Feed (mm/rev)	Cermet			Coated				Uncoated		
				PV3030	CT3000		TT7505	TT6080	TT15100	TT9080	TT7220	TT8020	K10
	TDJ 1.4	1	0.02-0.10						●		●		
	2	2	0.04-0.12						●	●	●	●	
	2-6R/L	2	0.03-0.08						●	●	●	●	
	2-6RS/LS	2	0.03-0.07						●	●	●		
	2-8R/L	2	0.03-0.08						●	●	●		
	2-15R/L	2	0.03-0.08						●	●	●		
	2-15RS/LS	2	0.03-0.07						●	●	●		
	3	3	0.04-0.16		●				●	●	●	●	
	3-6R/L	3	0.03-0.12						●	●	●	●	
	3-6RS/LS	3	0.03-0.10							●	●		
	3-15R/L	3	0.03-0.12						●	●	●		
	3-15RS/LS	3	0.03-0.10							●	●		
	4	4	0.05-0.18						●	●	●	●	
	4-4R/L	4	0.05-0.14						●	●	●	●	
	4-15R/L	4	0.05-0.12							●	●	●	
	5	5	0.05-0.20						●	●	●	●	
	5-4R/L	5	0.05-0.16							●	●	●	
	6	6	0.05-0.22						●	●	●	●	

●: Standard items

Dmax (mm) for parting & grooving

Insert	Dmax (mm)
TDJ 2-15 RS/LS	28
TDJ 3-15 RS/LS	29
TDJ 4-15 R/L	30

- Standard holders (except TGFR xxxx) will be damaged if workpiece diameter goes over the dimension of each insert in the table.



B130

Single ended inserts for deep grooving and parting with "J" type chip breaker

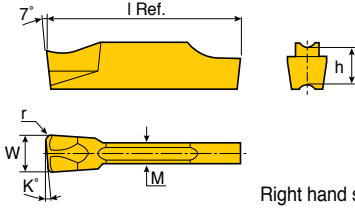

Right hand shown

Size	Dimension (mm)					
	W±0.05	r	M	I	K	h
2 (.R/L)	2.0	0.20	1.7	20.0	0-15	4.7
2 RS/LS	2.0	0.02	1.7	19.8	15	4.7
3 (.R/L)	3.0	0.20	2.4	20.0	0-15	4.7
3 RS/LS	3.0	0.02	2.4	19.8	6-15	4.7
4 (.R/L)	4.0	0.30	3.0	20.0	0-6	4.7
5 (.R/L)	5.0	0.30	4.0	25.0	0-4	5.2
6	6.0	0.30	5.0	25.0	-	5.2

Insert	Designation	Insert seat size	Feed (mm/rev)	Cermet			Coated			Uncoated			
				PV3030	CT3000		TT7505	TT6080	TT5100	TT9080	TT7220	TT8020	K10
	TSJ 2	2	0.04-0.12						●	●	●	●	
	2-6R/L	2	0.03-0.08							●	●	●	
	2-15R/L	2	0.03-0.08							●	●		
	2-15RS/LS	2	0.03-0.08							●	●		
	2-8R/L	2	0.03-0.07								●		
	3	3	0.04-0.16						●	●	●	●	
	3-6R/L	3	0.03-0.12						●	●	●	●	
	3-6RS/LS	3	0.03-0.10						●	●	●		
	3-15R/L	3	0.03-0.12							●	●		
	3-15RS/LS	3	0.03-0.10							●	●		
	4	4	0.05-0.18						●	●	●	●	
	4-4R/L	4	0.05-0.14							●	●		
	4-6R/L	4	0.05-0.12							●			
	5	5	0.05-0.20						●	●	●	●	
	5-4R/L	5	0.05-0.16							●	●		
	6	6	0.05-0.22						●	●	●	●	

●: Standard items

Dmax (mm) for parting & grooving

Insert	Dmax (mm)
TSJ 3-15 R/L	103
TSJ 3-15 RS/LS	34

• Standard holders (except TGFR xxxx) will be damaged if workpiece diameter goes over the dimension of each insert in the table.



TDXU-E

Pressed inserts for external, internal, face turning, grooving and parting

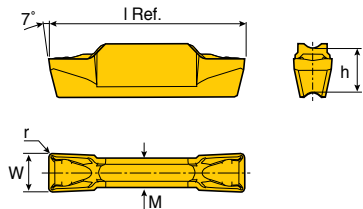

Size	Dimension (mm)				
	W±0.05	r	M	l	h
2E-0.3	2.0	0.3	1.7	20.0	4.7
3E-0.3	3.0	0.3	2.2	20.0	4.7
4E-0.4	4.0	0.4	3.0	20.0	4.7
4E-0.8	4.0	0.8	3.0	20.0	4.7
5E-0.4	5.0	0.4	4.0	25.0	5.2
5E-0.8	5.0	0.8	4.0	25.0	5.2
6E-0.4	6.0	0.4	5.0	25.0	5.2
6E-0.8	6.0	0.8	5.0	25.0	5.2
8E-0.8	8.0	0.8	6.0	30.0	6.4

Insert	Designation	Insert seat size	Turning		Grooving	Cermet		Coated				Uncoated			
			Feed (mm/rev)	ap (mm)	Feed (mm/rev)	PV3030	CT3000	TT7505	TT6080	TT8125	TT5100	TT9080	TT7220	TT8020	K10
	TDXU 2E-0.3	2	0.12-0.18	0.4-1.2	0.03-0.18			●	●		●	●	●	●	●
	3E-0.3	3	0.15-0.19	0.4-1.8	0.07-0.11	●	●	●	●	●	●	●	●	●	●
	4E-0.4	4	0.18-0.24	0.5-2.4	0.09-0.15	●	●	●	●	●	●	●	●	●	●
	4E-0.8	4	0.18-0.24	1.0-2.4	0.09-0.15		●	●	●	●	●	●	●	●	●
	5E-0.4	5	0.20-0.30	0.5-3.0	0.11-0.20		●	●	●		●	●	●	●	●
	5E-0.8	5	0.23-0.35	1.0-3.0	0.11-0.21		●	●	●		●	●	●	●	●
	6E-0.4	6	0.22-0.36	0.5-3.6	0.13-0.23			●	●	●	●	●	●	●	●
	6E-0.8	6	0.24-0.42	1.0-3.6	0.13-0.25			●	●	●	●	●	●	●	●
8E-0.8	8	0.30-0.56	1.0-4.8	0.15-0.34			●	●		●	●	●	●	●	



●: Standard items

TDXT-E

Pressed inserts for external, internal, face turning and grooving

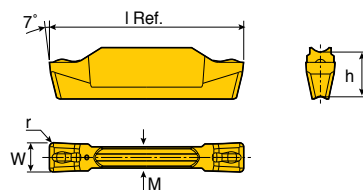

Size	Dimension (mm)				
	W±0.05	r	M	l	h
3E-0.4	3.0	0.4	2.2	20.0	4.7
4E-0.4	4.0	0.4	3.0	20.0	4.7
5E-0.4	5.0	0.4	4.0	25.0	5.2
6E-0.8	6.0	0.8	5.0	25.0	5.2
8E-0.8	8.0	0.8	6.0	30.0	6.4

Insert	Designation	Insert seat size	Turning		Grooving	Cermet		Coated				Uncoated		
			Feed (mm/rev)	ap (mm)	Feed (mm/rev)	PV3030	CT3000	TT7505	TT6080	TT5100	TT9080	TT7220	TT8020	K10
	TDXT 3E-0.4	3	0.15-0.22	0.5-1.8	0.07-0.15			●	●	●	●		●	
	4E-0.4	4	0.18-0.30	0.5-2.4	0.09-0.18			●	●	●	●		●	
	5E-0.4	5	0.20-0.35	0.5-3.0	0.11-0.20			●	●	●	●		●	
	6E-0.8	6	0.24-0.42	1.0-3.6	0.13-0.30			●	●	●	●		●	
	8E-0.8	8	0.30-0.56	1.0-4.8	0.15-0.40			●	●	●	●		●	



● Non-standard grade production available at the customer's request

●: Standard items

Precision inserts for external grooving only

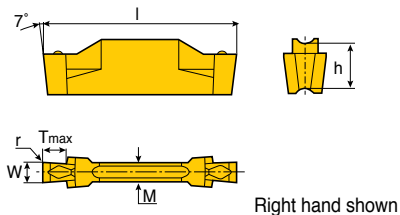

Size	Dimension (mm)					
	W±0.02	r ±0.05	M	l	Tmax	h
1.00	1.00	0.00	2.2	20.0	2.5	4.7
1.30	1.30	0.00	2.2	20.0	2.5	4.7
1.60	1.60	0.10	2.2	20.0	2.5	4.7
1.85	1.85	0.10	2.2	20.0	3.5	4.7
2.15	2.15	0.15	2.2	20.0	3.5	4.7

Insert	Designation	Insert seat size	Grooving	Cermet		Coated					Uncoated	
			Feed (mm/rev)	PV3030	CT3000	TT7505	TT6980	TT5100	TT9080	TT7220	TT8020	K10
	TDT 1.00-0.00*	2	0.02-0.04						●	●	●	
	1.30-0.00*	2	0.02-0.05						●	●	●	
	1.60-0.10*	2	0.03-0.07						●	●	●	
	1.85-0.10*	2	0.03-0.09						●	●	●	
	2.15-0.15	2	0.03-0.10						●	●	●	



•*: Only for grooving. Please use TGFR/L ...-4 holder

●: Standard items

TDT-E

Pressed inserts for external turning and grooving

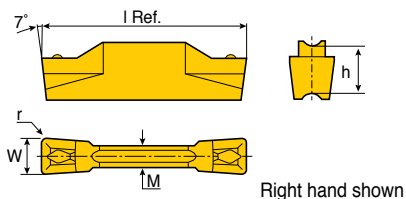

Size	Dimension (mm)				
	W±0.05	r	M	l	h
3	3.0	0.4	2.2	20.0	4.7
4	4.0	0.4	3.0	20.0	4.7
6	6.0	0.8	5.0	25.0	5.2

Insert	Designation	Insert seat size	Turning		Grooving	Cermet			Ceramic					Coated	Uncoated	
			Feed (mm/rev)	ap (mm)	Feed (mm/rev)	PV3030	CT3000	AB30	TT7505	TT6080	TT8125	TT5100	TT9080	TT7220	TT8020	K10
	TDT 3E-0.4	3	0.15-0.22	0.5-1.8	0.07-0.15	●			●	●	●	●	●	●	●	●
	4E-0.4	4	0.18-0.30	0.5-2.4	0.09-0.18	●			●	●		●	●	●		●
	4E-0.4T CE⁽¹⁾	4	0.18-0.30	0.5-2.4	0.09-0.35			●								
	6E-0.8T CE⁽¹⁾	6	0.24-0.42	1.0-3.6	0.13-0.40			●								



• ⁽¹⁾This insert is a pressed ceramic insert

●: Standard items

Precision inserts for external turning and grooving

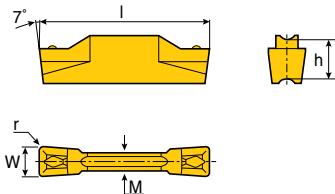

Size	Dimension (mm)				
	W±0.02	r	M	l	h
2.65 / 3.00 / 3.15	2.65-3.15	0.15-0.40	2.2	20.0	4.7
4.00 / 4.15	4.00-4.15	0.15-0.80	3.0	20.0	4.7
4.78 / 5.00 / 5.15	4.78-5.15	0.15-0.80	4.0	25.0	5.2
6.00	6.00	0.80-1.20	5.0	25.0	5.2
8.00	8.00	0.80-1.20	6.0	30.0	6.4
10.00	10.00	0.80-2.00	8.0	30.0	6.4

Insert	Designation	Insert seat size	Turning		Grooving	Cermet		Coated				Uncoated	
			Feed (mm/rev)	ap (mm)	Feed (mm/rev)	PV3030	CT3000	TT7505	TT6080	TT15100	TT9080	TT7220	TT8020
	TDT 2.65E-0.15	3	0.10-0.18	0.2-1.8	0.05-0.12				●	●	●	●	
	3.00E-0.20	3	0.12-0.20	0.3-2.0	0.07-0.13				●	●	●	●	
	3.00E-0.40	3	0.15-0.22	0.5-2.0	0.07-0.15				●	●	●	●	
	3.15E-0.15	3	0.15-0.22	0.2-2.0	0.07-0.15				●	●	●	●	
	4.00E-0.40	4	0.18-0.30	0.5-2.4	0.09-0.18				●	●	●	●	
	4.00E-0.80	4	0.18-0.30	1.0-2.4	0.09-0.18				●	●	●	●	
	4.15E-0.15	4	0.18-0.30	0.5-2.4	0.09-0.18				●	●	●	●	
	4.78E-0.55	5	0.20-0.35	0.7-2.8	0.10-0.20				●	●	●	●	
	5.00E-0.40	5	0.20-0.35	0.5-2.3	0.11-0.20				●	●	●	●	
	5.00E-0.80	5	0.23-0.35	1.0-3.0	0.11-0.21				●	●	●	●	
	5.15E-0.15	5	0.23-0.35	0.2-3.0	0.11-0.21				●	●	●	●	
	6.00E-0.80	6	0.24-0.42	1.0-3.6	0.13-0.30				●	●	●	●	
	6.00E-1.20	6	0.24-0.42	1.3-3.6	0.13-0.30				●	●	●	●	
	8.00E-0.80	8	0.30-0.56	1.0-4.8	0.15-0.40				●	●	●	●	
	8.00E-1.20	8	0.30-0.56	1.3-4.8	0.15-0.40				●	●	●	●	
	10.00E-0.80	10	0.35-0.65	1.0-6.0	0.20-0.45				●				
10.00E-1.20	10	0.40-0.80	1.0-6.0	0.20-0.45				●	●				
10.00E-2.00	10	0.35-0.80	1.0-6.0	0.20-0.45				●	●				

●: Standard items



B131

Pressed inserts for face grooving and turning

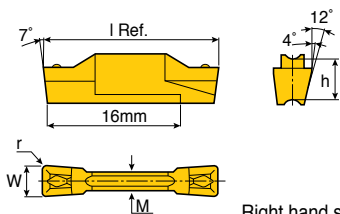

Right hand shown

Size	Dimension (mm)				
	W±0.05	r	M	l	h
3E	3.0	0.40	2.2	20.0	4.7
4E	4.0	0.40	3.0	20.0	4.7
4E... CE	4.0	0.40	3.0	20.0	4.7

Insert	Designation	Insert seat size	Turning		Grooving	Cermet		Ceramic		Coated			Uncoated
			Feed (mm/rev)	ap (mm)	Feed (mm/rev)	PV3030	CT3000	AB30	TT7505	TT6080	TT5100	TT9080	TT7220
	TDFT 3E-0.4R/L	3	0.15-0.22	0.5-2.0	0.07-0.15						●	●	●
	4E-0.4R/L	4	0.18-0.30	0.5-2.4	0.09-0.18						●	●	●
	4E-0.4TR/L CE⁽¹⁾	4	0.18-0.30	0.5-2.4	0.09-0.35			●					



- Apply R insert on R tool and L insert on L tool
- ⁽¹⁾ This insert is a pressed ceramic insert

●: Standard items

TDIT-E (Full-Radius)

Precision inserts for internal turning, grooving, profiling and undercutting

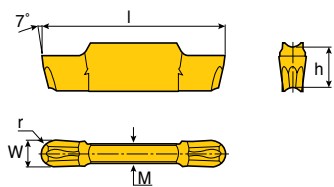

Size	Dimension (mm)				
	W±0.02	r±0.05	M	l	h
3	3.00	1.50	2.2	20.0	4.7
4	4.00	2.00	3.0	20.0	4.7
5	5.00	2.50	4.0	25.0	5.2
6	6.00	3.00	5.0	25.0	5.2

Insert	Designation	Insert seat size	Turning		Grooving	Cermet		Coated			Uncoated	
			Feed (mm/rev)	ap (mm)	Feed (mm/rev)	PV3030	CT3000	TT7505	TT6080	TT5100	TT9080	TT7220
	TDIT 3.00E-1.50	3	0.15-0.28	0.0-1.5	0.08-0.18						●	●
	4.00E-2.00	4	0.18-0.35	0.0-2.0	0.10-0.20				●	●	●	●
	5.00E-2.50	5	0.20-0.42	0.0-2.5	0.12-0.23				●	●	●	●
	6.00E-3.00	6	0.25-0.54	0.0-3.0	0.15-0.27				●	●	●	●



●: Standard items

MIN	T	R	04	040	005	D010
1	7	2	3	4	5	6

1 TOPMICRO series

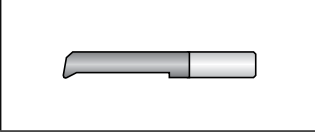

2 Hand of tool

R Right-hand
L Left-hand

3 Shank dia.

04 4.0mm
07 7.0mm

4 Max. depth

050 5.0mm
140 14.0mm

5 Corner radius

010 0.10mm
020 0.20mm

6 Min. bore dia.

D010 1.0mm

7 Application type

T	Turning and chamfering
B	Back turning
P	Turning and profiling
U	Undercutting and chamfering
C	Turning and 45° chamfering
G	Grooving and turning
A	Grooving along shaft
F	Face grooving
R	Full radius for internal boring and profiling
N	ISO full profile internal threading
SL	Sleeve for MINS

Sleeves

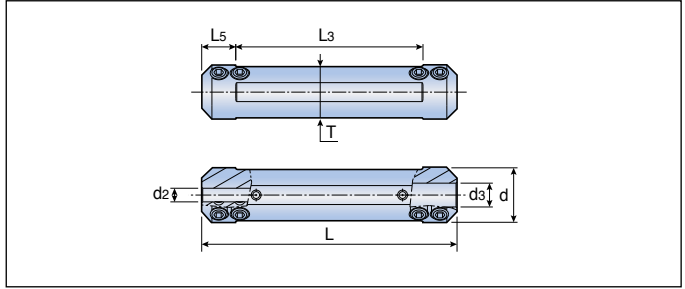

Designation	Dimension (mm)						
	d	d2	d3	L	L5	L3	T
MINSL 12-4-4	12.00	4.00	4.00	75.00	10.00	55.00	10.30
14-4-4	14.00	4.00	4.00	75.00	10.00	55.00	12.00
16-4-7	16.00	4.00	7.00	75.00	10.00	55.00	15.00
20-4-7	20.00	4.00	7.00	90.00	10.00	70.00	18.00
22-4-7	22.00	4.00	7.00	90.00	10.00	70.00	20.00
25-4-7	25.00	4.00	7.00	100.00	10.00	80.00	23.00

Spare parts

Designation	Set screw	Wrench		
MINSL 12	SS M5x0.8x4-MG	L-W 2.5		
MINSL 14/16/20/22/25	SS M5x0.8x6-MG	L-W 2.5		

MINS ...-L100C

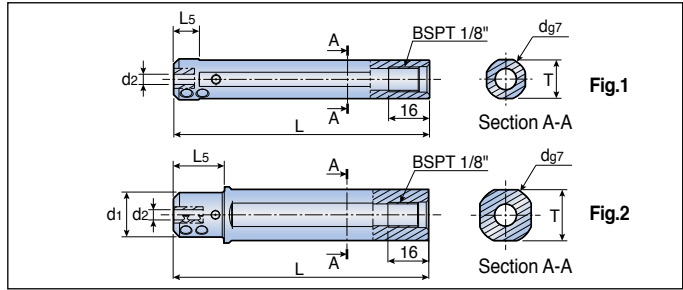

Sleeves for direct connection for coolant



Designation	Dimension (mm)						Fig.
	d	d1	d2	L	L5	T	
MINS 16-4-L100C	16.00	-	4.00	100.00	10.00	15.00	1
16-7-L100C	16.00	-	7.00	100.00	10.00	15.00	1
20-4-L100C	20.00	17.50	4.00	100.00	20.00	18.00	2
20-7-L100C	20.00	17.50	7.00	100.00	20.00	18.00	2
22-4-L100C	22.00	17.50	4.00	100.00	20.00	20.00	2
22-7-L100C	22.00	17.50	7.00	100.00	20.00	20.00	2
25-4-L100C	25.00	18.00	4.00	100.00	23.00	23.00	2
25-7-L100C	25.00	18.00	7.00	100.00	23.00	23.00	2

• All sleeves applicable for Citizen Swiss type machine

Spare parts

Designation	Set screw	Wrench		
				
MINS ...-L100C	SS M5x0.8x6-MG	L-W 2.5		

Mini carbide bars for internal turning and chamfering

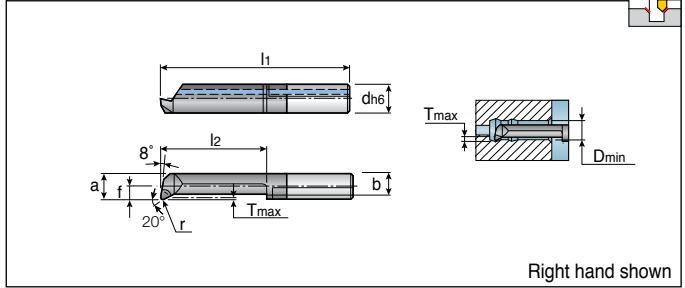

Designation	Dimension (mm)									R/L	Grade
	d	f	a	b	l1	l2	r	Tmax	Dmin		
MINTR04-020004D006*	4.00	-	0.50	0.35	18.50	3.50	0.04	0.08	0.60	R	●
030004D006*	4.00	-	0.50	0.35	19.50	4.50	0.04	0.08	0.60	R	●
045005D010	4.00	-	0.90	0.70	21.00	6.00	0.05	0.10	1.00	R	●
065005D010	4.00	-	0.90	0.70	23.00	8.00	0.05	0.10	1.00	R	●
040005D020	4.00	-	1.70	1.45	20.50	5.50	0.05	0.10	2.00	R	●
090005D020	4.00	-	1.70	1.45	25.50	10.50	0.05	0.10	2.00	R	●
140005D020	4.00	-	1.70	1.45	30.50	15.50	0.05	0.10	2.00	R	●
090010D028	4.00	0.90	2.60	2.20	25.50	10.50	0.10	0.20	2.80	R	●
150010D028	4.00	0.90	2.60	2.20	31.50	16.50	0.10	0.20	2.80	R	●
190010D028	4.00	0.90	2.60	2.20	35.50	20.50	0.10	0.20	2.80	R	●
090010D040	4.00	1.50	3.50	2.90	25.50	10.50	0.10	0.30	4.00	R	●
150010D040	4.00	1.50	3.50	2.90	31.50	16.50	0.10	0.30	4.00	R	●
190010D040	4.00	1.50	3.50	2.90	35.50	20.50	0.10	0.30	4.00	R	●
230010D040	4.00	1.50	3.50	2.90	39.50	24.50	0.10	0.30	4.00	R	●
270010D040	4.00	1.50	3.50	2.90	43.50	28.50	0.10	0.30	4.00	R	●
MINTL04-090010D028	4.00	0.90	2.60	2.20	25.50	10.50	0.10	0.20	2.80	L	●
150010D028	4.00	0.90	2.60	2.20	31.50	16.50	0.10	0.20	2.80	L	●
190010D028	4.00	0.90	2.60	2.20	35.50	20.50	0.10	0.20	2.80	L	●
090010D040	4.00	1.50	3.50	2.90	25.50	10.50	0.10	0.30	4.00	L	●
150010D040	4.00	1.50	3.50	2.90	31.50	16.50	0.10	0.30	4.00	L	●
190010D040	4.00	1.50	3.50	2.90	35.50	20.50	0.10	0.30	4.00	L	●

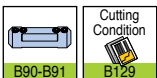

* Max D.O.C: 0.01 - 0.03, max feed 0.01mm/rev

●: Standard items

Mini carbide bars for internal turning and chamfering

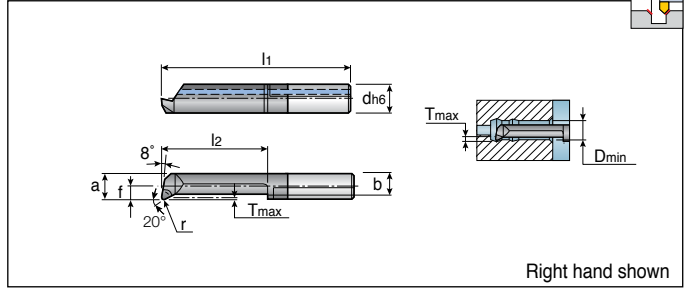

Designation	Dimension (mm)									R/L	Grade TT9030
	d	f	a	b	l ₁	l ₂	r	T _{max}	D _{min}		
MINTR07-090015D050	7.00	0.90	4.40	3.65	25.00	10.00	0.15	0.50	5.00	R	●
140015D050	7.00	0.90	4.40	3.65	30.00	15.00	0.15	0.50	5.00	R	●
190015D050	7.00	0.90	4.40	3.65	35.00	20.00	0.15	0.50	5.00	R	●
240015D050	7.00	0.90	4.40	3.65	40.00	25.00	0.15	0.50	5.00	R	●
290015D050	7.00	0.90	4.40	3.65	45.00	30.00	0.15	0.50	5.00	R	●
340015D050	7.00	0.90	4.40	3.65	50.00	35.00	0.15	0.50	5.00	R	●
140015D060	7.00	1.80	5.30	4.40	30.00	15.00	0.15	0.50	6.00	R	●
210015D060	7.00	1.80	5.30	4.40	37.00	22.00	0.15	0.50	6.00	R	●
240015D060	7.00	1.80	5.30	4.40	40.00	25.00	0.15	0.50	6.00	R	●
290015D060	7.00	1.80	5.30	4.40	45.00	30.00	0.15	0.50	6.00	R	●
340015D060	7.00	1.80	5.30	4.40	50.00	35.00	0.15	0.50	6.00	R	●
410015D060	7.00	1.80	5.30	4.40	57.00	42.00	0.15	0.50	6.00	R	●
190015D068	7.00	2.80	6.30	5.40	35.00	20.00	0.15	0.60	6.80	R	●
240015D068	7.00	2.80	6.30	5.40	40.00	25.00	0.15	0.60	6.80	R	●
290015D068	7.00	2.80	6.30	5.40	45.00	30.00	0.15	0.60	6.80	R	●
340015D070	7.00	2.80	6.30	5.40	50.00	35.00	0.15	0.60	7.00	R	●
390015D070	7.00	2.80	6.30	5.40	55.00	40.00	0.15	0.60	7.00	R	●
440015D070	7.00	2.80	6.30	5.40	60.00	45.00	0.15	0.60	7.00	R	●
490015D070	7.00	2.80	6.30	5.40	65.00	50.00	0.15	0.60	7.00	R	●
MINTL07-090015D050	7.00	0.90	4.40	3.65	25.00	10.00	0.15	0.50	5.00	L	●
140015D050	7.00	0.90	4.40	3.65	30.00	15.00	0.15	0.50	5.00	L	●
190015D050	7.00	0.90	4.40	3.65	35.00	20.00	0.15	0.50	5.00	L	●
240015D050	7.00	0.90	4.40	3.65	40.00	25.00	0.15	0.50	5.00	L	●
290015D050	7.00	0.90	4.40	3.65	45.00	30.00	0.15	0.50	5.00	L	●
140015D060	7.00	1.80	5.30	4.40	30.00	15.00	0.15	0.50	6.00	L	●
210015D060	7.00	1.80	5.30	4.40	37.00	22.00	0.15	0.50	6.00	L	●
240015D060	7.00	1.80	5.30	4.40	40.00	25.00	0.15	0.50	6.00	L	●
290015D060	7.00	1.80	5.30	4.40	45.00	30.00	0.15	0.50	6.00	L	●
190015D068	7.00	2.80	6.30	5.40	35.00	20.00	0.15	0.60	6.80	L	●
290015D068	7.00	2.80	6.30	5.40	45.00	30.00	0.15	0.60	6.80	L	●
340015D070	7.00	2.80	6.30	5.40	50.00	35.00	0.15	0.60	7.00	L	●

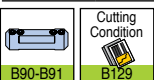

●: Standard items

MINP R 04/07



Mini carbide bars for internal turning and profiling

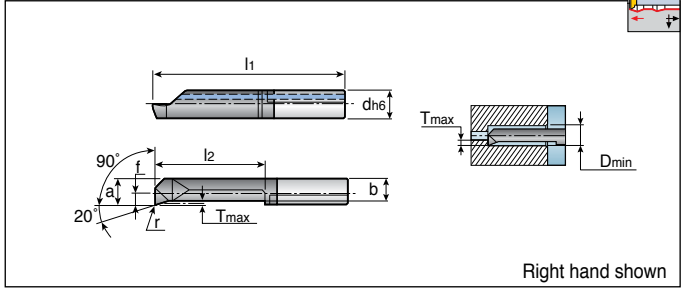

Designation	Dimension (mm)									R/L	Grade TT9030
	d	f	a	b	l ₁	l ₂	r	T _{max}	D _{min}		
MINPR04- 090010D028	4.00	0.90	2.60	2.20	25.50	10.50	0.10	0.20	2.80	R	●
150010D028	4.00	0.90	2.60	2.20	31.50	16.50	0.10	0.20	2.80	R	●
090010D040	4.00	1.50	3.50	2.90	25.50	10.50	0.10	0.30	4.00	R	●
150010D040	4.00	1.50	3.50	2.90	31.50	16.50	0.10	0.30	4.00	R	●
MINPR07- 140015D050	7.00	0.90	4.40	3.65	30.00	15.00	0.15	0.50	5.00	R	●
190015D050	7.00	0.90	4.40	3.65	35.00	20.00	0.15	0.50	5.00	R	●

●: Standard items

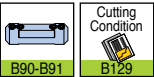

MINC R 07



Mini carbide bars for internal turning and 45° chamfering

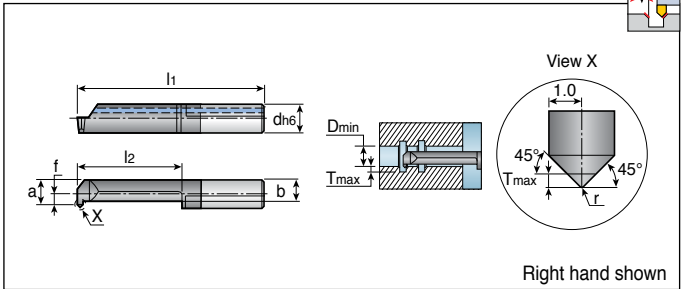

Designation	Dimension (mm)									R/L	Grade TT9030
	d	f	a	b	l ₁	l ₂	r	T _{max}	D _{min}		
MINCR07-140020D050	7.00	0.90	4.40	3.20	30.00	15.00	0.20	0.70	5.00	R	●
190020D050	7.00	0.90	4.40	3.20	35.00	20.00	0.20	0.70	5.00	R	●
190020D068	7.00	2.80	6.30	3.80	35.00	20.00	0.20	0.70	6.80	R	●

●: Standard items

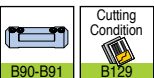

MING R/L 07



Mini carbide bars for grooving and turning

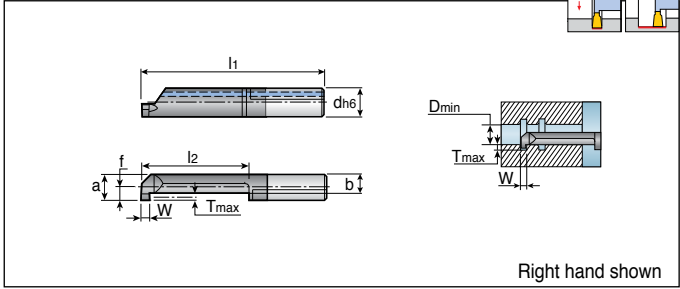

Designation	Dimension (mm)										R/L	Grade TT9030
	d	W ^{+0.05/0}	f	a	b	l1	l2	Tmax	Dmin			
MINGR07-090100D050	7.00	1.00	0.90	4.40	3.00	25.00	10.00	1.00	5.00	R	●	
140100D050	7.00	1.00	0.90	4.40	3.00	30.00	15.00	1.00	5.00	R	●	
090150D050	7.00	1.50	0.90	4.40	3.00	25.00	10.00	1.00	5.00	R	●	
140150D050	7.00	1.50	0.90	4.40	3.00	30.00	15.00	1.00	5.00	R	●	
090200D050	7.00	2.00	0.90	4.40	3.00	25.00	10.00	1.00	5.00	R	●	
190200D050	7.00	2.00	0.90	4.40	3.00	35.00	20.00	1.00	5.00	R	●	
090100D060	7.00	1.00	1.80	5.30	3.10	25.00	10.00	1.80	6.00	R	●	
140100D060	7.00	1.00	1.80	5.30	3.10	30.00	15.00	1.80	6.00	R	●	
210100D060	7.00	1.00	1.80	5.30	3.10	37.00	22.00	1.80	6.00	R	●	
290100D060	7.00	1.00	1.80	5.30	3.10	45.00	30.00	1.80	6.00	R	●	
090150D060	7.00	1.50	1.80	5.30	3.10	25.00	10.00	1.80	6.00	R	●	
140150D060	7.00	1.50	1.80	5.30	3.10	30.00	15.00	1.80	6.00	R	●	
210150D060	7.00	1.50	1.80	5.30	3.10	37.00	22.00	1.80	6.00	R	●	
240150D060	7.00	1.50	1.80	5.30	3.10	40.00	25.00	1.80	6.00	R	●	
290150D060	7.00	1.50	1.80	5.30	3.10	45.00	30.00	1.80	6.00	R	●	
090200D060	7.00	2.00	1.80	5.30	3.10	25.00	10.00	1.80	6.00	R	●	
140200D060	7.00	2.00	1.80	5.30	3.10	30.00	15.00	1.80	6.00	R	●	
210200D060	7.00	2.00	1.80	5.30	3.10	37.00	22.00	1.80	6.00	R	●	
240200D060	7.00	2.00	1.80	5.30	3.10	40.00	25.00	1.80	6.00	R	●	
290200D060	7.00	2.00	1.80	5.30	3.10	45.00	30.00	1.80	6.00	R	●	
090100D068	7.00	1.00	2.70	6.20	3.30	25.00	10.00	2.50	6.80	R	●	
140100D068	7.00	1.00	2.70	6.20	3.30	30.00	15.00	2.50	6.80	R	●	
210100D068	7.00	1.00	2.70	6.20	3.30	37.00	22.00	2.50	6.80	R	●	
090150D068	7.00	1.50	2.70	6.20	3.30	25.00	10.00	2.50	6.80	R	●	
140150D068	7.00	1.50	2.70	6.20	3.30	30.00	15.00	2.50	6.80	R	●	
210150D068	7.00	1.50	2.70	6.20	3.30	37.00	22.00	2.50	6.80	R	●	
290150D068	7.00	1.50	2.70	6.20	3.30	45.00	30.00	2.50	6.80	R	●	
090200D068	7.00	2.00	2.70	6.20	3.30	25.00	10.00	2.50	6.80	R	●	
140200D068	7.00	2.00	2.70	6.20	3.30	30.00	15.00	2.50	6.80	R	●	
210200D068	7.00	2.00	2.70	6.20	3.30	37.00	22.00	2.50	6.80	R	●	
290200D068	7.00	2.00	2.70	6.20	3.30	45.00	29.00	2.50	6.80	R	●	
MINGL07-090100D060	7.00	1.00	1.80	5.30	3.10	25.00	10.00	1.80	6.00	L	●	
090150D060	7.00	1.50	1.80	5.30	3.10	25.00	10.00	1.80	6.00	L	●	
140200D068	7.00	2.00	2.70	6.20	3.30	30.00	15.00	2.50	6.80	L	●	

●: Standard items

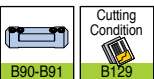

MINA R 07

TOPMICRO

Mini carbide bars for grooving along shaft

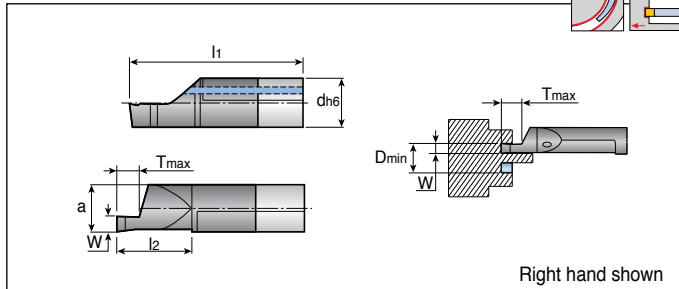

Designation	Dimension (mm)							R/L	Grade TT9030
	d	W ^{+0.05}	a	l ₁	l ₂	T _{max}	D _{min}		
MINAR07-200200D060	7.00	2.00	5.20	36.00	21.00	4.00	6.00	R	●

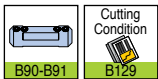

●: Standard items

MINR R 07

TOPMICRO

Mini carbide bars, full radius for internal boring and profiling

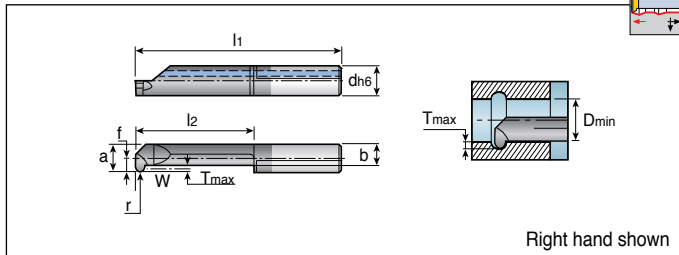

Designation	Dimension (mm)										R/L	Grade TT9030
	d	W ^{+0.05}	f	a	b	r	l ₁	l ₂	T _{max}	D _{min}		
MINRR07- 190050D050	7.00	1.00	0.90	4.40	3.10	0.50	35.00	20.00	1.00	5.00	R	●
240050D060	7.00	1.00	1.80	5.30	3.20	0.50	40.00	25.00	1.80	6.00	R	●
290050D068	7.00	1.00	2.80	6.30	3.55	0.50	45.00	30.00	2.50	6.80	R	●

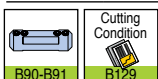

●: Standard items

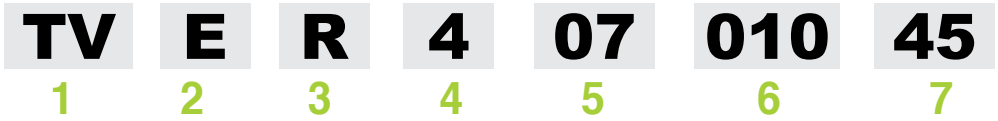

1 TaeguTec TOPCUT series

2 Application type

- E External turning
- R Reverse turning
- B Back turning
- T Threading
- P Parting

3 Hand of tool

- R Right-hand
- L Left-hand

4 Insert thickness

4 3.97mm

5 Width of insert

- 07 0.7mm
- 10 1.0mm
- 12 1.2mm
- 15 1.5mm
- 18 1.8mm
- 20 2.0mm

6 Corner radius

- 000 0mm
- 003 0.03mm
- 005 0.05mm
- 010 0.10mm
- 015 0.15mm

7 Tmax (TVPR/L only)

- 45 4.5mm
- 50 5.0mm
- 60 6.0mm

General turning

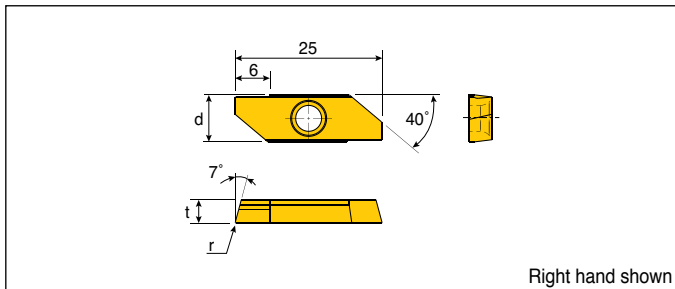

Designation	Feed (mm/rev)	ap (mm)	Dimension (mm)				Grade (TT9010)	
			d	t	r	T _{max}	R	L
TVER/L 40003	0.01-0.15	0.1-5.5	8	3.97	0.03	5.5	●	
40010	0.01-0.15	0.1-5.5	8	3.97	0.10	5.5	●	



●: Standard items

TVRR/L

Reverse turning

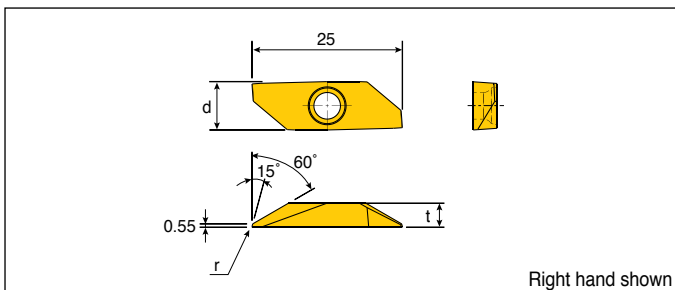

Designation	Feed (mm/rev)	ap (mm)	Dimension (mm)				Grade (TT9010)	
			d	t	r	T _{max}	R	L
TVRR/L 40003-60	0.01-0.15	0.1-5.5	8	3.97	0.03	5.5	●	
40010-60	0.01-0.15	0.1-5.5	8	3.97	0.10	5.5	●	



●: Standard items

Back turning

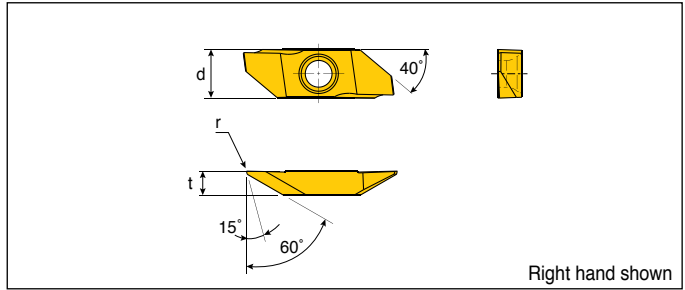

Designation	Feed (mm/rev)	ap (mm)	Dimension (mm)				Grade (TT9010)	
			d	t	r	T _{max}	R	L
TVBR/L 40003	0.01-0.15	0.1-5.5	8	3.97	0.03	5.5	●	●
40005	0.01-0.15	0.1-5.5	8	3.97	0.05	5.5	●	●
40010	0.01-0.15	0.1-5.5	8	3.97	0.10	5.5	●	●
40015	0.01-0.15	0.1-5.5	8	3.97	0.15	5.5	●	●
40005-H⁽¹⁾	0.01-0.15	0.1-5.5	8	3.97	0.05	5.5	●	●
40010-H⁽¹⁾	0.01-0.15	0.1-5.5	8	3.97	0.10	5.5	●	●
40015-H⁽¹⁾	0.01-0.15	0.1-5.5	8	3.97	0.15	5.5	●	●



● ⁽¹⁾ With honed edges

●: Standard items

TVTR/L

Threading

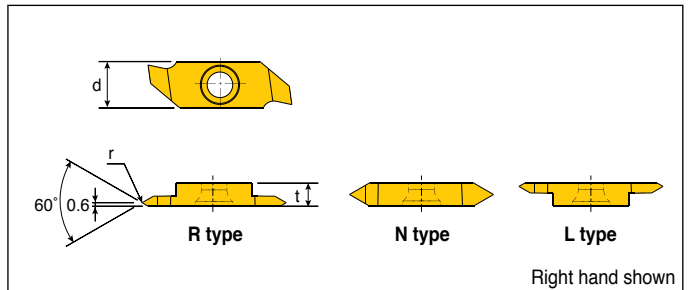

Designation	Dimension (mm)			Grade (TT9010)	
	d	t	r	R	L
TVTR/L 41203-R	8	3.97	0.03	●	
40003-N	8	3.97	0.03	●	
41203-L	8	3.97	0.03		



● TVTR 41203-R/L → pitch range: 0.5 - 1.0mm
 ● TVTR 40003-N → pitch range: 0.5 - 2.0mm

●: Standard items

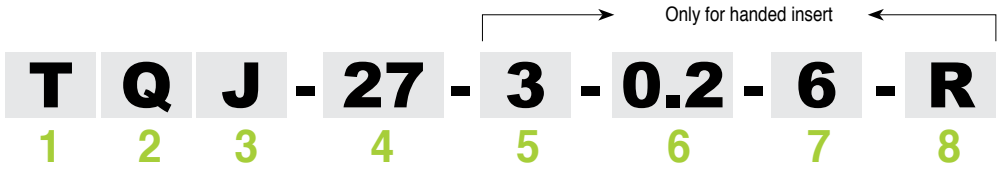

1 TaeguTec

2 QUADRUSH

3 Chip breaker type

C	J	S
For medium	For light	For light & tailor made

4 Circular circumference of the insert

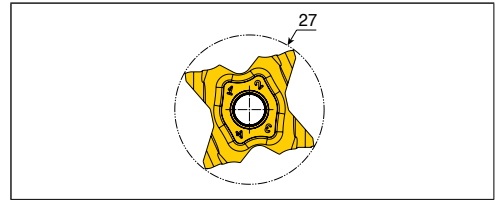

5 Width of insert

	<p>1.00 = 1.0 mm</p> <p>1.50 = 1.5mm</p> <p>2.53 = 2.53mm</p> <p>3.18 = 3.18mm</p>
--	--

6 Corner radius

	<p>0.10 = 0.1mm</p> <p>0.20 = 0.2mm</p> <p>0.30 = 0.3mm</p> <p>0.40 = 0.4mm</p>
--	---

7 Lead angle

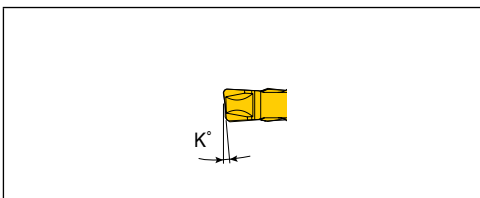

8 Hand of insert

L	R
Left-hand	Right-hand

Precision grooving, parting and recessing insert

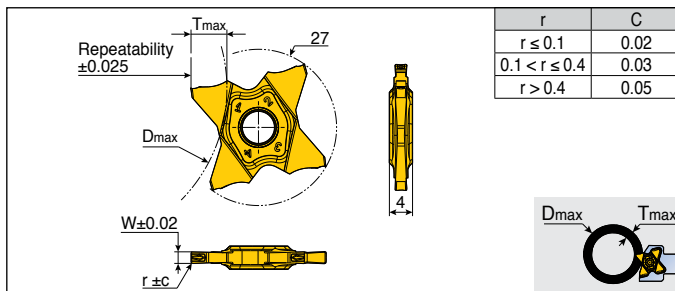

r	C
$r \leq 0.1$	0.02
$0.1 < r \leq 0.4$	0.03
$r > 0.4$	0.05

Designation	Feed (mm/rev)	W±0.02	r	Tmax	Dmax												Grade
					T ≤ 3.0	T ≤ 3.5	T ≤ 4.0	T ≤ 4.5	T ≤ 5.0	T ≤ 5.5	T ≤ 5.7	T ≤ 6.0	T ≤ 6.2	T ≤ 6.4	TT9080		
TQJ 27-0.50-0.00	0.02-0.04	0.50	0.00	1.0	-	-	-	-	-	-	-	-	-	-	-	-	●
27-0.50-0.04	0.02-0.04	0.50	0.04	2.5	-	-	-	-	-	-	-	-	-	-	-	-	●
27-0.75-0.10	0.02-0.05	0.75	0.10	2.5	-	-	-	-	-	-	-	-	-	-	-	-	●
27-0.80-0.00	0.02-0.05	0.80	0.00	1.6	-	-	-	-	-	-	-	-	-	-	-	-	●
27-1.00-0.06	0.03-0.07	1.00	0.06	3.5	N.L.	600	-	-	-	-	-	-	-	-	-	-	●
27-1.00-0.10	0.03-0.07	1.00	0.10	3.5	N.L.	600	-	-	-	-	-	-	-	-	-	-	●
27-1.04-0.00	0.03-0.07	1.04	0.00	2.0	-	-	-	-	-	-	-	-	-	-	-	-	●
27-1.20-0.00	0.03-0.07	1.20	0.00	2.0	-	-	-	-	-	-	-	-	-	-	-	-	●
27-1.25-0.10	0.03-0.07	1.25	0.10	3.5	N.L.	600	-	-	-	-	-	-	-	-	-	-	●
27-1.25-0.20	0.03-0.07	1.25	0.20	3.5	N.L.	600	-	-	-	-	-	-	-	-	-	-	●
27-1.40-0.00	0.03-0.08	1.40	0.00	2.0	-	-	-	-	-	-	-	-	-	-	-	-	●
27-1.47-0.00	0.03-0.08	1.47	0.00	2.5	-	-	-	-	-	-	-	-	-	-	-	-	●
27-1.50-0.10	0.03-0.08	1.50	0.10	5.7	N.L.	600	280	180	130	50	35	-	-	-	-	-	●
27-1.50-0.20	0.03-0.08	1.50	0.20	5.7	N.L.	600	280	180	130	50	35	-	-	-	-	-	●
27-1.57-0.10	0.03-0.08	1.57	0.10	3.0	N.L.	-	-	-	-	-	-	-	-	-	-	-	●
27-1.57-0.15	0.03-0.08	1.57	0.15	3.0	N.L.	-	-	-	-	-	-	-	-	-	-	-	●
27-1.70-0.10	0.03-0.08	1.70	0.10	3.0	N.L.	-	-	-	-	-	-	-	-	-	-	-	●
27-1.75-0.10	0.03-0.08	1.75	0.10	3.0	N.L.	-	-	-	-	-	-	-	-	-	-	-	●
27-1.75-0.20	0.03-0.08	1.75	0.20	3.0	N.L.	-	-	-	-	-	-	-	-	-	-	-	●
27-1.78-0.18	0.04-0.10	1.78	0.18	3.0	N.L.	-	-	-	-	-	-	-	-	-	-	-	●
27-1.85-0.20	0.04-0.10	1.85	0.20	3.0	N.L.	-	-	-	-	-	-	-	-	-	-	-	●
27-1.96-0.15	0.04-0.10	1.96	0.15	3.0	N.L.	-	-	-	-	-	-	-	-	-	-	-	●
27-2.00-0.10	0.04-0.10	2.00	0.10	6.4	N.L.	600	280	180	130	105	85	60	50	30	-	-	●
27-2.00-0.20	0.04-0.10	2.00	0.20	6.4	N.L.	600	280	180	130	105	85	60	50	30	-	-	●
27-2.22-0.15	0.04-0.10	2.22	0.15	3.5	N.L.	600	-	-	-	-	-	-	-	-	-	-	●
27-2.30-0.20	0.04-0.10	2.30	0.20	3.5	N.L.	600	-	-	-	-	-	-	-	-	-	-	●
27-2.39-0.15	0.04-0.10	2.39	0.15	5.7	N.L.	600	280	180	130	50	35	-	-	-	-	-	●
27-2.47-0.20	0.04-0.10	2.47	0.20	5.7	N.L.	600	280	180	130	50	35	-	-	-	-	-	●
27-2.50-0.10	0.04-0.10	2.50	0.10	5.7	N.L.	600	280	180	130	50	35	-	-	-	-	-	●
27-2.50-0.30	0.05-0.12	2.50	0.30	5.7	N.L.	600	280	180	130	50	35	-	-	-	-	-	●
27-2.70-0.10	0.05-0.12	2.70	0.10	6.2	N.L.	600	280	180	135	105	95	85	78	-	-	-	●
27-2.87-0.20	0.05-0.12	2.87	0.20	6.2	N.L.	600	280	180	135	105	95	85	78	-	-	-	●



• N.L. = No limit

●: Standard items

TQJ 27

QUAD-RUSH

Precision grooving, parting and recessing insert

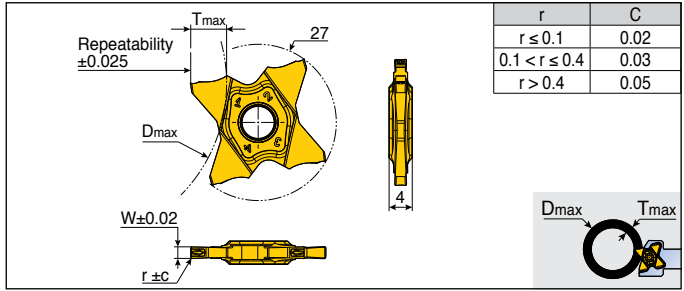

Designation	Feed (mm/rev)	W±0.02	r	Tmax	Dmax										Grade
					T ≤ 3.0	T ≤ 3.5	T ≤ 4.0	T ≤ 4.5	T ≤ 5.0	T ≤ 5.5	T ≤ 5.7	T ≤ 6.0	T ≤ 6.2	T ≤ 6.4	
TQJ 27-3.00-0.00	0.05-0.12	3.00	0.00	6.4	N.L.	600	280	180	135	105	95	85	78	55	●
27-3.00-0.20	0.05-0.12	3.00	0.20	6.4	N.L.	600	280	180	135	105	95	85	78	55	●
27-3.00-0.30	0.05-0.12	3.00	0.30	6.4	N.L.	600	280	180	135	105	95	85	78	55	●
27-3.00-0.40	0.05-0.12	3.00	0.40	6.4	N.L.	600	280	180	135	105	95	85	78	55	●
27-3.15-0.15	0.05-0.12	3.15	0.15	6.4	N.L.	600	280	180	135	105	95	85	78	68	●
27-3.18-0.20	0.05-0.12	3.18	0.20	6.4	N.L.	600	280	180	135	105	95	85	78	68	●



● N.L. = No limit

●: Standard items

TQJ 27

QUAD-RUSH

Parting insert

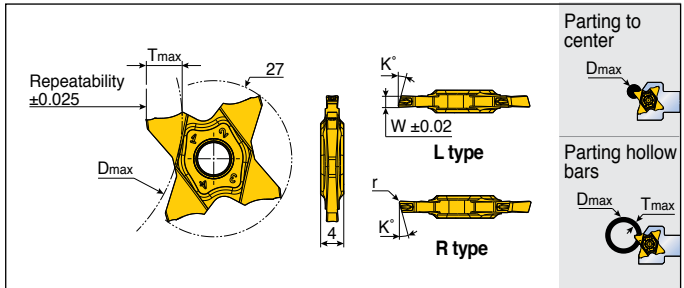

Designation	Feed (mm/rev)	W±0.02	r	K°	Parting to center		Parting hollow bars		Grade
					Dmax	Tmax	Dmax	Tmax	
TQJ 27-1.00-15R/L	0.02-0.06	1.00	0.06	15	7.0	3.5	600	●	
27-1.50-6R/L	0.02-0.06	1.50	0.06	6	12.0	5.7	35	●	
27-1.50-15R/L	0.02-0.06	1.50	0.06	15	12.0	5.7	35	●	
27-2.00-6R/L	0.03-0.08	2.00	0.10	6	13.0	6.4	30	●	
27-2.00-15R/L	0.03-0.08	2.00	0.10	15	13.0	6.4	30	●	



●: Standard items

Parting and grooving insert

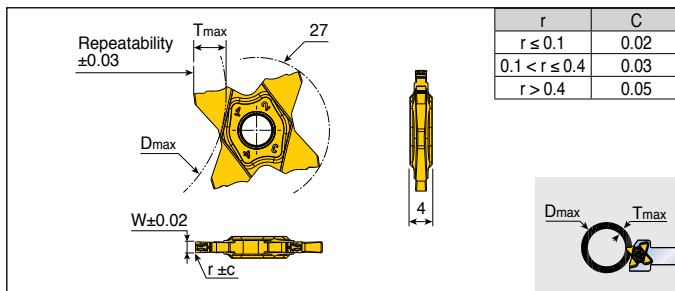

r	C
$r \leq 0.1$	0.02
$0.1 < r \leq 0.4$	0.03
$r > 0.4$	0.05

Designation	Feed (mm/rev)	W±0.02	r	T _{max}	D _{max}											Grade
					T ≤ 3.0	T ≤ 3.5	T ≤ 4.0	T ≤ 4.5	T ≤ 5.0	T ≤ 5.5	T ≤ 5.7	T ≤ 6.0	T ≤ 6.2	T ≤ 6.4	T ≤ 6.5	
TQC 27-1.50-0.10	0.05-0.08	1.50	0.10	5.7	N.L.	600	280	180	130	50	35	-	-	-	-	●
27-1.50-0.20	0.05-0.06	1.50	0.20	5.7	N.L.	600	280	180	130	50	35	-	-	-	-	●
27-1.57-0.15	0.05-0.08	1.57	0.15	3.0	N.L.	-	-	-	-	-	-	-	-	-	-	●
27-1.70-0.10	0.05-0.09	1.70	0.10	3.0	N.L.	-	-	-	-	-	-	-	-	-	-	●
27-1.75-0.10	0.05-0.10	1.75	0.10	3.0	N.L.	-	-	-	-	-	-	-	-	-	-	●
27-1.75-0.20	0.05-0.09	1.75	0.20	3.0	N.L.	-	-	-	-	-	-	-	-	-	-	●
27-1.78-0.18	0.05-0.11	1.78	0.18	3.0	N.L.	-	-	-	-	-	-	-	-	-	-	●
27-1.85-0.20	0.05-0.11	1.85	0.20	3.0	N.L.	-	-	-	-	-	-	-	-	-	-	●
27-1.96-0.15	0.05-0.11	1.96	0.15	3.0	N.L.	-	-	-	-	-	-	-	-	-	-	●
27-2.00-0.10	0.05-0.17	2.00	0.10	6.4	N.L.	600	280	180	130	105	85	60	50	30	-	●
27-2.00-0.20	0.05-0.15	2.00	0.20	6.4	N.L.	600	280	180	130	105	85	60	50	30	-	●
27-2.22-0.15	0.05-0.15	2.22	0.15	3.5	N.L.	600	-	-	-	-	-	-	-	-	-	●
27-2.30-0.20	0.05-0.16	2.30	0.20	3.5	N.L.	600	-	-	-	-	-	-	-	-	-	●
27-2.39-0.15	0.05-0.16	2.39	0.15	5.7	N.L.	600	280	180	130	50	35	-	-	-	-	●
27-2.47-0.20	0.05-0.19	2.47	0.20	5.7	N.L.	600	280	180	130	50	35	-	-	-	-	●
27-2.50-0.10	0.05-0.20	2.50	0.10	5.7	N.L.	600	280	180	130	50	35	-	-	-	-	●
27-2.50-0.30	0.05-0.17	2.50	0.30	5.7	N.L.	600	280	180	130	50	35	-	-	-	-	●
27-2.70-0.10	0.05-0.19	2.70	0.10	6.2	N.L.	600	280	180	135	105	95	85	78	-	-	●
27-2.87-0.20	0.05-0.19	2.87	0.20	6.2	N.L.	600	280	180	135	105	95	85	78	-	-	●
27-3.00-0.00	0.05-0.11	3.00	0	6.4	N.L.	600	280	180	135	105	95	85	78	55	-	●
27-3.00-0.20	0.06-0.23	3.00	0.20	6.4	N.L.	600	280	180	135	105	95	85	78	55	-	●
27-3.00-0.30	0.06-0.25	3.00	0.30	6.4	N.L.	600	280	180	135	105	95	85	78	55	-	●
27-3.00-0.40	0.06-0.25	3.00	0.40	6.4	N.L.	600	280	180	135	105	95	85	78	55	-	●
27-3.15-0.15	0.06-0.21	3.15	0.15	6.4	N.L.	600	280	180	135	105	95	85	78	68	-	●
27-3.18-0.20	0.06-0.23	3.18	0.20	6.4	N.L.	600	280	180	135	105	95	85	78	68	-	●
27-3.30-0.10	0.06-0.23	3.30	0.10	6.5	N.L.	600	280	180	135	105	85	65	50	40	35	●
27-3.48-0.20	0.06-0.23	3.48	0.20	6.5	N.L.	600	280	180	135	105	85	65	50	40	35	●
27-3.56-0.20	0.06-0.23	3.56	0.20	6.5	N.L.	600	280	180	135	105	85	65	55	40	35	●
27-3.74-0.20	0.06-0.23	3.74	0.20	6.5	N.L.	600	280	180	135	105	85	65	55	40	35	●
27-3.98-0.20	0.07-0.30	3.98	0.20	6.5	N.L.	600	280	180	135	105	95	85	78	40	45	●
27-4.00-0.30	0.07-0.30	4.00	0.30	6.5	N.L.	600	280	180	135	105	95	85	78	40	45	●
27-4.00-0.40	0.07-0.30	4.00	0.40	6.5	N.L.	600	280	180	135	105	95	85	78	40	45	●
27-4.00-0.80	0.07-0.30	4.00	0.80	6.5	N.L.	600	280	180	135	105	95	85	78	40	45	●
27-4.15-0.15	0.07-0.30	4.15	0.15	6.5	N.L.	600	280	180	135	105	95	85	78	40	45	●
27-4.23-0.10	0.07-0.30	4.23	0.10	6.5	N.L.	600	280	180	135	105	95	85	78	55	65	●



● N.L. = No limit

● Standard items

TQC 27

QUAD-RUSH

Parting insert

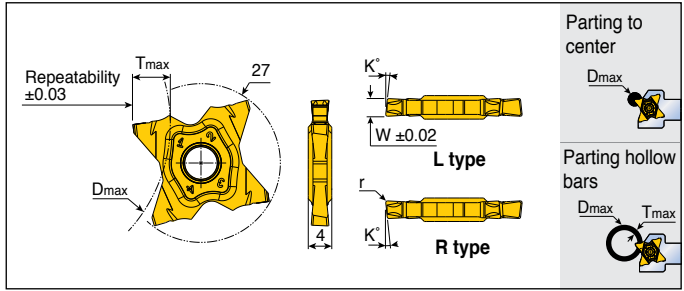

Designation	Feed (mm/rev)	W±0.02	r	K°	Parting to center		Parting hollow bars		Grade
					D _{max}	T _{max}	D _{max}	T _{max}	
TQC 27-1.50-6R/L	0.03-0.07	1.50	0.06	6	12.0	5.7	35	TT9080	●
27-1.50-15R/L	0.03-0.07	1.50	0.06	15	12.0	5.7	35	TT9080	●
27-2.00-6R/L	0.04-0.14	2.00	0.10	6	13.0	6.4	30	TT9080	●
27-2.00-15R/L	0.04-0.14	2.00	0.10	15	13.0	6.4	30	TT9080	●



●: Standard items

TQC 27

QUAD-RUSH

Full radius

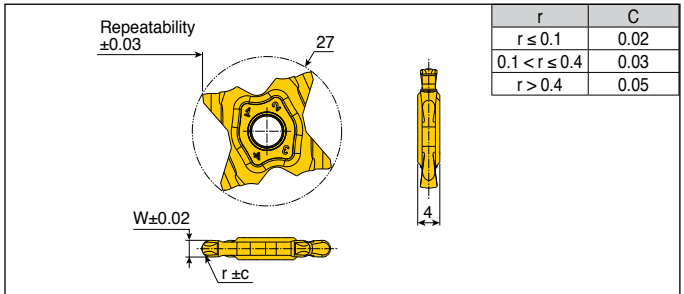

Designation	Feed (mm/rev)	W±0.02	r	T _{max}	D _{max}											Grade	
					T ≤ 3.0	T ≤ 3.5	T ≤ 4.0	T ≤ 4.5	T ≤ 5.0	T ≤ 5.5	T ≤ 5.7	T ≤ 6.0	T ≤ 6.2	T ≤ 6.4	TT9080		
TQC 27-1.57-0.79	0.05-0.09	1.57	0.79	3.0	N.L.	-	-	-	-	-	-	-	-	-	-	-	●
27-2.00-1.00	0.05-0.13	2.00	1.00	3.5	N.L.	600	-	-	-	-	-	-	-	-	-	-	●
27-2.39-1.20	0.06-0.17	2.39	1.20	5.7	N.L.	600	280	180	130	50	35	-	-	-	-	-	●
27-3.00-1.50	0.06-0.20	3.00	1.50	6.4	N.L.	600	280	180	135	105	95	85	78	55	-	-	●



● N.L. = No limit

●: Standard items

TQS 27-MT

QUAD-RUSH

Partial profile 60°

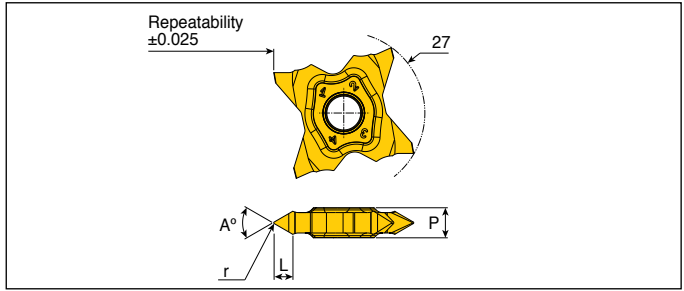

Designation	r	A°	P	L	Pitch min. (mm)	TPI max.	Grade
							TT9080
TQS 27-4MT-0.05	0.05	60	4	2.8	0.45	56	●
27-4MT-0.14	0.14	60	4	2.7	1.11	23	●
27-5MT-0.15	0.15	60	5	3.1	1.25	20	●
27-5MT-0.20	0.20	60	5	3.1	1.63	16	●
27-6MT-0.25	0.25	60	6	3.6	1.94	13	●



- Pitch max=0.175XD, TPI min=5.7/D
- D: Diameter of thread
- TPI: Thread / Inch

●: Standard items

TQS 27-WT

QUAD-RUSH

Partial profile 55°

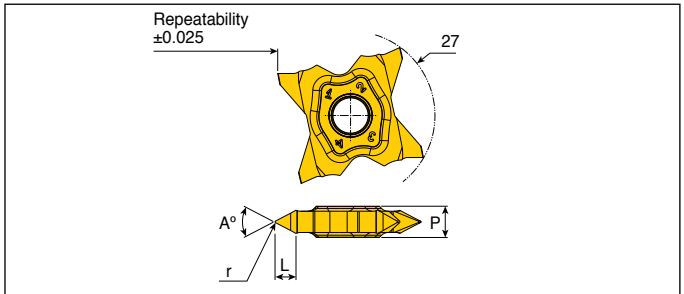

Designation	r	A°	P	L	TPI max.	TPI min.	Grade
							TT9080
TQS 27-4WT-0.05	0.05	55	4	2.9	54	6.4 / D	●
27-5WT-0.15	0.15	55	5	3.3	19	6.4 / D	●
27-6WT-0.25	0.25	55	6	3.9	12	6.4 / D	●



- D: Diameter of thread
- TPI: Thread / Inch

●: Standard items

TQS 27-ISO

ISO metric full profile, external threading

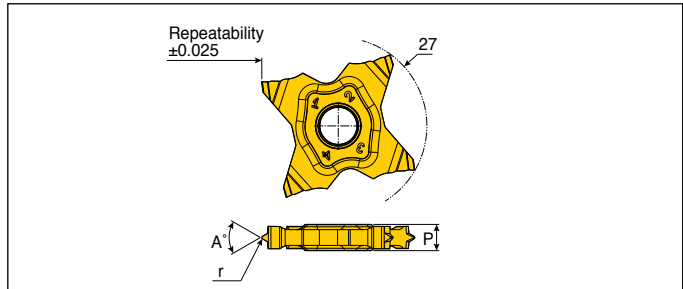

Designation	r	A°	P	Pitch	Grade
					TT9080
TQS 27-0.5-ISO	0.08	60	4	0.50	●
27-0.75-ISO	0.11	60	4	0.75	●
27-0.8-ISO	0.12	60	4	0.80	●
27-1.0-ISO	0.14	60	4	1.00	●
27-1.25-ISO	0.18	60	4	1.25	●
27-1.5-ISO	0.22	60	4	1.50	●
27-1.75-ISO	0.25	60	4	1.75	●
27-2.0-ISO	0.28	60	4	2.00	●



●: Standard items

TQS 27-UN

American UN (UNC, UNF, UNEF) full profile, external threading

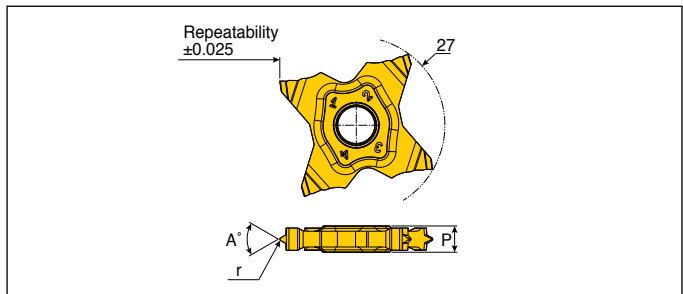

Designation	r	A°	P	TPI	Grade
					TT9080
TQS 27-24-UN	0.13	60	4	24	●
27-20-UN	0.16	60	4	20	●
27-18-UN	0.16	60	4	18	●
27-16-UN	0.21	60	4	16	●
27-14-UN	0.23	60	4	14	●
27-12-UN	0.27	60	4	12	●



● TPI: Thread / Inch

●: Standard items

TDIT **3.20** - **0.00** - **0.25** - - **TT8020**

1 2 3 4 5 6

1 Main style of insert

T type: Chip breaker
G type: Non-chip breaker

2 Insert width

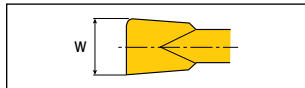

3 Corner radius

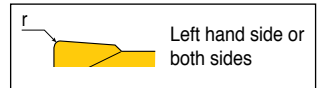

4 Corner radius

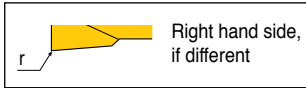

5 Additional codes

6 Grades

Parting & Grooving	Turning & Grooving
<p>TDJ / TDC</p> <p>TSJ / TSC</p>	<p>TDT TDA TDG</p> <p>TDIT TDFT</p> <p>Internal Face</p>

Special profile inserts



Tailor-made inserts are available upon request.

Shape	Designation	Remarks
	TDT 4.00-0.50	Symmetrical type
	TDIT 3.20-0.00-0.25	Non-symmetrical type
	TDT 3.30-1.65	Full-R type
	TDT 4.00-0.30-5RA	L: Chamfer on left hand side R: Chamfer on right hand side
	TDT 3.10-0.10-15LA	
	TDG 5.28-1.20-R25A	
	TDT 5.28-1.20-L25A	

Shape	Designation	Remarks
	TDG 4.40-1.82-29A	L: Chamfer on left hand side R: Chamfer on right hand side
	TDT 4.40-1.50-30A	
	TDT 5.28-2.05-45R25L	
	TDG 4.40-0.15-60A	
	TDG 5.40-0.10-30R50L	
	TDT 3.90-4.00	
	TDT 1.90-T3.5C	
	TDT 1.90-0.30-4.20T	

Shape	Designation	Remarks
	<p>TDG 1.98-T4.5C</p>	
	<p>TDFT 3.80E-0.25</p>	
	<p>TDIT 2.60-1.30</p>	
<p>The others</p>	<p>Available upon customer's request</p>	

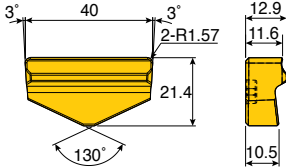
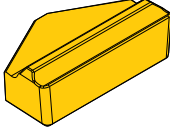
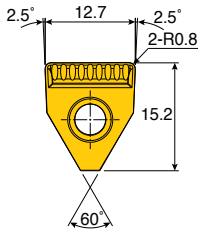
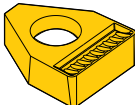
Designation	Dimension (mm)	Remarks
XNMR 401416-HD		
XNGT 332-GV		

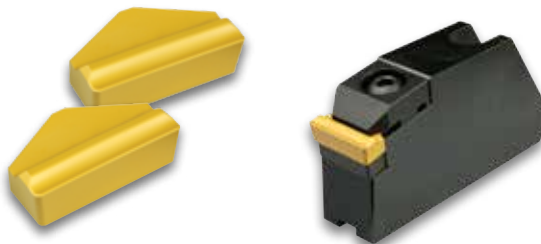

Shape	Designation	Grade	Pitch	Z
	B ZT 2706035-N4	Carbide	3.56	4
	B ZT 2706043-N3	Carbide	3.56	3
	B ZT 22-5.76-0.425-N3	Carbide	3.56	3
	B ZT 13.5-5.76-N3	Carbide	3.56	3

Shape	Designation	Grade	Pitch	Z
	B ZT 22-5.76-N3-A20	Carbide	3.56	3
	B ZT1215-NO	Carbide	2.34	5
	B ZT 5030-ITX	Ceramic	3.56	6
	B ZT 22-5.76-N3-CE-P	Ceramic	3.56	3
	D INMN 09A111	Ceramic	3.56	3

► Specific dimensions

External holder

Right handed shown

Internal holder

Right handed shown

Facing holder

Right handed shown

External holder

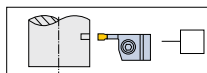

Facing holder

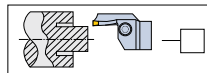
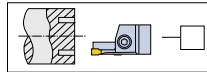

RN type

Internal holder

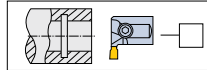

Holder handed

- Right handed
- Light handed

Insert

- Grade: _____
- Chip breaker type: _____

Quantity

- _____ pcs

Workpieces

- Part: _____
- Material: _____
- Hardness: _____

Comment

■ Customer: _____ ■ Contact: _____
 ■ Address : _____
 ■ Telephone : _____ ■ Fax : _____
 ■ E-mail : _____

Recommended Cutting Conditions

Parting and grooving

ISO	Material	Condition	Tensile strength (N/mm ²)	Hardness HB	Material No.	Cutting speed Vc(m/min)			
						TT9080 TT7220	TT8020	K10	
P	Non-alloy steel, cast steel, free cutting steel	<0.25%C	Annealed	420	125	1	140-250	80-120	
		>=0.25%C	Annealed	650	190	2	130-220	80-110	
		<0.55%C	Quenched and tempered	850	250	3	90-200	70-90	
		>=0.55%C	Annealed	750	220	4	100-220	70-100	
			Quenched and tempered	1000	300	5	70-170	40-70	
	Low alloy steel and cast steel (Less than 5% of alloying elements)	Quenched and tempered	600	200	6	90-120	70-100		
			930	275	7	80-170	50-70		
			1000	300	8	70-130	40-60		
			1200	350	9	50-120	30-50		
	High alloy steel, cast steel and tool steel	Annealed	680	200	10	60-140	50-80		
Quenched and tempered		1100	325	11	50-70	30-60			
M	Stainless steel and cast steel	Ferritic / martensitic	680	200	12	70-170	80-120		
		Martensitic	820	240	13	60-150	60-90		
		Austenitic	600	180	14	90-180	60-90		
K	Gray cast iron (GG)	Ferritic		160	15	100-230		60-80	
		Pearlitic		250	16	90-180		50-70	
	Cast iron nodular (GGG)	Ferritic		180	17	190-300		70-100	
		Pearlitic		260	18	120-220		70-90	
	Malleable cast iron	Ferritic		130	19	120-250		60-85	
Pearlitic			230	20	100-210		45-75		
N	Aluminum - Wrought alloy	Not cureable		60	21				
		Cured		100	22				
	Aluminum-cast, alloyed	<=12% Si	Not cureable		75	23			
		Cured		90	24				
	>12% Si	High temp.		130	25				
	Copper alloys	>1% Pb	Free cutting		110	26			
		Brass			90	27			
		Electrolytic copper			100	28			
Non-metallic	Duroplastics, fiber plastics				29				
	Hard rubber				30				
S	High temp. alloys	Fe based	Annealed		200	31	40-70		35-50
			Cured		280	32	30-50		25-40
		Ni or Co based	Annealed		250	33	30-40		20-30
			Cured		350	34	15-25		15-20
	Titanium, Ti alloys	Cast		320	35	15-30		15-20	
			Rm 400		36	90-190		150-200	
H	Hardened steel	Hardened		55HRC	38				
		Hardened		60HRC	39				
H	Chilled cast iron	Cast		400	40				
	Cast iron nodular	Hardened		55HRC	41				

• For more information of material groups, see the materials & grades "material conversion table"

■ Steel
 ■ Stainless steel
 ■ Cast iron
 ■ Nonferrous
 ■ High temp. alloys
 ■ Hardened steel

Recommended Cutting Conditions

Turning and grooving

ISO	Material	Condition	Tensile strength (N/mm ²)	Hardness HB	Material No.	Groove-turn, profiling, undercutting cutting speed Vc(m/min)		
						KP300	TB650	
P	Non-alloy steel, cast steel, free cutting steel	<0.25%C	Annealed	420	125	1		
		≥0.25%C	Annealed	650	190	2		
		<0.55%C	Quenched and tempered	850	250	3		
		≥0.55%C	Annealed	750	220	4		
			Quenched and tempered	1000	300	5		
	Low alloy steel and cast steel (Less than 5% of alloying elements)		Annealed		600	200	6	
					930	275	7	
			Quenched and tempered		1000	300	8	
					1200	350	9	
	High alloy steel, cast steel and tool steel		Annealed	680	200	10		
			Quenched and tempered	1100	325	11		
M	Stainless steel and cast steel	Ferritic / martensitic	680	200	12			
		Martensitic	820	240	13			
		Austenitic	600	180	14			
K	Gray cast iron (GG)	Ferritic		160	15			
		Pearlitic		250	16			
	Cast iron nodular (GGG)	Ferritic		180	17			
		Pearlitic		260	18			
	Malleable cast iron	Ferritic		130	19			
Pearlitic			230	20				
N	Aluminum - Wrought alloy	Not cureable		60	21	150-2500		
		Cured		100	22	150-2500		
	Aluminum-cast, alloyed	≤12% Si	Not cureable		75	23	150-2500	
			Cured		90	24	150-2500	
		>12% Si	High temp.		130	25	330-800	
	Copper alloys	>1% Pb	Free cutting		110	26		
			Brass		90	27	330-800	
			Electrolitic copper		100	28	190-400	
	Non-metallic		Duroplastics, fiber plastics			29		
			Hard rubber			30		
S	High temp. alloys	Fe based	Annealed		200	31		
			Cured		280	32		
		Ni or Co based	Annealed		250	33		
			Cured		350	34		
			Cast		320	35		
	Titanium, Ti alloys			Rm 400		36		
			Alpha+beta alloys cured	Rm 1050		37		
H	Hardened steel	Hardened		55HRC	38			
				60HRC	39	90-100		
	Chilled cast iron	Cast		400	40	180-200		
	Cast iron nodular	Hardened		55HRC	41	90-110		

• For more information of material groups, see the materials & grades "material conversion table"

■ Steel
 ■ Stainless steel
 ■ Cast iron
 ■ Nonferrous
 ■ High temp. alloys
 ■ Hardened steel

Recommended Cutting Conditions

Turning and grooving

Groove-turn, profiling, undercutting cutting speed Vc(m/min)						Internal grooving, face grooving cutting speed Vc(m/min)				
CT3000	TT7505	TT6080	TT9080 TT7220	TT8020	K10	TT7505	TT6080	TT9080 TT7220	TT8020	K10
100-210			100-200	100-180				100-150	80-110	
100-200			100-180	100-150				60-100	60-90	
80-180			80-160	80-130						
80-180			80-160	80-130				60-110	50-90	
70-150			70-130	70-120						
100-180			100-160	10-150				60-110	40-70	
90-180			80-160	80-150				70-110	40-60	
80-170			80-150	80-130						
80-150			80-130	80-120				60-90	30-50	
90-130			90-130	90-110				60-90	30-50	
50-80			50-80	50-70				50-80	30-40	
80-170			80-170	80-170				50-130	40-80	
80-150			80-150	80-150						
80-170			80-170	80-170				40-130	30-80	
	150-270	110-250			70-100	90-140	70-120			40-60
	120-170	90-140			50-90	80-120	60-100			40-60
	150-250	120-230			70-100	90-130	70-110			40-60
	120-200	90-180			60-90	80-110	60-90			30-50
	120-200	90-180			60-120	80-130	60-110			20-40
	100-180	80-150			50-80	60-100	50-90			20-40
					300-800					100-300
					230-310					100-300
					280-830					100-300
					200-510					100-300
					130-300					80-200
					120-200					80-150
					90-150					60-100
			30-50	20-30	30-40			20-40	20-30	
			20-40	15-20	20-40			15-30	15-20	
			20-30	15-20	20-30			15-20	15-20	
			15-20	15-20	15-20			15-20	15-20	
			15-20	15-20	15-20			15-20	15-20	
			130-170	80-100	100-130			90-120	60-80	
			40-70	15-30	20-50			20-50	15-30	
	30-50				20-40	15-25				15-20
	30-50				20-30	15-25				15-20
	30-50				20-50	15-25				15-25
	30-50				20-40	15-25				15-25

Recommended Cutting Conditions

QUAD-RUSH

QUADRUSH

ISO	Material	Condition	Tensile strength (N/mm ²)	Hardness HB	Material No.	Cutting speed Vc(m/min)		
						TT9080		
P	Non-alloy steel, cast steel, free cutting steel	<0.25%C	Annealed	420	125	1	110-200	
		≥0.25%C	Annealed	650	190	2	100-180	
		<0.55%C	Quenched and tempered	850	250	3	70-160	
		≥0.55%C	Annealed	750	220	4	80-180	
			Quenched and tempered	1000	300	5	60-140	
	Low alloy steel and cast steel (Less than 5% of alloying elements)		Annealed		600	200	6	80-180
					930	275	7	70-140
			Quenched and tempered		1000	300	8	60-110
					1200	350	9	40-100
	High alloy steel, cast steel and tool steel		Annealed	680	200	10	50-110	
			Quenched and tempered	1100	325	11	40-100	
M	Stainless steel and cast steel	Ferritic / martensitic	680	200	12	60-140		
		Martensitic	820	240	13	120-180		
		Austenitic	600	180	14	70-140		
K	Gray cast iron (GG)	Ferritic		160	15	120-180		
		Pearlitic		250	16	70-140		
	Cast iron nodular (GGG)	Ferritic		180	17	70-130		
		Pearlitic		260	18	60-115		
	Malleable cast iron	Ferritic		130	19	60-70		
	Pearlitic		230	20	80-170			
N	Aluminum - Wrought alloy	Not cureable		60	21	100-365		
		Cured		100	22	80-220		
	Aluminum-cast, alloyed	≤12% Si	Not cureable		75	23	200-400	
			Cured		90	24	200-280	
		>12% Si	High temp.		130	25	200-280	
	Copper alloys	>1% Pb	Free cutting		110	26	80-255	
			Brass		90	27	80-255	
	Non-metallic		Duroplastics, fiber plastics			29	80-250	
			Hard rubber			30	80-250	
S	High temp. alloys	Fe based	Annealed		200	31	30-60	
			Cured		280	32	25-40	
		Ni or Co based	Annealed		250	33	25-35	
			Cured		350	34	15-25	
			Cast		320	35	15-30	
	Titanium, Ti alloys		Rm 400		36	70-150		
		Alpha+beta alloys cured	Rm 1050		37	25-50		
H	Hardened steel	Hardened		55HRC	38	45-60		
		Hardened		60HRC	39	45-60		
	Chilled cast iron	Cast		400	40	45-60		
	Cast iron nodular	Hardened		55HRC	41	45-60		

• For more information of material groups, see the materials & grades "material conversion table"

■ Steel
 ■ Stainless steel
 ■ Cast iron
 ■ Nonferrous
 ■ High temp. alloys
 ■ Hardened steel

• **Feed rate:** Neutral: 0.05-0.18 mm/rev, Handed: Reduce 20% feed rate

Recommended Cutting Conditions

Ceramic T-CLAMP ULTRA PLUS insert

Material		Grooving	Turning
P	High hardened steel	Not recommended	250-350
			0.08-0.20
K	Cast iron	600-800	600-800
		0.1-0.2	0.1-0.24

• Above condition is adapted to TDT 4E-0.4T CE AB30

TOPMICRO

Cutting speed Vc(m/min)	Feed (mm/rev)		
	Turning / Back turning	Grooving	Face grooving
P 30-150	0.01-0.08	0.01-0.05	0.01-0.04
M 30-130			
K 30-150			
N 50-200			
S 10-50			

► Selection of chip breakers

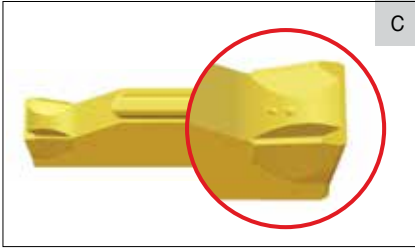

- For hard materials and tough applications
- For general applications on steel, alloy steel and stainless steel
- Medium-to-high feeds

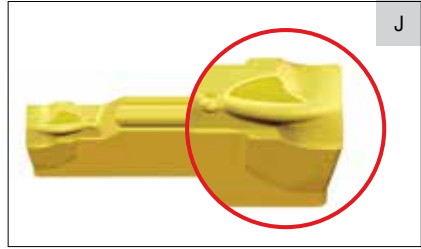

- For soft materials, parting of tubes, small diameters and thin-walled parts
- Low forces and smaller burrs
- Improved straightness
- Low-to-medium feeds

■ Recommended feed range as a function of insert width

Material; SAE4140 (HB240)

Recommendations are for neutral inserts - for R/L inserts reduce feeds by 20 - 40%

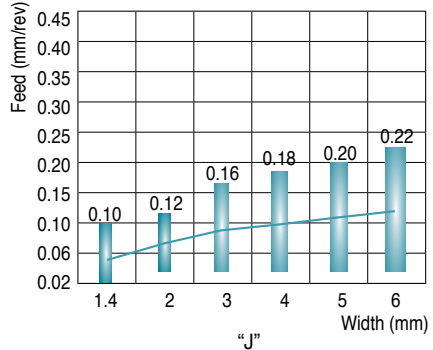
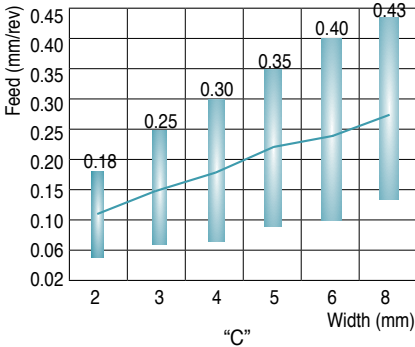

Workpiece materials					
	Alloy steel	Austenitic stainless	High - Temp alloys	Nonferrous materials	Cast iron
High ↑ Feed	C	C	C	C Brass	C
Low ↓	J	J	J Titanium	J Aluminum	

► Chip breaker style: “T” chip breaker

- The “T” chip breaker is available for turning and grooving of steel, alloy steel and stainless steel
- Inserts with “T” style chip breaker contain a central chipbreaking island for multi-direction chip control
- TDXT insert has the same chip breaker as “T” insert but it has more front & side clearance angle to use in internal and face application. This insert will cover existing grounded TDIT/TDFT insert

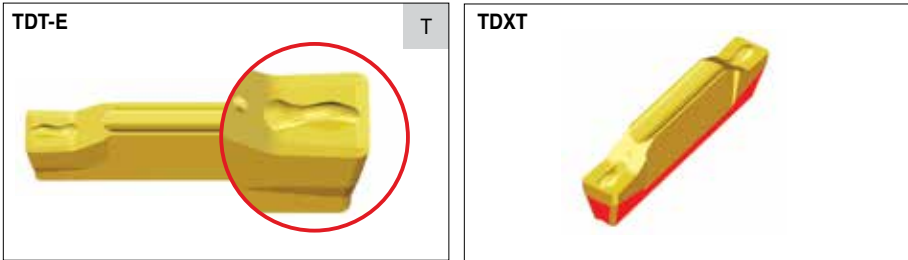

► TDT/TDXT cutting condition table

■ Grooving

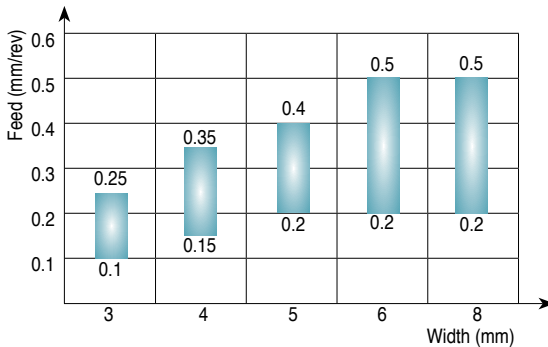

■ Turning

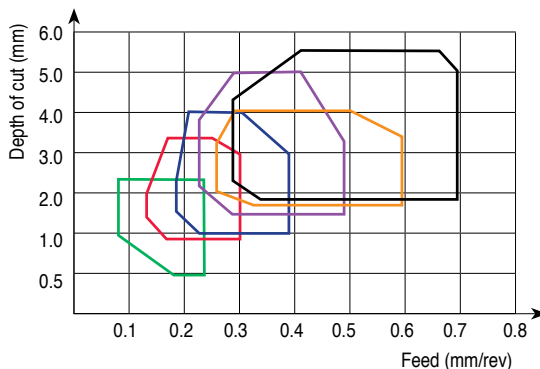

- Workpiece: SAE 1045 (C45)
- Cutting speed: $V_c=100 - 180$ m/min

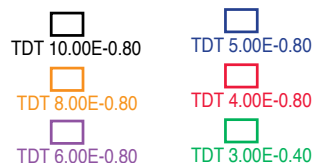

► Chip breaker style: “XU” chip breaker

- First choice on general use in grooving & turning application
- Excellent chip-control ability
- Low to medium feeds in grooving & turning
- Multipurpose for external, internal & face grooving and turning machining is possible

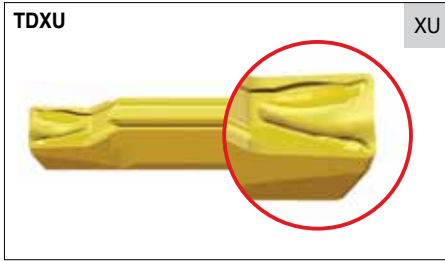

► TDXU cutting condition table

■ Grooving

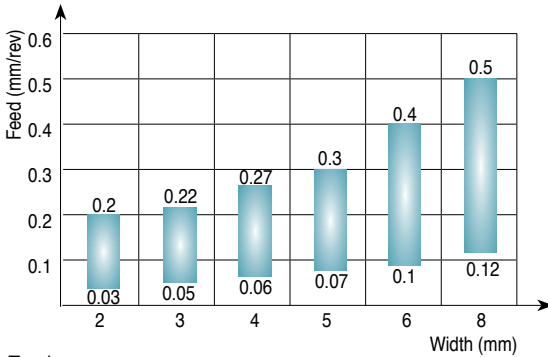

■ Turning

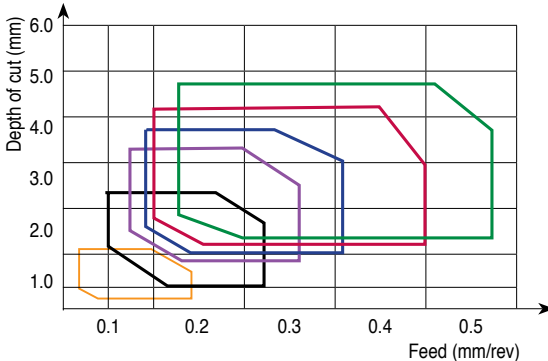

- TDXU 2E
- TDXU 5E
- TDXU 3E
- TDXU 6E
- TDXU 4E
- TDXU 8E

► TDIM, TDIP chip breaker

- Economical double-ended insert
- Multiple applications
 - TDIM: pressed insert with efficient chip breaker for boring and grooving operations
 - TDIP: ground insert for precise machining



► TDIM, TDIP cutting conditions

■ Grooving

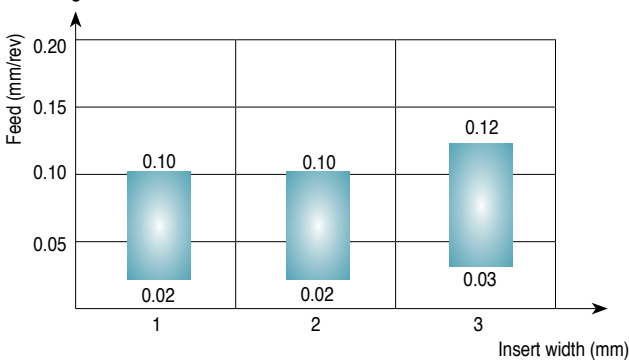

■ Turning

