

THREAD MAKING



THREAD MAKING



contents

Tool Selection Guide

T-THREAD (Thread Turning)	C4
---------------------------	----

Grades	C8
--------	----

Guide to Icons



➤ T-THREAD
Holder Page



➤ Cutting Condition Page







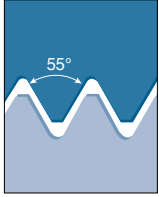
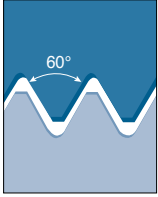
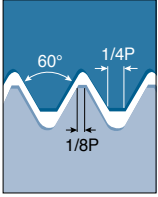
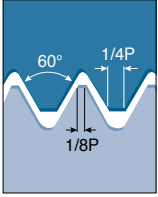

T-THREAD (Thread Turning)

Holder Designation System	C10
External Toolholders	C11
Internal Toolholders	C13
Spare Parts	C15
Insert Designation System	C18
Inserts	C19
Recommended Cutting Conditions	C54
Technical Data	C56

Tool Selection Guide

Threading inserts

Thread		T-THREAD			
		55° thread	60° thread	Metric ISO	American UN
					
Pages		C19	C20	C21 - C25	C26 - C30
Type of threading		Partial profile	Partial profile	Full profile	Full profile
Application		General use for 55° thread forms for wide range of pitches	General use for 60° thread forms for wide range of pitches	General usage for all industries	General usage for all industries
 M - type	ER	•	•	•	•
	IR	•	•	•	•
 Regular type	ER/IR	•	•	•	•
	EL/IL	•	•	•	•
 B - type	ER	•	•	•	•
	IR	•	•	•	•
 U - type	IRL	•	•	•	•
	EIRL	•	•		
	ERL			•	•
 Multi-tooth type	ER			•	•
	IR			•	•

ER: External right hand

ERL: External right / left hand

EL: External left hand

IRL: Internal Right / left hand

IR: Internal right hand

EIRL: External / internal right / left hand

IL: Internal left hand

Tool Selection Guide





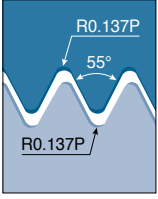
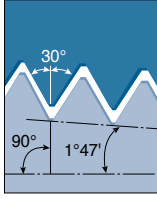
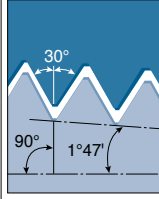
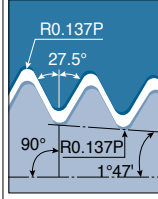
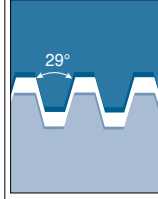
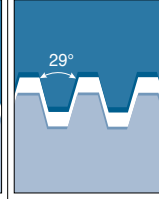

Threading inserts

T-THREAD

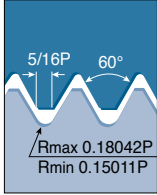
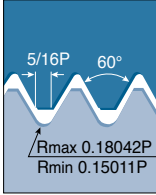
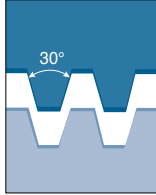
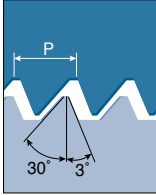
Whitworth	NPT	NPTF	BSPT	STUB ACME	ACME
					
C31 - C35	C36 - C37	C38	C39	C40	C41
Full profile	Full profile	Full profile	Full profile	Partial profile	Partial profile
General industries. Pipe fittings and couplings	Steam, gas and water pipes	Steam, gas and water pipes. Dry seal	55° form for steam, gas and water pipes	Shallow ACME profile for motion transmission	Motion transmission. Feed screws
•	•		•		
•	•		•		
•	•	•	•	•	•
•	•	•	•	•	•
•	•		•		
•	•		•		
					•
•					•
•	•				
•	•				

Tool Selection Guide

Threading inserts

		T-THREAD			
		UNJ	MJ	Trapez DIN 103	Sagengewinde DIN 513
Thread					
Pages		C42 - C43	C44	C45	C47
Type of threading		Full profile	Full profile	Partial profile	Full profile
Application		Aviation and aerospace industry	Aviation and aerospace industry	Motion transmission. Feed screws	For high force in one direction
 M - type	ER				
	IR				
 Regular type	ER/IR	●	●	●	●
	EL/IL	●		●	●
 B - type	ER				
	IR				
 U - type	ER/IR				●
	EL/IL				●
	ERL/IRL			●	
 Multi-tooth type	ER				
	IR				

ER: External right hand

EL: External left hand

IR: Internal right hand

IL: Internal left hand

ERL: External right / left hand

IRL: Internal Right / left hand

EIRL: External / internal right / left hand

Tool Selection Guide

Threading inserts

T-THREAD

American buttress	Round DIN 405	API round	API	Buttress casing	Extreme line casing
C48	C49	C50 - C51	C52	C53	C53
Full profile	Full profile	Full profile	Full profile	Full profile	Full profile
For high force in one direction	Pipe coupling in fire fighting, chemical and food industries	60° thread with large radius in the oil and gas industry	60° thread form for pipe connections in the oil and gas industry	Tube and casings in the oil and gas industry	Tube and casings in the oil and gas industry
	•				
	•				
•	•	•	•	•	•
•	•				
•					
•					

Grades

Thread making grades

Grades	ISO	Characteristics & applications
TT7010 PVD coated	<div style="display: flex; flex-wrap: wrap; gap: 5px;"> <div style="background-color: #0056b3; color: white; padding: 2px 5px;">P05</div> <div style="background-color: #0056b3; color: white; padding: 2px 5px;">P25</div> <div style="background-color: #c00000; color: white; padding: 2px 5px;">K05</div> <div style="background-color: #c00000; color: white; padding: 2px 5px;">K25</div> </div>	<ul style="list-style-type: none"> • General machining of steel and cast iron
TT8010 PVD coated	<div style="display: flex; flex-wrap: wrap; gap: 5px;"> <div style="background-color: #0056b3; color: white; padding: 2px 5px;">P30</div> <div style="background-color: #0056b3; color: white; padding: 2px 5px;">P50</div> <div style="background-color: #ffc000; color: black; padding: 2px 5px;">M30</div> <div style="background-color: #ffc000; color: black; padding: 2px 5px;">M50</div> <div style="background-color: #800000; color: white; padding: 2px 5px;">S30</div> <div style="background-color: #800000; color: white; padding: 2px 5px;">S50</div> </div>	<ul style="list-style-type: none"> • Toughest grade in threading product line • For a wide range of threading on low carbon steel & low carbon alloy steel • Medium to low speed threading of stainless steel and exotic materials
TT9030 PVD coated	<div style="display: flex; flex-wrap: wrap; gap: 5px;"> <div style="background-color: #0056b3; color: white; padding: 2px 5px;">P20</div> <div style="background-color: #0056b3; color: white; padding: 2px 5px;">P40</div> <div style="background-color: #ffc000; color: black; padding: 2px 5px;">M20</div> <div style="background-color: #ffc000; color: black; padding: 2px 5px;">M40</div> <div style="background-color: #800000; color: white; padding: 2px 5px;">S20</div> <div style="background-color: #800000; color: white; padding: 2px 5px;">S40</div> </div>	<ul style="list-style-type: none"> • General machining of steel • General machining of stainless steel • General machining of heat-resistant alloy
P30 Carbide	<div style="display: flex; flex-wrap: wrap; gap: 5px;"> <div style="background-color: #0056b3; color: white; padding: 2px 5px;">P25</div> <div style="background-color: #0056b3; color: white; padding: 2px 5px;">P35</div> </div>	<ul style="list-style-type: none"> • General machining of steel

T-THREAD

Thread Turning



Holder Designation System



1 Clamping system

S - Screw clamping

2 Application

E - External
I - Internal

3 Hand of tool

R - Right-hand
L - Left-hand

4 Shank size

External toolholders
Shank: hxb

2020: 20x20 mm

Internal toolholders
Neck diameter

0025: Neck diameter 25 mm

5 Tool length

	mm
D	- 60
F	- 80
H	- 100
K	- 125
L	- 140
M	- 150
P	- 170
R	- 200
S	- 250
T	- 300
U	- 350
V	- 400

6 Insert size

l (mm)	d
06	3.968 mm = 5/32"
08	4.762 mm = 3/16"
08U	4.762 mm = 3/16"
11	6.350 mm = 1/4"
16	9.525 mm = 3/8"
22	12.700 mm = 1/2"
22U	12.700 mm = 1/2"
27	15.875 mm = 5/8"
27U	15.875 mm = 5/8"

7 Optional specifications

U - For U-type inserts
B - Bore for coolant
C - Carbide shank
D - Drop head
G - Gang tool
AD - Short type
SP - Special

External threading toolholders

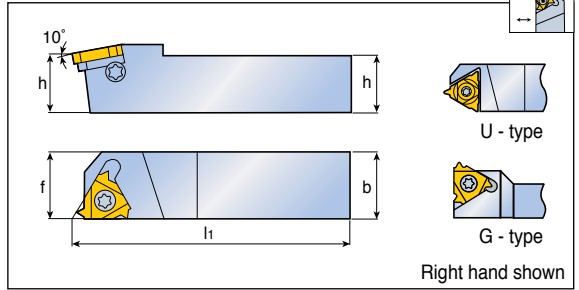

Designation	Dimension (mm)				Insert ⁽²⁾
	h	b	li	f	
SER 0808 H11 ⁽¹⁾	8	8	100	11	11 ER...
1616 K16G	16	16	125	21.7	16 ER...
4040 R27	40	40	200	40	27 ER...
SER/L 1010 H11 ⁽¹⁾	10	10	100	11	11 ER/L...
1212 F16	12	12	80	16	16 ER/L...
1616 H16	16	16	100	16	16 ER/L...
2020-16-AD	20	20	67	25	16 ER/L...
2020 K16	20	20	125	20	16 ER/L...
2525 M16	25	25	150	25	16 ER/L...
3232 P16	32	32	170	32	16 ER/L...
2525 M22	25	25	150	25	22 ER/L...
3232 P22	32	32	170	32	22 ER/L...
4040 R22	40	40	200	40	22 ER/L...
2525 M22U	25	25	150	28	22 UERL...
3232 P22U	32	32	170	32	22 UERL...
4040 R22U	40	40	200	40	22 UERL...
2525 M27	25	25	150	25	27 ER/L...
3232 P27	32	32	170	32	27 ER/L...
2525 M27U	25	25	150	32	27 UERL...
3232 P27U	32	32	170	32	27 UERL...
4040 R27U	40	40	200	40	27 UERL...

- ⁽¹⁾ Toolholders without anvil • ⁽²⁾ Right hand inserts (ER) for right hand tools (SER)
- All Toolholders are made with 1.5° helix angle
- For multi-tooth inserts use anvils AE16M, AE22M, AE27M
- Please check for spare parts C15 page

External threading dropout toolholders

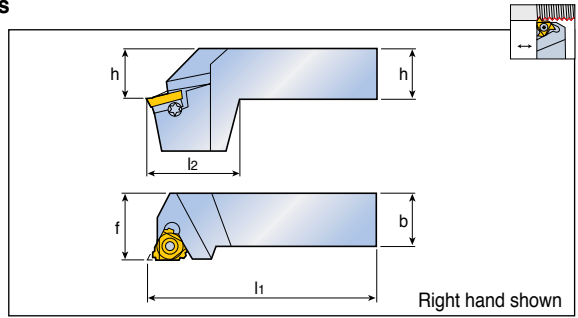

Designation	Dimension (mm)					Insert
	h	b	l ₁	f	l ₂	
SER 2020 K16D	20	20	125	25	38	16 ER...
2525 M16D	25	25	150	32	38	16 ER...
2525 M22D	25	25	150	32	38	22 ER...

- All Toolholders are made with 1.5° helix angle
- For multi-tooth inserts use anvils AE16M, AE22M, AE27M
- Please check for spare parts C15 page

Internal threading toolholders

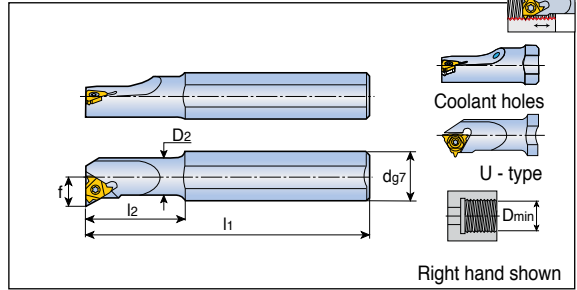

Designation	Dimension (mm)						Coolant	Insert ⁽²⁾
	d	D2	l1	l2	Dmin	f		
SIR/L 0005 H06 ⁽¹⁾	12	5.1	100	12	6.4	4.3	X	06 IR/L...
0007 K08 ⁽¹⁾	16	6.6	125	18	7.8	5.3	X	08 IR/L...
0008 K08U ⁽¹⁾	16	7.4	125	21	9.0	6.4	X	08 UIRL...
0010 H11 ⁽¹⁾	10	10	100	-	12	7.4	X	11 IR/L...
SIR 0010 H11B ⁽¹⁾	10	10	100	-	12	7.4	●	11 IR...
SIR/L 0010 K11 ⁽¹⁾	16	10	125	25	12	6.5	X	11 IR/L...
0010 K11B ⁽¹⁾	16	10	125	25	12	7.4	●	11 IR/L...
0013 L11 ⁽¹⁾	16	13	140	32	15	8.9	X	11 IR/L...
0013 M16 ⁽¹⁾	16	13	150	32	16	10.0	X	16 IR/L...
0013 M16B ⁽¹⁾	16	13	150	32	16	10.2	●	16 IR/L...
0016 P16 ⁽¹⁾	20	16	170	40	19	11.4	X	16 IR/L...
0016 P16B ⁽¹⁾	20	16	170	40	19	11.7	●	16 IR/L...
0020-16-AD	20	20	80	-	24	13.7	X	16 IR/L...
0020 P16	20	20	170	-	24	13.4	X	16 IR/L...
0020 P16B	20	20	170	-	24	13.7	●	16 IR/L...
0025-16-AD	25	25	120	-	29	16.3	X	16 IR/L...
0025 R16	25	25	200	-	29	16.3	X	16 IR/L...
0025 R16B	25	25	200	-	29	16.2	●	16 IR/L...
0032 S16	32	32	250	-	36	19.6	X	16 IR/L...
0040 T16	40	40	300	-	44	23.8	X	16 IR/L...
0050 U16	50	50	350	-	54	28.7	X	16 IR/L...
0020 P22 ⁽¹⁾	20	20	170	-	24	15.6	X	22 IR/L...
0025 R22	25	25	200	-	29	17.2	X	22 IR/L...
0025 R22B	25	25	200	-	29	18.1	●	22 IR/L...
0032 S22	32	32	250	-	38	21.5	X	22 IR/L...
0040 T22	40	40	300	-	46	25.8	X	22 IR/L...
0050 U22	50	50	350	-	56	30.6	X	22 IR/L...
0032 S22U	32	32	250	-	38	25.5	X	22 UIRL...
0040 T22U	40	40	300	-	46	29.5	X	22 UIRL...
0032 S27	32	32	250	-	40	22.4	X	27 IR/L...
0040 T27	40	40	300	-	48	26.4	X	27 IR/L...
0050 U27	50	50	350	-	58	31.4	X	27 IR/L...
0060 V27	60	60	400	-	68	36.4	X	27 IR/L...
0032 S27U	32	32	250	-	40	24.7	X	27 UIRL...
0040 T27U	40	40	300	-	48	29.4	X	27 UIRL...
0050 U27U	50	50	350	-	58	34.3	X	27 UIRL...
0060 V27U	60	60	400	-	68	39.3	X	27 UIRL...

- ⁽¹⁾ Toolholders without anvil • ⁽²⁾ Right hand inserts (IR) for right hand tools (SIR)
- For multi-tooth inserts use anvils A116M, A122M, A127M
- All Toolholders are made with 1.5° helix angle • Please check for spare parts C16 page

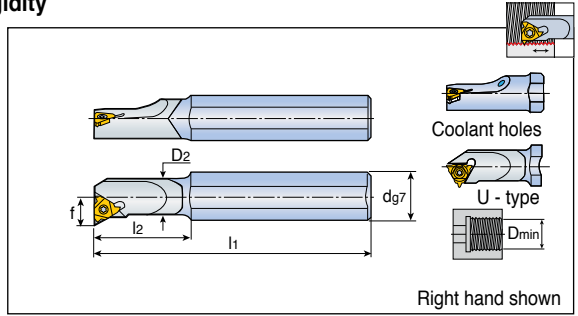

Solid carbide threading bars for high rigidity







Designation	Dimension (mm)						Coolant	Insert ⁽²⁾
	d	D2	l1	l2	Dmin	f		
SIR/L 0005 H06CB ⁽¹⁾	6	5.1	100	25	6.4	4.3	●	06 IR/L...
0007 K08CB ⁽¹⁾	8	6.6	125	30	7.8	5.3	●	08 IR/L...
0008 K08UCB ⁽¹⁾	8	7.3	125	35	9.0	6.4	●	08 UIRL...
0010 M11CB ⁽¹⁾	10	10	150	-	12	7.4	●	11 IR/L...
0012 P11CB ⁽¹⁾	12	12	170	-	15	8.4	●	11 IR/L...
0016 R16CB ⁽¹⁾	16	16	200	-	19	11.7	●	16 IR/L...
0020 S16CB	20	20	250	-	28	13.7	●	16 IR/L...
0025 S16CB	25	25	250	-	28	16.2	●	16 IR/L...

- ⁽¹⁾ Toolholders without anvil
- For multi-tooth inserts use anvils A116M, A122M, A127M
- All Toolholders are made with 1.5° helix angle
- ⁽²⁾ Right hand inserts (IR) for right hand tools (SIR)
- All carbide shank Toolholders are coolant through type
- Please check for spare parts C16 page





SER/L

Designation	Insert screw	Anvil screw	Anvil int./ext. right	Anvil int./ext. left	Torx wrench
					
SER 0808 H11	S11				T-8/5
SER/L 1010 H11	S11				T-8/5
SEL 1212 F16	S16	A16		AI16	T-10/5
SER 1212 F16	S16	A16	AE16		T-10/5
SEL 1616 H16	S16	A16		AI16	T-10/5
SER 1616 H16	S16	A16	AE16		T-10/5
SER 1616 K16G	S16	A16	AE16		T-10/5
SEL 2020-16-AD	S16	A16		AI16	T-10/5
SER 2020-16-AD	S16	A16	AE16		T-10/5
SEL 2020 K16	S16	A16		AI16	T-10/5
SER 2020 K16	S16	A16	AE16		T-10/5
SEL 2525 M16	S16	A16		AI16	T-10/5
SER 2525 M16	S16	A16	AE16		T-10/5
SEL 3232 P16	S16	A16		AI16	T-10/5
SER 3232 P16	S16	A16	AE16		T-10/5
SEL 2525 M22	S22	A22		AI22	T-20/5
SER 2525 M22	S22	A22	AE22		T-20/5
SEL 3232 P22	S22	A22		AI22	T-20/5
SER 3232 P22	S22	A22	AE22		T-20/5
SEL 4040 R22	S22	A22		AI22	T-20/5
SER 4040 R22	S22	A22	AE22		T-20/5
SEL 2525 M22U	S22	A22		AI22U	T-20/5
SER 2525 M22U	S22	A22	AE22U		T-20/5
SEL 3232 P22U	S22	A22		AI22U	T-20/5
SER 3232 P22U	S22	A22	AE22U		T-20/5
SEL 4040 R22U	S22	A22		AI22U	T-20/5
SEL 2525 M27	TS40	A27		AI27	TK40
SER 2525 M27	TS40	A27	AE27		TK40
SEL 3232 P27	TS40	A27		AI27	TK40
SER 3232 P27	TS40	A27	AE27		TK40
SER 4040 R27	TS40	A27	AE27		TK40
SEL 2525 M27U	TS40	A27		AI27U	TK40
SEL 3232 P27U	TS40	A27		AI27U	TK40
SER 3232 P27U	TS40	A27	AE27U		TK40
SEL 4040 R27U	TS40	A27		AI27U	TK40





SER-D

Designation	Insert screw	Anvil screw	Anvil int./ext. right	Anvil int./ext. left	Torx wrench
					
SER 2525 M16D	S16	A16	AE16	-	T-10/5
SER 2525 M22D	S22	A22	AE22	-	T-20/5

SIR/L

Designation	Insert screw	Anvil screw	Anvil int./ext. right	Anvil int./ext. left	Torx wrench
					
SIR/L 0005 H06	TS 20038I				T-6/5
SIR/L 0005 H06CB	TS 20038I				T-6/5
SIR 0005 H06-W	TS 20038I				T-6/5
SIR/L 0007 K08	TS 20054I				T-6/5
SIR/L 0007 K08CB	TS 20054I				T-6/5
SIR/L 0008 K08U	TS 20054I				T-6/5
SIR 0008 K08UCB	TS 20054I				T-6/5
SIR/L 0010 H11	S11				T-8/5
SIR 0010 H11B	S11				T-8/5
SIR/L 0010 K11	S11				T-8/5
SIR/L 0010 K11B	S11				T-8/5
SIR/L 0010 M11CB	S11				T-8/5
SIR/L 0012 P11CB	S11				T-8/5
SIR/L 0013 L11	S11				T-8/5
SIR/L 0013 M16	S16S				T-10/5
SIR/L 0013 M16B	S16S				T-10/5
SIR/L 0016 P16	S16S				T-10/5
SIR/L 0016 P16B	S16S				T-10/5
SIR 0016 R16CB	S16S				T-10/5
SIL 0020-16-AD	S16	A16	AE16		T-10/5
SIR 0020-16-AD	S16	A16		AI16	T-10/5
SIL 0020 P16	S16	A16	AE16		T-10/5
SIR 0020 P16	S16	A16		AI16	T-10/5
SIL 0020 P16B	S16	A16	AE16		T-10/5
SIR 0020 P16B	S16	A16		AI16	T-10/5
SIR 0020 S16CB	S16	A16		AI16	T-10/5
SIL 0025-16-AD	S16	A16	AE16		T-10/5
SIR 0025-16-AD	S16	A16		AI16	T-10/5
SIL 0025 R16	S16	A16	AE16		T-10/5
SIR 0025 R16	S16	A16		AI16	T-10/5
SIL 0025 R16B	S16	A16	AE16		T-10/5
SIR 0025 R16B	S16	A16		AI16	T-10/5
SIR 0025 S16CB	S16	A16		AI16	T-10/5
SIL 0032 S16	S16	A16	AE16		T-10/5
SIR 0032 S16	S16	A16		AI16	T-10/5
SIL 0040 T16	S16	A16	AE16		T-10/5
SIR 0040 T16	S16	A16		AI16	T-10/5
SIL 0050 U16	S16	A16	AE16		T-10/5
SIR 0050 U16	S16	A16		AI16	T-10/5

SIR/L

Designation	Insert screw	Anvil screw	Anvil int./ext. right	Anvil int./ext. left	Torx wrench
					
SIL 0020 P22	S22S				T-20/5
SIR 0020 P22	S22S				T-20/5
SIL 0025 R22	S22	A22	AE22		T-20/5
SIR 0025 R22	S22	A22		AI22	T-20/5
SIL 0025 R22B	S22	A22	AE22		T-20/5
SIR 0025 R22B	S22	A22		AI22	T-20/5
SIL 0032 S22	S22	A22	AE22		T-20/5
SIR 0032 S22	S22	A22		AI22	T-20/5
SIL 0040 T22	S22	A22	AE22		T-20/5
SIR 0040 T22	S22	A22		AI22	T-20/5
SIL 0050 U22	S22	A22	AE22		T-20/5
SIR 0050 U22	S22	A22		AI22	T-20/5
SIL 0032 S22U	S22	A22	AE22U		T-20/5
SIR 0032 S22U	S22	A22		AI22U	T-20/5
SIR 0040 T22U	S22	A22		AI22U	T-20/5
SIL 0032 S27	TS40	A27	AE27		TK40
SIR 0032 S27	TS40	A27		AI27	TK40
SIL 0040 T27	TS40	A27	AE27		TK40
SIR 0040 T27	TS40	A27		AI27	TK40
SIL 0050 U27	TS40	A27	AE27		TK40
SIR 0050 U27	TS40	A27		AI27	TK40
SIL 0060 V27	TS40	A27	AE27		TK40
SIR 0060 V27	TS40	A27		AI27	TK40
SIL 0032 S27U	TS40	A27	AE27U		TK40
SIR 0032 S27U	TS40	A27		AI27U	TK40
SIR 0040 T27U	TS40	A27		AI27U	TK40
SIL 0050 U27U	TS40	A27	AE27U		TK40
SIR 0050 U27U	TS40	A27		AI27U	TK40
SIL 0060 V27U	TS40	A27	AE27U		TK40
SIR 0060 V27U	TS40	A27		AI27U	TK40

Insert Designation System

16 E R M 1.50 ISO 2M TT9030

1 2 3 4 5 6 7 8

1 Insert size

l (mm)	d
06	3.968 mm = 5/32"
08	4.762 mm = 3/16"
11	6.350 mm = 1/4"
16	9.525 mm = 3/8"
22	12.700 mm = 1/2"
27	15.875 mm = 5/8"

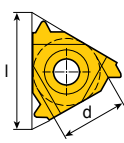

2 Application

- E - External
- I - Internal
- UE - U-type, external
- UI - U-type, Internal
- UEI - U-type, external and internal

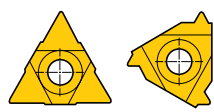

U-type Regular type

3 Hand of tool

- R - Right-hand
- L - Left-hand
- RL - Right and left-hand

4 Type

- M - With a chip breaker
- B - Peripherally ground & chip breaker
- No indication regular type

5 Pitch

Full profile
Value by number
0.35 - 9.0 mm
72 - 2 TPI

Partial profile
Range by letter

	mm	TPI
A	0.5 - 1.5	48 - 16
AG	0.5 - 3.0	48 - 8
G	1.75 - 3.0	14 - 8
N	3.5 - 5.0	7 - 5
Q	5.5 - 6.0	4.5 - 4
U	5.5 - 9.0	4.5 - 2.75

6 Thread standard

- 60 - Partial profile 60°
- 55 - Partial profile 55°
- ISO - ISO metric
- UN - American UN
- W - Whitworth
- BSPT - British BSPT
- RND - Round DIN 405
- TR - Trapeze DIN 103
- ACME - ACME
- STACME - Stub ACME
- ABUT - American buttress
- UNJ - UNJ
- MJ - MJ
- NPT - NPT
- API RD - API round
- BUT - API buttress casing
- API - API
- EL - Extreme line casing
- SAGE - Segengewinde DIN 513

7 No. of teeth (Optional)

- 2M - 2 teeth
- 3M - 3 teeth

8 Grades

Coated
TT7010
TT8010
TT9030
Uncoated
P30

Partial Profile 55°

External & internal

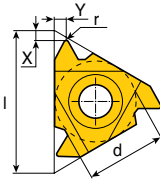



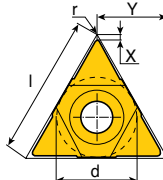

External right hand shown
(Internal left hand)

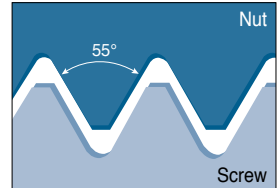

U-type



• Application: General industry

Insert	Designation	Pitch		Dimension (mm)					Coated			Uncoated
		mm	TPI	d	l	r	X	Y	TT7010	TT9030	TT8010	P30
External  Regular  B/M	11ER/L A 55	0.5-1.5	48-16	1/4"	11	0.05	0.8	0.9	●	●		●
	16ER/L A 55	0.5-1.5	48-16	3/8"	16	0.05	0.8	0.9	●	●		●
	16ER/L AG 55	0.5-3.0	48-8	3/8"	16	0.05	1.2	1.7	●	●	●	●
	16ERB AG 55	0.5-3.0	48-8	3/8"	16	0.05	1.2	1.7		●		
	16ERM AG 55	0.5-3.0	48-8	3/8"	16	0.07	1.2	1.7	●			●
	16ER/L G 55	1.75-3.0	14-8	3/8"	16	0.20	1.2	1.7	●	●		●
	16ERB G 55	1.75-3.0	14-8	3/8"	16	0.20	1.2	1.7		●		
	16ERM G 55	1.75-3.0	14-8	3/8"	16	0.23	1.2	1.7	●	●		●
	22ER/L N 55	3.5-5.0	7-5	1/2"	22	0.42	1.7	2.5	●	●		●
	27ER Q 55	5.5-6.0	4.5-4	5/8"	27	0.60	2.0	2.9	●	●		●
Internal  Regular  B/M	06IR/L A 55	0.5-1.25	48-20	5/32"	6	0.05	0.5	0.6			●	
	08IR/L A 55	0.5-1.5	48-16	3/16"	8	0.05	0.6	0.7			●	
	11IR/L A 55	0.5-1.5	48-16	1/4"	11	0.05	0.8	0.9	●	●	●	●
	16IR A 55	0.5-1.5	48-16	3/8"	16	0.05	0.8	0.9	●	●		●
	16IR/L AG 55	0.5-3.0	48-8	3/8"	16	0.05	1.2	1.7	●	●	●	●
	16IRB AG 55	0.5-3.0	48-8	3/8"	16	0.05	1.2	1.7		●		
	16IRM AG 55	0.5-3.0	48-8	3/8"	16	0.05	1.2	1.7	●			●
	16IR/L G 55	1.75-3.0	14-8	3/8"	16	0.20	1.2	1.7	●	●		●
	16IRB G 55	1.75-3.0	14-8	3/8"	16	0.20	1.2	1.7		●		
	16IRM G 55	1.75-3.0	14-8	3/8"	16	0.20	1.2	1.7	●	●		●
U 	22IR/L N 55	3.5-5.0	7-5	1/2"	22	0.42	1.7	2.5	●	●		●
	27IR/L Q 55	5.5-6.0	4.5-4	5/8"	27	0.60	2.0	2.9	●	●		●
	08UIRL U 55	1.75-2.0	14-11	3/16"	8	0.10	0.9	4.0			●	
	22UEIRL U 55	5.5-8.0	4.5-3.25	1/2"	22	0.60	0.9	11.0	●			●
	27UEIRL U 55	6.5-9.0	4-2.75	5/8"	27	0.81	1.2	13.7	●			

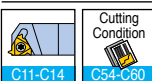

• ERB / ERM / IRB / IRM with pressed chip breaker

●: Standard items

Partial Profile 60°

T-THREAD

External & internal

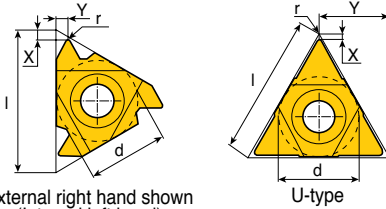



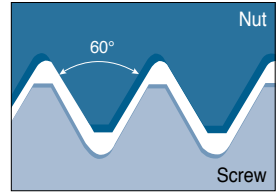

External right hand shown
(Internal left hand)

U-type



• Application: General industry

Insert	Designation	Pitch		Dimension (mm)					Coated			Uncoated	
		mm	TPI	d	l	r	X	Y	TT7010	TT9030	TT8010	P30	
 Regular	11ER/L A 60	0.5-1.5	48-16	1/4"	11	0.05	0.8	0.9	●	●		●	
	16ER/L A 60	0.5-1.5	48-16	3/8"	16	0.05	0.8	0.9	●	●	●	●	
	16ERB A 60	0.5-1.5	48-16	3/8"	16	0.05	0.8	0.9		●			
	16ERM A 60	0.5-1.5	48-16	3/8"	16	0.05	0.8	0.9	●	●		●	
	 B/M	16ER/L AG 60	0.5-3.0	48-8	3/8"	16	0.05	1.2	1.7	●	●	●	●
		16ERB AG 60	0.5-3.0	48-8	3/8"	16	0.05	1.2	1.7		●		
		16ERM AG 60	0.5-3.0	48-8	3/8"	16	0.06	1.2	1.7	●	●		●
		16ER/L G 60	1.75-3.0	14-8	3/8"	16	0.17	1.2	1.7	●	●	●	●
		16ERB G 60	1.75-3.0	14-8	3/8"	16	0.17	1.2	1.7		●		
		16ERM G 60	1.75-3.0	14-8	3/8"	16	0.17	1.2	1.7	●	●		●
	 Regular	22ER/L N 60	3.5-5.0	7-5	1/2"	22	0.32	1.7	2.5	●	●	●	●
		22ERM N 60	3.5-5.0	7-5	1/2"	22	0.32	1.7	2.5	●	●		●
27ER/L Q 60		5.5-6.0	4.5-4	5/8"	27	0.63	2.1	3.1	●		●	●	
 B/M		06IR/L A 60	0.5-1.25	48-20	5/32"	6	0.05	0.6	0.6			●	
		06IRM A 60	0.5-1.25	48-20	5/32"	6	0.05	0.5	0.6			●	
		08IR/L A 60	0.5-1.5	48-16	3/16"	8	0.05	0.6	0.7			●	
		08IRM A 60	0.5-1.5	48-16	3/16"	8	0.05	0.6	0.7		●	●	
		11IR/L A 60	0.5-1.5	48-16	1/4"	11	0.05	0.8	0.9	●	●	●	●
		11IRM A 60	0.5-1.5	48-16	1/4"	11	0.05	0.7	0.9	●	●		●
		16IR/L A 60	0.5-1.5	48-16	3/8"	16	0.05	0.8	0.9	●	●	●	●
		16IRB A 60	0.5-1.5	48-16	3/8"	16	0.05	0.8	0.9		●		
		16IRM A 60	0.5-1.5	48-16	3/8"	16	0.05	0.8	0.9	●	●		●
	16IR/L AG 60	0.5-3.0	48-8	3/8"	16	0.05	1.2	1.7	●	●	●	●	
	16IRB AG 60	0.5-3.0	48-8	3/8"	16	0.05	1.2	1.7			●		
	16IRM AG 60	0.5-3.0	48-8	3/8"	16	0.05	1.2	1.7	●	●		●	
 U	16IR/L G 60	1.75-3.0	14-8	3/8"	16	0.12	1.2	1.7	●	●	●	●	
	16IRB G 60	1.75-3.0	14-8	3/8"	16	0.12	1.2	1.7		●			
	16IRM G 60	1.75-3.0	14-8	3/8"	16	0.10	1.2	1.7	●	●		●	
	22IR/L N 60	3.5-5.0	7-5	1/2"	22	0.22	1.7	2.5	●	●	●	●	
	22IRM N 60	3.5-5.0	7-5	1/2"	22	0.19	1.7	2.5	●	●		●	
	27IR/L Q 60	5.5-6.0	4.5-4	5/8"	27	0.31	2.1	3.1	●	●		●	
	08UIRL U 60	1.75-2.0	14-11	3/16"	8	0.10	0.8	4.0			●		
22UEIRL U 60	5.5-8.0	4.5-3.25	1/2"	22	0.28	0.6	11.0	●			●		
27UEIRL U 60	6.5-9.0	4-2.75	5/8"	27	0.28	1.0	13.7	●			●		

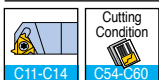

• ERB / ERM / IRB / IRM with pressed chip breaker

●: Standard items

External ISO Metric

Full profile (DIN13 12-1986 class: 6G)

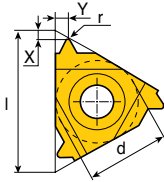

External right hand shown
(Internal left hand)

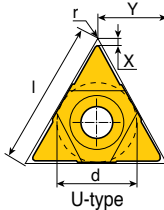

U-type

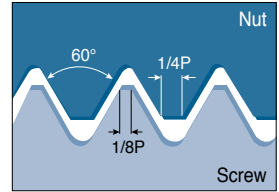

- Application: General industry

Insert	Designation	Pitch (mm)	Dimension (mm)					Coated			Uncoated
			d	l	r	X	Y	TT7010	TT9030	TT8010	P30
External	11ER/L 0.35 ISO	0.35	1/4"	11	0.04	0.8	0.4		•		•
	11ER 0.40 ISO	0.40	1/4"	11	0.04	0.7	0.4		•		
Regular	11ER 0.45 ISO	0.45	1/4"	11	0.05	0.7	0.4			•	
	11ER/L 0.50 ISO	0.50	1/4"	11	0.05	0.6	0.6	•	•	•	
	11ER 0.60 ISO	0.60	1/4"	11	0.07	0.6	0.6		•		•
	11ER 0.70 ISO	0.70	1/4"	11	0.07	0.6	0.6	•	•		•
	11ER/L 0.75 ISO	0.75	1/4"	11	0.08	0.6	0.6	•	•		•
	11ER 0.80 ISO	0.80	1/4"	11	0.09	0.6	0.6	•	•		•
	11ER/L 1.00 ISO	1.00	1/4"	11	0.12	0.7	0.7	•	•		•
	11ER 1.25 ISO	1.25	1/4"	11	0.15	0.8	0.9	•	•		•
	11ER/L 1.50 ISO	1.50	1/4"	11	0.18	0.8	1.0	•	•		•
	11ER 1.75 ISO	1.75	1/4"	11	0.21	0.8	1.1	•			
B/M	16ER/L 0.35 ISO	0.35	3/8"	16	0.04	0.8	0.4	•	•		
	16ER/L 0.40 ISO	0.40	3/8"	16	0.04	0.7	0.4		•		•
	16ER 0.45 ISO	0.45	3/8"	16	0.05	0.7	0.4	•	•		
	16ER/L 0.50 ISO	0.50	3/8"	16	0.04	0.6	0.6	•	•		•
	16ER 0.60 ISO	0.60	3/8"	16	0.07	0.6	0.6	•	•		•
	16ER/L 0.70 ISO	0.70	3/8"	16	0.07	0.6	0.6	•	•		•
	16ER/L 0.75 ISO	0.75	3/8"	16	0.08	0.6	0.6	•	•		•
	16ERM 0.75 ISO	0.75	3/8"	16	0.08	0.6	0.6		•		
	16ER/L 0.80 ISO	0.80	3/8"	16	0.09	0.6	0.6	•	•		•
	16ERB 0.80 ISO	0.80	3/8"	16	0.09	0.6	0.6		•		
	16ER/L 1.00 ISO	1.00	3/8"	16	0.12	0.7	0.7	•	•	•	•
	16ERB 1.00 ISO	1.00	3/8"	16	0.12	0.7	0.7		•		
	16ERM 1.00 ISO	1.00	3/8"	16	0.11	0.7	0.7	•	•		•
	16ER/L 1.25 ISO	1.25	3/8"	16	0.15	0.8	0.9	•	•		•
	16ERB 1.25 ISO	1.25	3/8"	16	0.15	0.8	0.9		•		
	16ERM 1.25 ISO	1.25	3/8"	16	0.14	0.8	0.9	•	•		•
	16ER/L 1.50 ISO	1.50	3/8"	16	0.18	0.8	1.0	•	•	•	•
	16ERB 1.50 ISO	1.50	3/8"	16	0.18	0.8	1.0		•		
	16ERM 1.50 ISO	1.50	3/8"	16	0.19	0.8	1.0	•	•		•
	16ER/L 1.75 ISO	1.75	3/8"	16	0.21	0.9	1.2	•	•	•	•
16ERB 1.75 ISO	1.75	3/8"	16	0.21	0.9	1.2		•			
16ERM 1.75 ISO	1.75	3/8"	16	0.20	0.9	1.2	•	•		•	

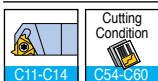

- ERB / ERM with pressed chip breaker



- Standard items

External ISO Metric

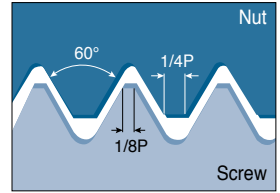
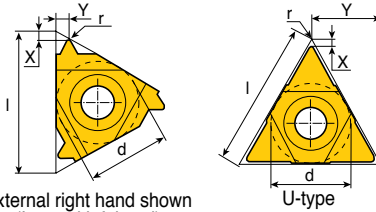
Full profile (DIN13 12-1986 class: 6G)



• Application: General industry

Insert	Designation	Pitch (mm)	Dimension (mm)					Coated			Uncoated
			d	l	r	X	Y	TT7010	TT9030	TT8010	P30
External  Regular  B/M	16ER/L 2.00 ISO	2.00	3/8"	16	0.25	1.0	1.3	●	●	●	●
	16ERB 2.00 ISO	2.00	3/8"	16	0.25	1.0	1.3		●		
	16ERM 2.00 ISO	2.00	3/8"	16	0.24	1.0	1.3	●	●		●
	16ER/L 2.50 ISO	2.50	3/8"	16	0.31	1.1	1.5	●	●		●
	16ERB 2.50 ISO	2.50	3/8"	16	0.31	1.1	1.5		●		
	16ERM 2.50 ISO	2.50	3/8"	16	0.30	1.1	1.5	●	●		●
	16ER/L 3.00 ISO	3.00	3/8"	16	0.38	1.2	1.6	●	●	●	●
	16ERB 3.00 ISO	3.00	3/8"	16	0.38	1.2	1.6		●		
	16ERM 3.00 ISO	3.00	3/8"	16	0.38	1.2	1.6	●	●		●
	22ER/L 3.50 ISO	3.50	1/2"	22	0.44	1.6	2.3	●	●	●	●
	22ERM 3.50 ISO	3.50	1/2"	22	0.44	1.6	2.3		●		
	22ER/L 4.00 ISO	4.00	1/2"	22	0.52	1.6	2.3	●	●		●
	22ERM 4.00 ISO	4.00	1/2"	22	0.52	1.6	2.3		●		
	22ER/L 4.50 ISO	4.50	1/2"	22	0.58	1.7	2.4	●	●		●
	22ER/L 5.00 ISO	5.00	1/2"	22	0.64	1.7	2.5	●	●		●
22ER/L 6.00 ISO	6.00	1/2"	22	0.78	2.0	2.7	●	●		●	
27ER/L 5.50 ISO	5.50	5/8"	27	0.70	1.9	2.7	●	●			
27ER/L 6.00 ISO	6.00	5/8"	27	0.78	2.0	2.9	●	●	●	●	
 U	22UERL 5.50 ISO	5.50	1/2"	22	0.70	2.3	11.0	●		●	
	22UERL 6.00 ISO	6.00	1/2"	22	0.78	2.6	11.0	●	●	●	
	27UERL 8.00 ISO	8.00	5/8"	27	1.08	2.4	13.7	●	●		

• ERB / ERM with pressed chip breaker

●: Standard items

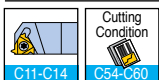

Internal ISO Metric

Full profile (DIN13 12-1986 class: 6H)

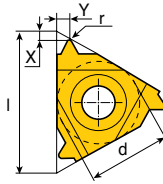

External right hand shown
(Internal left hand)

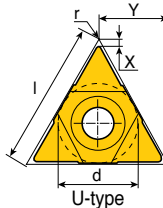

U-type

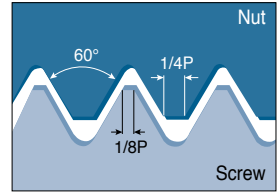

• Application: General industry

Insert	Designation	Pitch (mm)	Dimension (mm)					Coated			Uncoated
			d	l	r	X	Y	TT7010	TT9030	TT8010	P30
Internal	06IR/L 0.50 ISO	0.50	5/32"	6	0.03	0.9	0.5			•	
	06IR/L 0.75 ISO	0.75	5/32"	6	0.04	0.8	0.5			•	
Regular	06IR/L 1.00 ISO	1.00	5/32"	6	0.05	0.7	0.6			•	
	06IR/L 1.25 ISO	1.25	5/32"	6	0.07	0.6	0.6			•	
B/M	08IR/L 0.50 ISO	0.50	3/16"	8	0.05	0.6	0.5			•	
	08IR 0.75 ISO	0.75	3/16"	8	0.04	0.6	0.5			•	
	08IR/L 1.00 ISO	1.00	3/16"	8	0.05	0.6	0.6		•	•	
	08IR/L 1.25 ISO	1.25	3/16"	8	0.07	0.6	0.7			•	
	08IR/L 1.50 ISO	1.50	3/16"	8	0.08	0.6	0.7			•	
	08IR/L 1.75 ISO	1.75	3/16"	8	0.10	0.6	0.8			•	
	11IR/L 0.35 ISO	0.35	1/4"	11	0.02	0.8	0.3		•		
	11IR 0.40 ISO	0.40	1/4"	11	0.02	0.8	0.4		•		
	11IR/L 0.50 ISO	0.50	1/4"	11	0.03	0.6	0.6	•	•		•
	11IR 0.70 ISO	0.70	1/4"	11	0.04	0.6	0.6		•		
	11IR/L 0.75 ISO	0.75	1/4"	11	0.05	0.6	0.6	•	•		•
	11IR 0.80 ISO	0.80	1/4"	11	0.04	0.6	0.6	•	•		•
	11IR/L 1.00 ISO	1.00	1/4"	11	0.05	0.6	0.7	•	•	•	•
	11IRM 1.00 ISO	1.00	1/4"	11	0.05	0.6	0.7		•		
	11IR/L 1.25 ISO	1.25	1/4"	11	0.07	0.8	0.8	•	•		•
	11IR/L 1.50 ISO	1.50	1/4"	11	0.08	0.8	1.0	•	•	•	•
11IRM 1.50 ISO	1.50	1/4"	11	0.08	0.8	1.0	•	•			
11IR/L 1.75 ISO	1.75	1/4"	11	0.10	0.8	1.1	•	•		•	
11IR/L 2.00 ISO	2.00	1/4"	11	0.12	0.8	0.9	•	•	•		
16IR 0.35 ISO	0.35	3/8"	16	0.02	0.8	0.3		•			
16IR/L 0.40 ISO	0.40	3/8"	16	0.02	0.8	0.4		•			
16IL 0.45 ISO	0.45	3/8"	16	0.02	0.8	0.4		•			
16IR/L 0.50 ISO	0.50	3/8"	16	0.03	0.6	0.6	•	•		•	
16IR/L 0.60 ISO	0.60	3/8"	16	0.03	0.6	0.6		•		•	
16IR/L 0.70 ISO	0.70	3/8"	16	0.04	0.6	0.6	•	•		•	
16IR/L 0.75 ISO	0.75	3/8"	16	0.04	0.6	0.6	•	•	•	•	
16IR/L 0.80 ISO	0.80	3/8"	16	0.04	0.6	0.6	•	•		•	
16IR/L 1.00 ISO	1.00	3/8"	16	0.05	0.6	0.7	•	•		•	
16IRB 1.00 ISO	1.00	3/8"	16	0.05	0.6	0.7		•			
16IRM 1.00 ISO	1.00	3/8"	16	0.05	0.6	0.7	•	•		•	

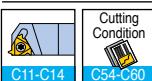

• IRB / IRM with pressed chip breaker

• Standard items

Internal ISO Metric

Full profile (DIN13 12-1986 class: 6H)

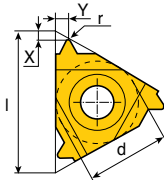



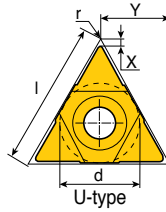

External right hand shown
(Internal left hand)

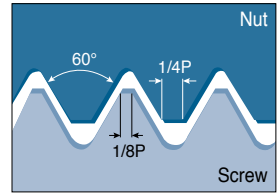

U-type



• Application: General industry

Insert	Designation	Pitch (mm)	Dimension (mm)					Coated			Uncoated
			d	l	r	X	Y	TT7010	TT9030	TT8010	P30
 Internal  Regular  B/M	16IR/L 1.25 ISO	1.25	3/8"	16	0.07	0.8	0.9	●	●	●	●
	16IRB 1.25 ISO	1.25	3/8"	16	0.07	0.8	0.9		●		
	16IRM 1.25 ISO	1.25	3/8"	16	0.06	0.8	0.9	●	●		●
	16IR/L 1.50 ISO	1.50	3/8"	16	0.08	0.8	1.0	●	●	●	●
	16IRB 1.50 ISO	1.50	3/8"	16	0.08	0.8	1.0		●		
	16IRM 1.50 ISO	1.50	3/8"	16	0.08	0.8	1.0	●	●		●
	16IR/L 1.75 ISO	1.75	3/8"	16	0.10	0.9	1.2	●	●		●
	16IRB 1.75 ISO	1.75	3/8"	16	0.10	0.9	1.2		●		
	16IRM 1.75 ISO	1.75	3/8"	16	0.10	0.9	1.2	●	●		●
	16IR/L 2.00 ISO	2.00	3/8"	16	0.12	1.0	1.3	●	●	●	●
	16IRB 2.00 ISO	2.00	3/8"	16	0.12	1.0	1.3		●		
	16IRM 2.00 ISO	2.00	3/8"	16	0.11	1.0	1.3	●	●		●
	16IR/L 2.50 ISO	2.50	3/8"	16	0.15	1.1	1.5	●	●	●	●
	16IRB 2.50 ISO	2.50	3/8"	16	0.15	1.1	1.5		●		
	16IRM 2.50 ISO	2.50	3/8"	16	0.14	1.1	1.5	●	●		●
	16IR/L 3.00 ISO	3.00	3/8"	16	0.18	1.1	1.5	●	●	●	●
	16IRB 3.00 ISO	3.00	3/8"	16	0.18	1.1	1.5		●		
	16IRM 3.00 ISO	3.00	3/8"	16	0.17	1.1	1.5	●	●		●
	22IL 3.00 ISO	3.00	1/2"	22	0.17	1.1	1.5			●	
	22IR/L 3.50 ISO	3.50	1/2"	22	0.22	1.6	2.3	●	●		●
22IR/L 4.00 ISO	4.00	1/2"	22	0.25	1.6	2.3	●	●		●	
22IR/L 4.50 ISO	4.50	1/2"	22	0.29	1.6	2.4	●	●		●	
22IR/L 5.00 ISO	5.00	1/2"	22	0.32	1.6	2.3	●	●		●	
27IR/L 5.50 ISO	5.50	5/8"	27	0.35	1.6	2.3	●	●	●		
27IR/L 6.00 ISO	6.00	5/8"	27	0.39	1.8	2.5	●	●		●	
 U	08UIRL 2.00 ISO	2.00	3/16"	8	0.12	0.9	4.0			●	
	22UIRL 5.50 ISO	5.50	1/2"	22	0.35	2.4	11.0	●			●
	22UIRL 6.00 ISO	6.00	1/2"	22	0.39	2.1	11.0	●			●
	27UIRL 8.00 ISO	8.00	5/8"	27	0.53	2.4	13.7		●		

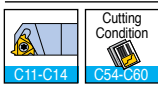

• IRB / IRM with pressed chip breaker

●: Standard items

External & Internal ISO Metric

T-THREAD

Full profile, multi-tooth

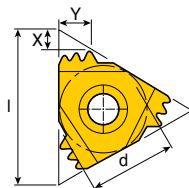

External right hand shown
(Internal left hand)

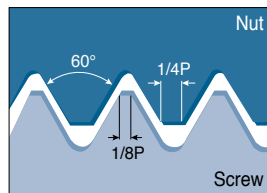

- Application: General industry

Insert	Designation	Pitch (mm)	Dimension (mm)				No. of Teeth	Coated			Uncoated
			d	l	X	Y		TT7010	TT9030	TT8010	P30
Internal / External 	16ER 0.75 ISO 3M	0.75	3/8"	16	1.3	1.9	3		●		
	16ER/IR 1.00 ISO 3M	1.0	3/8"	16	1.7	2.5	3		●		
	16ER/IR 1.50 ISO 2M	1.5	3/8"	16	1.5	2.3	2	●	●		
	16ER/IR 2.00 ISO 2M	2.00	3/8"	16	2.0	3.0	2		●		
	22ER/IR 1.50 ISO 3M	1.5	1/2"	22	2.3	3.7	3	●	●		
	22ER/IR 2.00 ISO 2M	2.0	1/2"	22	2.0	3.0	2		●		
	22ER/IR 2.00 ISO 3M	2.0	1/2"	22	3.1	5.0	3	●	●		
	27ER/IR 3.00 ISO 2M	3.0	5/8"	27	2.9	4.6	2		●		

●: Standard items

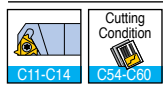

External American UN

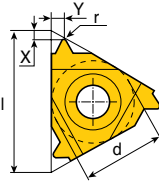

Full profile, UN, UNC, UNF, UNEF

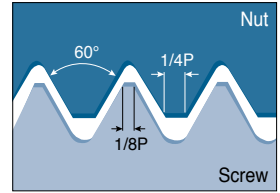

External right hand shown
(Internal left hand)



• Application: General industry

Insert	Designation	TPI	Dimension (mm)					Coated			Uncoated
			d	l	r	X	Y	TT7010	TT9030	TT8010	P30
 External  Regular  B/M	11ER 44 UN	44	1/4"	11	0.05	0.6	0.6		●		
	11ER 36 UN	36	1/4"	11	0.07	0.6	0.6		●		
	11ER 32 UN	32	1/4"	11	0.09	0.6	0.6		●		
	11ER/L 28 UN	28	1/4"	11	0.10	0.6	0.7		●		●
	11ER/L 24 UN	24	1/4"	11	0.12	0.7	0.8		●		
	11ER/L 20 UN	20	1/4"	11	0.15	0.8	0.9	●	●		
	11ER 18 UN	18	1/4"	11	0.17	0.8	1.0		●		
	11ER 16 UN	16	1/4"	11	0.18	0.9	1.1	●	●		●
	16ER 72 UN	72	3/8"	16	-	0.8	0.4		●		
	16ER 56 UN	56	3/8"	16	0.04	0.7	0.4		●		
	16ER 48 UN	48	3/8"	16	0.05	0.6	0.6		●	●	
	16ER/L 40 UN	40	3/8"	16	0.06	0.6	0.6		●	●	
	16ER/L 36 UN	36	3/8"	16	0.07	0.6	0.6		●		●
	16ER/L 32 UN	32	3/8"	16	0.09	0.6	0.6	●	●		●
	16ER/L 28 UN	28	3/8"	16	0.10	0.6	0.7	●	●		●
	16ER/L 24 UN	24	3/8"	16	0.12	0.7	0.8	●	●	●	
	16ERB 24 UN	24	3/8"	16	0.12	0.7	0.8		●		
	16ERM 24 UN	24	3/8"	16	0.11	0.7	0.8	●	●		●
	16ER/L 20 UN	20	3/8"	16	0.15	0.8	0.9	●	●		●
	16ERB 20 UN	20	3/8"	16	0.15	0.8	0.9		●		
	16ERM 20 UN	20	3/8"	16	0.14	0.8	0.9	●	●		●
	16ER/L 18 UN	18	3/8"	16	0.17	0.8	1.0	●	●		●
	16ERB 18 UN	18	3/8"	16	0.17	0.8	1.0		●		
	16ERM 18 UN	18	3/8"	16	0.15	0.8	1.0	●	●	●	●
	16ER/L 16 UN	16	3/8"	16	0.18	0.9	1.1	●	●	●	●
	16ERB 16 UN	16	3/8"	16	0.18	0.9	1.1		●		
	16ERM 16 UN	16	3/8"	16	0.19	0.9	1.1	●	●		●
	16ER/L 14 UN	14	3/8"	16	0.22	1.0	1.2	●	●		●
	16ERB 14 UN	14	3/8"	16	0.22	1.0	1.2		●		
	16ERM 14 UN	14	3/8"	16	0.22	1.0	1.2	●	●		●
	16ER/L 13 UN	13	3/8"	16	0.24	1.0	1.3	●	●		●
	16ERB 13 UN	13	3/8"	16	0.24	1.0	1.3		●		
	16ERM 13 UN	13	3/8"	16	0.24	1.0	1.3		●		

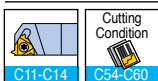

• ERB / ERM with pressed chip breaker
• Tolerance: Class 2A

●: Standard items

External American UN

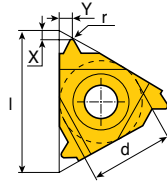

Full profile, UN, UNC, UNF, UNEF

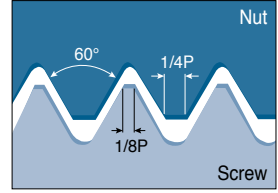

External right hand shown
(Internal left hand)



• Application: General industry

Insert	Designation	TPI	Dimension (mm)					Coated			Uncoated
			d	l	r	X	Y	TT7010	TT9030	TT8010	P30
External 	16ER/L 12 UN	12	3/8"	16	0.26	1.1	1.4	•	•		•
	16ERB 12 UN	12	3/8"	16	0.26	1.1	1.4		•		
	16ERM 12 UN	12	3/8"	16	0.25	1.1	1.4	•	•		•
Regular 	16ER 11.5 UN	11.5	3/8"	16	0.27	1.1	1.5	•	•		•
	16ER/L 11 UN	11	3/8"	16	0.28	1.1	1.5	•	•		•
	16ERB 11 UN	11	3/8"	16	0.28	1.1	1.5		•		
B/M 	16ER/L 10 UN	10	3/8"	16	0.32	1.1	1.5	•	•		•
	16ERB 10 UN	10	3/8"	16	0.32	1.1	1.5		•		
	16ER/L 9 UN	9	3/8"	16	0.36	1.2	1.7		•		•
	16ERB 9 UN	9	3/8"	16	0.36	1.2	1.7		•		
	16ER/L 8 UN	8	3/8"	16	0.41	1.2	1.6	•	•		•
	16ERB 8 UN	8	3/8"	16	0.41	1.2	1.6		•		
	16ERM 8 UN	8	3/8"	16	0.41	1.2	1.6	•	•		•
	22ER 7 UN	7	1/2"	22	0.47	1.6	2.3	•			•
	22ER/L 6 UN	6	1/2"	22	0.67	1.6	2.3	•	•		•
	22ER 5 UN	5	1/2"	22	0.67	1.7	2.5	•	•		•
27ER 4.5 UN	4.5	5/8"	27	0.75	1.9	2.7		•		•	
27ER/L 4 UN	4	5/8"	27	0.85	2.1	3.0	•			•	

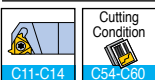

- ERB / ERM with pressed chip breaker
- Tolerance: Class 2A

• Standard items

Internal American UN

Full profile, UN, UNC, UNF, UNEF

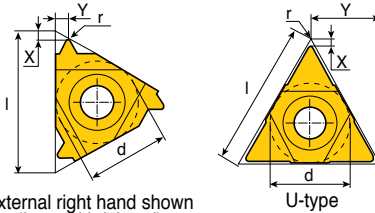

External right hand shown
(Internal left hand)

U-type

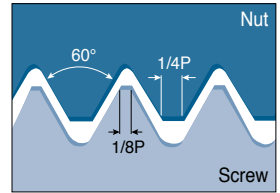

• Application: General industry

Insert	Designation	TPI	Dimension (mm)					Coated			Uncoated
			d	l	r	X	Y	TT7010	TT9030	TT8010	P30
Internal	06IR 32 UN	32	5/32"	6	0.04	0.8	0.5			●	
	06IL 28 UN	28	5/32"	6	0.04	0.8	0.6			●	
Regular	06IR/L 24 UN	24	5/32"	6	0.05	0.7	0.6			●	
	06IR/L 20 UN	20	5/32"	6	0.06	0.6	0.6			●	
B/M	06IR/L 18 UN	18	5/32"	6	0.07	0.6	0.7			●	
	08IR 32 UN	32	3/16"	8	0.04	0.6	0.5			●	
	08IR/L 28 UN	28	3/16"	8	0.04	0.6	0.6			●	
	08IR/L 24 UN	24	3/16"	8	0.05	0.6	0.6			●	
	08IR/L 20 UN	20	3/16"	8	0.06	0.6	0.7			●	
	08IR 18 UN	18	3/16"	8	0.07	0.6	0.7			●	
	08IR/L 16 UN	16	3/16"	8	0.09	0.6	0.7			●	
	08IR 14 UN	14	3/16"	8	0.10	0.6	0.8		●	●	
	11IR 64 UN	64	1/4"	11	0.02	0.8	0.4		●		
	11IR 36 UN	36	1/4"	11	0.04	0.6	0.6		●		
11IR/L 32 UN	32	1/4"	11	0.04	0.6	0.6		●		●	
11IR/L 28 UN	28	1/4"	11	0.04	0.6	0.7		●			
11IR/L 24 UN	24	1/4"	11	0.05	0.7	0.8	●	●		●	
11IR/L 20 UN	20	1/4"	11	0.06	0.8	0.9		●		●	
11IR/L 18 UN	18	1/4"	11	0.07	0.8	1.0	●	●		●	
11IR/L 16 UN	16	1/4"	11	0.09	0.9	1.1	●	●	●	●	
11IR/L 14 UN	14	1/4"	11	0.10	0.9	1.1	●	●		●	
11IR 12 UN	12	1/4"	11	0.12	0.9	1.1	●				
11IR 11 UN	11	1/4"	11	0.14	0.8	1.1	●				
16IR 44 UN	44	3/8"	16	0.03	0.6	0.6		●			
16IR 32 UN	32	3/8"	16	0.04	0.6	0.6	●	●		●	
16IR 27 UN	27	3/8"	16	0.04	0.7	0.8				●	
16IR/L 28 UN	28	3/8"	16	0.04	0.6	0.7		●		●	
16IR 24 UN	24	3/8"	16	0.05	0.7	0.8	●	●		●	
16IRB 24 UN	24	3/8"	16	0.05	0.7	0.8		●			
16IR/L 20 UN	20	3/8"	16	0.06	0.8	0.9	●	●		●	
16IRB 20 UN	20	3/8"	16	0.06	0.8	0.9		●			
16IRM 20 UN	20	3/8"	16	0.06	0.8	0.9	●	●		●	
16IR/L 18 UN	18	3/8"	16	0.07	0.8	1.0	●	●		●	
16IRB 18 UN	18	3/8"	16	0.07	0.8	1.0		●			
16IRM 18 UN	18	3/8"	16	0.08	0.8	1.0	●	●		●	

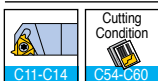

- IRB / IRM with pressed chip breaker
- Tolerance: Class 2B, ANSI B1, 3M-1986



●: Standard items

Internal American UN

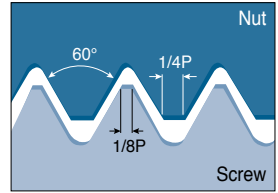
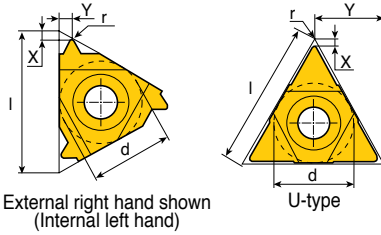
Full profile, UN, UNC, UNF, UNEF



• Application: General industry

Insert	Designation	TPI	Dimension (mm)					Coated			Uncoated
			d	l	r	X	Y	TT7010	TT9030	TT8010	P30
Internal  Regular  B/M	16IR/L 16 UN	16	3/8"	16	0.09	0.9	1.1	•	•		•
	16IRB 16 UN	16	3/8"	16	0.09	0.9	1.1		•		
	16IRM 16 UN	16	3/8"	16	0.09	0.9	1.1	•	•		•
	16IR/L 14 UN	14	3/8"	16	0.10	0.9	1.2	•	•		•
	16IRB 14 UN	14	3/8"	16	0.10	0.9	1.2		•		
	16IRM 14 UN	14	3/8"	16	0.11	0.9	1.2	•	•		•
	16IR/L 13 UN	13	3/8"	16	0.11	1.0	1.3		•		•
	16IR/L 12 UN	12	3/8"	16	0.12	1.1	1.4	•	•	•	•
	16IRM 12 UN	12	3/8"	16	0.12	1.1	1.4	•	•		•
	16IR 11.5 UN	11.5	3/8"	16	0.13	1.1	1.5		•		•
	16IR 11 UN	11	3/8"	16	0.14	1.1	1.5	•	•		•
	16IR/L 10 UN	10	3/8"	16	0.15	1.1	1.5	•	•		•
	16IRB 10 UN	10	3/8"	16	0.15	1.1	1.5		•		
	16IR 9 UN	9	3/8"	16	0.17	1.2	1.7		•		
	16IR/L 8 UN	8	3/8"	16	0.19	1.1	1.5	•	•		•
	16IRB 8 UN	8	3/8"	16	0.19	1.1	1.5		•		
	16IRM 8 UN	8	3/8"	16	0.20	1.1	1.5	•	•		•
	22IR/L 7 UN	7	1/2"	22	0.22	1.6	2.3	•	•	•	
	22IR/L 6 UN	6	1/2"	22	0.26	1.6	2.3	•	•		•
	22IR 5 UN	5	1/2"	22	0.32	1.6	2.3	•			•
27IR 4.5 UN	4.5	5/8"	27	0.36	1.7	2.4	•				
27IR/L 4 UN	4	5/8"	27	0.41	1.8	2.7	•	•		•	
Internal  U	08UIRL 13 UN	13	3/16"	8	0.10	1.0	4.0		•		
	08UIRL 12 UN	12	3/16"	8	0.10	0.9	4.0	•			
	08UIRL 11 UN	11	3/16"	8	0.10	0.9	4.0	•			
	22UIRL 4.5 UN	4.5	1/2"	22	0.36	2.4	11.0	•			
	22UIRL 4 UN	4	1/2"	22	0.41	2.4	11.0		•		

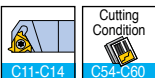

- IRB / IRM with pressed chip breaker
- Tolerance: Class 2B, ANSI B1, 3M-1986

• Standard items

External & Internal American UN

Full profile, multi-tooth, UN, UNC, UNF, UNEF

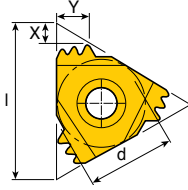

External right hand shown
(Internal left hand)

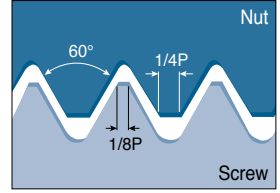

- Application: General industry

Insert	Designation	TPI	Dimension (mm)				No. of Teeth	Coated			Uncoated
			d	l	X	Y		TT7010	TT9030	TT8010	P30
Internal / External 	16ER/IR 16 UN 2M	16	3/8"	16	1.5	2.3	2	•			
	16ER 12 UN 2M	12	3/8"	16	2.2	3.4	2	•			
	22ER/IR 16 UN 3M	16	1/2"	22	2.5	4.0	3	•			
	22ER/IR 12 UN 3M	12	1/2"	22	2.2	3.4	2	•			
	22ER/IR 12 UN 3M	12	1/2"	22	3.3	5.3	3	•		•	
	27ER/IR 8 UN 2M	8	5/8"	27	3.1	4.9	2	•			

•: Standard items

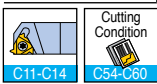

External Whitworth

Full profile, BSW, BSF, BSP (B.S. 84-1956 DIN 259)

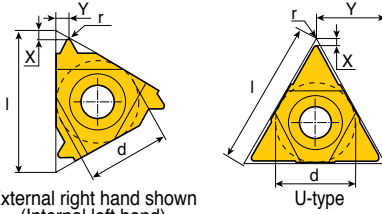



External right hand shown
(Internal left hand)

U-type

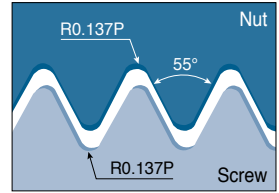
- Application: General industry, fittings and pipe couplings



Insert	Designation	TPI	Dimension (mm)					Coated			Uncoated
			d	l	r	X	Y	TT7010	TT9030	TT8010	P30
External 	11ER 36 W	36	1/4"	11	0.07	0.6	0.6		•		
	11ER 20 W	20	1/4"	11	0.14	0.8	0.9				•
	11ER/L 19 W	19	1/4"	11	0.15	0.8	1.0		•		
Regular 	11ER 18 W	18	1/4"	11	0.16	0.8	1.0	•			
	11ER 16 W	16	1/4"	11	0.18	0.9	1.1				•
B/M 	11ER 14 W	14	1/4"	11	0.21	0.9	1.1	•			•
	16ER/L 32 W	32	3/8"	16	0.09	0.6	0.6		•		•
	16ER/L 28 W	28	3/8"	16	0.09	0.6	0.7	•	•		•
	16ER 26 W	26	3/8"	16	0.10	0.7	0.7	•	•		•
	16ER/L 24 W	24	3/8"	16	0.11	0.7	0.8	•	•		•
	16ER/L 22 W	22	3/8"	16	0.13	0.8	0.9	•	•		•
	16ER 20 W	20	3/8"	16	0.14	0.8	0.9	•	•	•	•
	16ER/L 19 W	19	3/8"	16	0.15	0.8	1.0	•	•	•	•
	16ERB 19 W	19	3/8"	16	0.15	0.8	1.0		•		
	16ERM 19 W	19	3/8"	16	0.16	0.8	1.0	•	•		•
	16ER/L 18 W	18	3/8"	16	0.16	0.8	1.0	•	•		•
	16ER/L 16 W	16	3/8"	16	0.18	0.9	1.1	•	•		•
	16ERB 16 W	16	3/8"	16	0.18	0.9	1.1		•		
	16ERM 16 W	16	3/8"	16	0.20	0.9	1.1	•	•		•
	16ER/L 14 W	14	3/8"	16	0.21	1.0	1.2	•	•	•	•
	16ERB 14 W	14	3/8"	16	0.21	1.0	1.2		•		
	16ERM 14 W	14	3/8"	16	0.24	1.0	1.2	•	•		•
	16ER/L 12 W	12	3/8"	16	0.25	1.1	1.4	•	•		•
	16ER/L 11 W	11	3/8"	16	0.27	1.1	1.5	•	•	•	•
	16ERB 11 W	11	3/8"	16	0.27	1.1	1.5		•		
	16ERM 11 W	11	3/8"	16	0.27	1.1	1.5	•	•		•
	16ER/L 10 W	10	3/8"	16	0.31	1.1	1.5	•	•		•
	16ERB 10 W	10	3/8"	16	0.31	1.1	1.5		•		
	16ER 9 W	9	3/8"	16	0.34	1.2	1.7	•			•
	16ER/L 8 W	8	3/8"	16	0.39	1.2	1.5	•	•		•
	22ER 7 W	7	1/2"	22	0.45	1.6	2.3		•		•
	22ER 6 W	6	1/2"	22	0.52	1.6	2.3	•	•		•
	22ER 5 W	5	1/2"	22	0.65	1.7	2.4	•			•
27ER 4.5 W	4.5	5/8"	27	0.73	1.8	2.6				•	
27ER 4 W	4	5/8"	27	0.82	2.0	2.9		•		•	

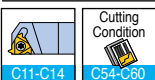

- ERB / ERM with pressed chip breaker
- Tolerance: Medium class

- Standard items

Internal Whitworth

Full profile, BSW, BSF, BSP (B.S. 84-1956 DIN 259)

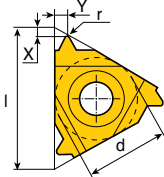



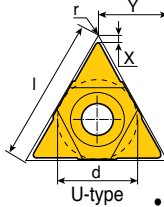

External right hand shown
(Internal left hand)

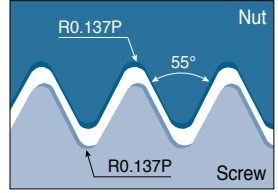

U-type

• Application: General industry, fittings and pipe couplings



Insert	Designation	TPI	Dimension (mm)					Coated			Uncoated	
			d	l	r	X	Y	TT7010	TT9030	TT8010	P30	
Internal 	06IR 26 W	26	5/32"	6	0.10	0.7	0.6				●	
	06IR 20 W	20	5/32"	6	0.14	0.6	0.7				●	
	08IR 28 W	28	3/16"	8	0.09	0.6	0.6				●	
Regular 	08IR 24 W	24	3/16"	8	0.11	0.6	0.6				●	
	08IR 20 W	20	3/16"	8	0.14	0.6	0.7				●	
	08IR/L 19 W	19	3/16"	8	0.15	0.6	0.7				●	
B/M 	08IR 18 W	18	3/16"	8	0.16	0.6	0.7				●	
	08IR 16 W	16	3/16"	8	0.18	0.6	0.7				●	
	11IR 36 W	36	1/4"	11	0.07	0.6	0.6					
	11IR 28 W	28	1/4"	11	0.10	0.6	0.7	●				
	11IR 26 W	26	1/4"	11	0.10	0.7	0.7				●	●
	11IR/L 24 W	24	1/4"	11	0.11	0.7	0.8	●	●			
	11IR 20 W	20	1/4"	11	0.14	0.8	0.9	●	●			●
	11IR 19 W	19	1/4"	11	0.15	0.8	1.0	●	●			●
	11IR/L 18 W	18	1/4"	11	0.16	0.8	1.0	●	●			●
	11IR 16 W	16	1/4"	11	0.18	0.9	1.1	●	●			●
	11IR/L 14 W	14	1/4"	11	0.21	0.9	1.1	●	●	●		●
	11IL 12 W	12	1/4"	11	0.27	1.0	1.1		●			

• Tolerance: Medium class

●: Standard items

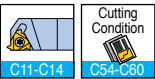

Internal Whitworth

Full profile, BSW, BSF, BSP (B.S. 84-1956 DIN 259)

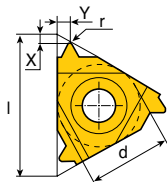

External right hand shown
(Internal left hand)

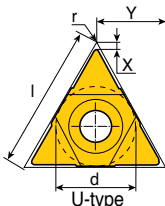

U-type

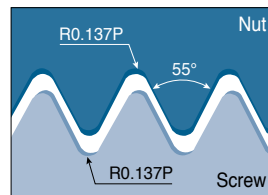

- Application: General industry, fittings and pipe couplings

Insert	Designation	TPI	Dimension (mm)					Coated			Uncoated
			d	l	r	X	Y	TT7010	TT9030	TT8010	P30
Internal	16IR 40 W	40	3/8"	16	0.06	0.6	0.6				•
	16IR/L 32 W	32	3/8"	16	0.09	0.6	0.6				•
Regular	16IR/L 28 W	28	3/8"	16	0.09	0.6	0.7	•			•
	16IR 26 W	26	3/8"	16	0.10	0.7	0.7	•	•		•
B/M	16IR/L 24 W	24	3/8"	16	0.11	0.7	0.8	•	•		•
	16IR/L 22 W	22	3/8"	16	0.13	0.8	0.9	•	•		•
B/M	16IR/L 20 W	20	3/8"	16	0.14	0.8	0.9	•	•		•
	16IRM 20 W	20	3/8"	16	0.14	0.8	0.9		•		
B/M	16IR/L 19 W	19	3/8"	16	0.15	0.8	1.0	•	•		•
	16IRB 19 W	19	3/8"	16	0.15	0.8	1.0		•		
B/M	16IRM 19 W	19	3/8"	16	0.15	0.8	1.0	•			•
	16IR/L 18 W	18	3/8"	16	0.16	0.8	1.0	•	•		•
B/M	16IR/L 16 W	16	3/8"	16	0.18	0.9	1.1				•
	16IRB 16 W	16	3/8"	16	0.18	0.9	1.1		•		
B/M	16IRM 16 W	16	3/8"	16	0.18	0.9	1.1	•	•		•
	16IR/L 14 W	14	3/8"	16	0.21	1.0	1.2	•	•	•	•
B/M	16IRB 14 W	14	3/8"	16	0.21	1.0	1.2		•		
	16IRM 14 W	14	3/8"	16	0.21	1.0	1.2	•	•		•
B/M	16IR/L 12 W	12	3/8"	16	0.25	1.1	1.4	•	•		•
	16IRB 12 W	12	3/8"	16	0.25	1.1	1.4		•		
B/M	16IRM 12 W	12	3/8"	16	0.25	1.1	1.4	•	•	•	•
	16IR/L 11 W	11	3/8"	16	0.27	1.1	1.5	•	•	•	•
B/M	16IRB 11 W	11	3/8"	16	0.27	1.1	1.5		•		
	16IRM 11 W	11	3/8"	16	0.27	1.1	1.5	•			•
B/M	16IR/L 10 W	10	3/8"	16	0.31	1.1	1.5	•	•		•
	16IRB 10 W	10	3/8"	16	0.31	1.1	1.5		•		
B/M	16IR/L 9 W	9	3/8"	16	0.34	1.2	1.7	•			•
	16IRB 9 W	9	3/8"	16	0.34	1.2	1.7				•
B/M	16IR/L 8 W	8	3/8"	16	0.39	1.2	1.5	•	•		•
	22IR 7 W	7	1/2"	22	0.45	1.6	2.3		•		•
B/M	22IR 6 W	6	1/2"	22	0.52	1.6	2.3	•			•
	22IR/L 5 W	5	1/2"	22	0.65	1.7	2.4	•			•
B/M	27IR 4.5 W	4.5	5/8"	27	0.73	1.8	2.6	•			•
	27IR 4 W	4	5/8"	27	0.82	2.0	2.9		•		

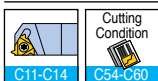

- IRB / IRM with pressed chip breaker
- Tolerance: Medium class

• Standard items

Internal Whitworth

Full profile, BSW, BSF, BSP (B.S. 84-1956 DIN 259)

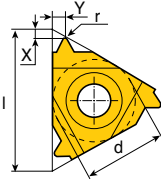

External right hand shown
(Internal left hand)

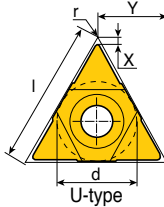

U-type

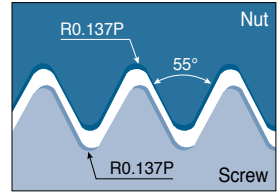

• Application: General industry, fittings and pipe couplings

Insert	Designation	TPI	Dimension (mm)						Coated			Uncoated
			d	l	r	X	Y	TT7010	TT9030	TT8010	P30	
Internal / External  U	08UIRL 12 W	12	3/16"	8	0.25	0.9	4.0				●	
	22UEIRL 4.5 W	4.5	1/2"	22	0.73	2.3	11.0				●	
	22UEIRL 4 W	4	1/2"	22	0.73	1.8	11.0				●	
	27UEIRL 3.5 W	3.5	5/8"	27	0.95	2.1	13.7	●	●			
	27UEIRL 3 W	3	5/8"	27	1.12	2.3	13.7	●				
	27UEIRL 2.75 W	2.75	5/8"	27	1.21	2.4	13.7				●	

• Tolerance: Medium class

●: Standard items

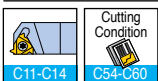

External & Internal NPT

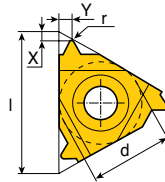

Full profile, national pipe threads (ANSI/ASME B1.20.1-1983)

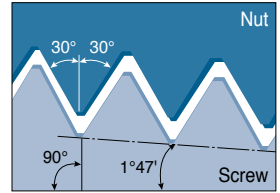

External right hand shown
(Internal left hand)

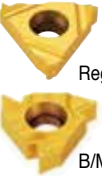

• Application: Steam, gas and water pipes

Insert	Designation	TPI	Dimension (mm)						Coated			Uncoated
			d	l	r	X	Y	TT7010	TT9030	TT8010	P30	
External  Regular B/M	16ER 27 NPT	27	3/8"	16	0.04	0.7	0.8	●	●		●	
	16ER/L 18 NPT	18	3/8"	16	0.06	0.8	1.0	●	●		●	
	16ERB 18 NPT	18	3/8"	16	0.06	0.8	1.0		●			
	16ERM 18 NPT	18	3/8"	16	0.05	0.8	1.0	●	●			
	16ER/L 14 NPT	14	3/8"	16	0.07	0.9	1.2	●	●	●	●	
	16ERB 14 NPT	14	3/8"	16	0.07	0.9	1.2		●			
	16ERM 14 NPT	14	3/8"	16	0.05	0.9	1.2	●	●		●	
	16ER/L 11.5 NPT	11.5	3/8"	16	0.09	1.1	1.5	●	●		●	
	16ERB 11.5 NPT	11.5	3/8"	16	0.09	1.1	1.5		●			
	16ERM 11.5 NPT	11.5	3/8"	16	0.09	1.1	1.5	●	●		●	
	16ER 8 NPT	8	3/8"	16	0.12	1.3	1.8	●	●		●	
	16ERB 8 NPT	8	3/8"	16	0.12	1.3	1.8		●			
16ERM 8 NPT	8	3/8"	16	0.15	1.3	1.8	●	●		●		
Internal  Regular B/M	06IR 27 NPT	27	5/32"	6	0.04	0.6	0.6			●	●	
	08IR 27 NPT	27	3/16"	8	0.04	0.6	0.6			●		
	08IR/L 18 NPT	18	3/16"	8	0.06	0.6	0.6			●	●	
	11IR 27 NPT	27	1/4"	11	0.04	0.7	0.8	●				
	11IR/L 18 NPT	18	1/4"	11	0.06	0.8	1.0	●	●	●		
	11IR/L 14 NPT	14	1/4"	11	0.07	0.8	1.0	●		●		
	16IR 27 NPT	27	3/8"	16	0.04	0.7	0.8		●		●	
	16IR 18 NPT	18	3/8"	16	0.06	0.8	1.0	●	●		●	
	16IR/L 14 NPT	14	3/8"	16	0.07	0.9	1.2	●	●	●	●	
	16IRB 14 NPT	14	3/8"	16	0.07	0.9	1.2		●			
	16IRM 14 NPT	14	3/8"	16	0.05	0.9	1.2	●	●		●	
	16IR/L 11.5 NPT	11.5	3/8"	16	0.09	1.1	1.5	●	●	●	●	
	16IRB 11.5 NPT	11.5	3/8"	16	0.09	1.1	1.5		●			
	16IRM 11.5 NPT	11.5	3/8"	16	0.09	1.1	1.5	●	●		●	
	16IR/L 8 NPT	8	3/8"	16	0.12	1.3	1.8	●	●		●	
	16IRB 8 NPT	8	3/8"	16	0.12	1.3	1.8		●			
16IRM 8 NPT	8	3/8"	16	0.12	1.3	1.8		●				

• ERB / ERM / IRB / IRM with pressed chip breaker

●: Standard items

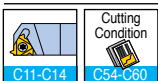

• ERB / ERM / IRB / IRM with pressed chip breaker

●: Standard items

External & Internal NPT

Full profile, multi-tooth, national pipe threads

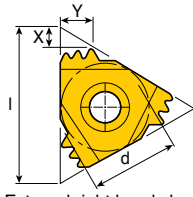

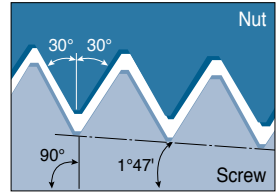

External right hand shown
(Internal left hand)



- Application: Steam, gas and water pipes

Insert	Designation	TPI	Dimension (mm)				No. of teeth	Coated			Uncoated
			d	l	X	Y		TT7010	TT9030	TT8010	P30
Internal / External 	22ER/IR 11.5 NPT 2M	11.5	1/2"	22	2.3	3.5	2		•		
	27ER/IR 11.5 NPT 3M	11.5	5/8"	27	3.3	5.5	3		•		
	27ER/IR 8 NPT 2M	8	5/8"	27	3.1	5.0	2		•		



C11-C14

Cutting Condition
C54-C60

• Standard items

External & Internal NPTF

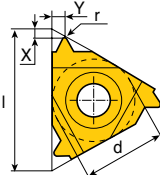

Full profile, national pipe threads-dryseal (ANSI / ASME B1.20.1-1976)

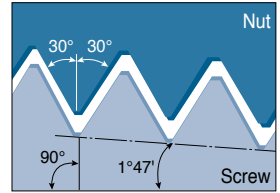

External right hand shown
(Internal left hand)



• Application: Steam, gas and water pipes

Insert	Designation	TPI	Dimension (mm)					Coated			Uncoated
			d	l	r	X	Y	TT7010	TT9030	TT8010	P30
 External Regular	11ER 18 NPTF	18	1/4"	11	0.05	0.8	1.0	•			
	11ER 14 NPTF	14	1/4"	11	0.07	0.8	1.0		•		
	16ER 27 NPTF	27	3/8"	16	0.04	0.7	0.7		•		•
	16ER 18 NPTF	18	3/8"	16	0.06	0.8	1.0		•		
	16ER 14 NPTF	14	3/8"	16	0.07	0.9	1.2	•	•		•
 Internal Regular	16ER 11.5NPTF	11.5	3/8"	16	0.09	1.1	1.5		•		•
	06IR 27 NPTF	27	5/32"	6	0.04	0.7	0.6			•	
	08IR 27 NPTF	27	3/16"	8	0.04	0.6	0.6			•	
	08IR 18 NPTF	18	3/16"	8	0.06	0.6	0.6			•	
	11IR 18 NPTF	18	1/4"	11	0.06	0.8	1.0		•		
	11IR 14 NPTF	14	1/4"	11	0.07	0.8	1.0		•		
	16IR 18 NPTF	18	3/8"	16	0.06	0.8	1.0		•		
	16IR/L 14 NPTF	14	3/8"	16	0.07	0.9	1.2	•	•		
	16IR 11.5NPTF	11.5	3/8"	16	0.09	1.1	1.5	•	•		
	16IR 8 NPTF	8	3/8"	16	0.10	1.3	1.8		•		

•: Standard items

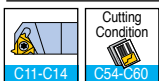

External & Internal BSPT



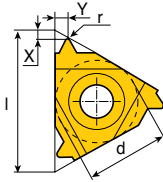

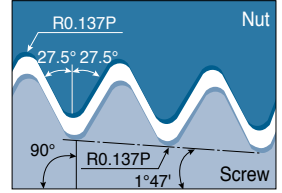

Full profile, british standard pipe (B.S. 21-1957)



External right hand shown
(Internal left hand)



- Application: Steam, gas and water pipes

Insert	Designation	TPI	Dimension (mm)					Coated			Uncoated
			d	l	r	X	Y	TT7010	TT9030	TT8010	P30
External 	16ER 28 BSPT	28	3/8"	16	0.11	0.6	0.6	●	●		
	16ER/L 19 BSPT	19	3/8"	16	0.16	0.8	0.9	●	●		●
	16ER/L 14 BSPT	14	3/8"	16	0.21	1.0	1.2	●	●		●
Regular 	16ERB 14 BSPT	14	3/8"	16	0.21	1.0	1.2		●		
	16ERM 14 BSPT	14	3/8"	16	0.21	1.0	1.2	●	●		
	16ER/L 11 BSPT	11	3/8"	16	0.28	1.1	1.5	●	●		●
B/M 	16ERB 11 BSPT	11	3/8"	16	0.28	1.1	1.5		●		
	16ERM 11 BSPT	11	3/8"	16	0.28	1.1	1.5	●	●		
Internal 	06IR 28 BSPT	28	5/32"	6	0.11	0.7	0.6				●
	08IR 28 BSPT	28	3/16"	8	0.11	0.6	0.6				●
	08IR 19 BSPT	19	3/16"	8	0.16	0.6	0.6				●
Regular 	11IR 19 BSPT	19	1/4"	11	0.16	0.8	0.9	●	●		
	11IR/L 14 BSPT	14	1/4"	11	0.21	0.9	1.0	●	●		
	16IR 28 BSPT	28	3/8"	16	0.11	0.6	0.6	●			
B/M 	16IR 19 BSPT	19	3/8"	16	0.16	0.8	0.9	●			●
	16IR/L 14 BSPT	14	3/8"	16	0.21	1.0	1.2	●	●		●
	16IRB 14 BSPT	14	3/8"	16	0.21	1.0	1.2		●		
	16IRM 14 BSPT	14	3/8"	16	0.21	1.0	1.2		●		
	16IR/L 11 BSPT	11	3/8"	16	0.28	1.1	1.5	●	●	●	●
	16IRB 11 BSPT	11	3/8"	16	0.28	1.1	1.5		●		
	16IRM 11 BSPT	11	3/8"	16	0.28	1.1	1.5		●		

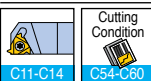

- ERB / ERM / IRB / IRM with pressed chip breaker

- Standard items

External & Internal STUB ACME



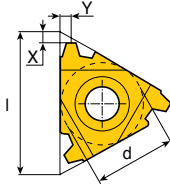

ASME / ANSI B.1.8-1988 class: 2G

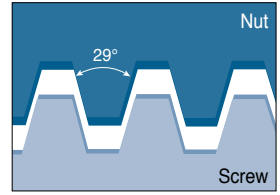

External right hand shown
(Internal left hand)



- Application: Control valves and modified ACME thread forms

Insert	Designation	TPI	Dimension (mm)				Coated			Uncoated	
			d	l	X	Y	TT7010	TT9030	TT8010	P30	
 External Regular	16ER/L 16 STACME	16	3/8"	16	1.0	1.0	●	●		●	
	16ER/L 14 STACME	14	3/8"	16	1.1	1.1				●	
	16ER/L 12 STACME	12	3/8"	16	1.2	1.2	●	●		●	
	16ER/L 10 STACME	10	3/8"	16	1.3	1.3				●	
	16ER/L 8 STACME	8	3/8"	16	1.5	1.5	●	●		●	
	16ER/L 6 STACME	6	3/8"	16	1.8	1.8	●	●			
	22ER/L 5 STACME	5	1/2"	22	2.0	2.3	●	●		●	
	27ER/L 4 STACME	4	5/8"	27	2.3	2.4	●			●	
 Internal Regular	27ER/L 3 STACME	3	5/8"	27	2.8	2.9	●	●	●		
	16IR/L 16 STACME	16	3/8"	16	1.0	1.0				●	
	16IR/L 14 STACME	14	3/8"	16	1.1	1.1				●	
	16IR/L 12 STACME	12	3/8"	16	1.2	1.2	●	●		●	
	16IR/L 10 STACME	10	3/8"	16	1.3	1.3				●	
	16IR/L 8 STACME	8	3/8"	16	1.5	1.5				●	
	16IR/L 6 STACME	6	3/8"	16	1.8	1.8	●	●			
	22IR/L 5 STACME	5	1/2"	22	2.0	2.3	●			●	
	22UIR 3 STACME	3	1/2"	22	3.3	11.0	●				
	27IR/L 4 STACME	4	5/8"	27	2.3	2.4	●	●		●	
27IR/L 3 STACME	3	5/8"	27	2.8	2.9	●					

●: Standard items

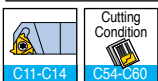

External & Internal ACME

ASME / ANSI B.1.8-1988 class: 3G

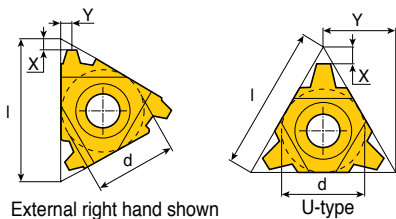

External right hand shown
(Internal left hand)

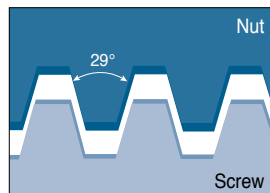

• Application: Feed screws

Insert	Designation	TPI	Dimension (mm)				Coated			Uncoated	
			d	l	X	Y	TT7010	TT9030	TT8010	P30	
 External Regular	11ER 16 ACME	16	1/4"	11	0.9	1.0		•			
	16ER/L 16 ACME	16	3/8"	16	0.9	1.0		•		•	
	16ER/L 14 ACME	14	3/8"	16	1.0	1.2				•	
	16ER/L 12 ACME	12	3/8"	16	1.1	1.2	•	•		•	
	16ER/L 10 ACME	10	3/8"	16	1.3	1.3	•			•	
	16ER/L 8 ACME	8	3/8"	16	1.5	1.5	•	•		•	
	22ER/L 6 ACME	6	1/2"	22	1.8	2.1	•	•		•	
	22ER/L 5 ACME	5	1/2"	22	2.0	2.3	•	•		•	
	22ER/L 4 ACME	4	1/2"	22	2.1	2.2			•		
 Internal Regular	16IR/L 16 ACME	16	3/8"	16	0.9	1.0	•			•	
	16IR/L 14 ACME	14	3/8"	16	1.0	1.2				•	
	16IR/L 12 ACME	12	3/8"	16	1.1	1.2	•	•		•	
	16IR/L 10 ACME	10	3/8"	16	1.3	1.3	•			•	
	16IR/L 8 ACME	8	3/8"	16	1.5	1.5	•	•		•	
	22IR/L 6 ACME	6	1/2"	22	1.8	2.1	•	•		•	
	22IR/L 5 ACME	5	1/2"	22	2.0	2.3	•	•		•	
	22IR 4 ACME	4	1/2"	22	2.1	2.2		•			
	27IR/L 4 ACME	4	5/8"	27	2.3	2.7	•	•	•	•	
 Internal / External U	22UERL 4 ACME	4	1/2"	22	2.3	11		•		•	
	27UERL 3 ACME	3	5/8"	27	2.8	13.7	•	•			
	22UIRL 4 ACME	4	1/2"	22	2.3	11				•	
	27UIRL 3 ACME	3	5/8"	27	2.8	13.7	•	•			

• Standard items

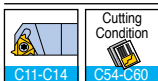

External UNJ

Full profile (MIL-S-8879C 9-1992 class: 3A)

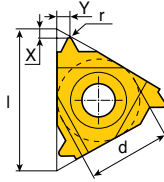

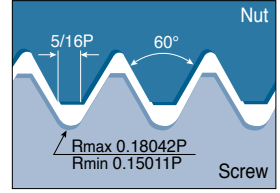

External right hand shown
(Internal left hand)



• Application: Aircraft and aerospace industry

Insert	Designation	TPI	Dimension (mm)					Coated			Uncoated
			d	l	r	X	Y	TT7010	TT9030	TT8010	P30
External 	11ER 28 UNJ	28	1/4"	11	0.14	0.6	0.6		●		
	11ER 24 UNJ	24	1/4"	11	0.16	0.7	0.8		●		
Regular	11ER/L 20 UNJ	20	1/4"	11	0.19	0.8	0.9		●		
	11EL 18 UNJ	18	1/4"	11	0.21	0.8	1.0		●		
	16ER 48 UNJ	48	3/8"	16	0.08	0.6	0.6		●		
	16ER 44 UNJ	44	3/8"	16	0.09	0.6	0.6		●		
	16ER 40 UNJ	40	3/8"	16	0.10	0.6	0.6		●		
	16ER 36 UNJ	36	3/8"	16	0.11	0.6	0.6		●		
	16ER/L 32 UNJ	32	3/8"	16	0.12	0.6	0.6		●		●
	16ER 28 UNJ	28	3/8"	16	0.14	0.6	0.6	●	●		●
	16ER/L 24 UNJ	24	3/8"	16	0.16	0.7	0.8	●	●		●
	16ER/L 20 UNJ	20	3/8"	16	0.19	0.8	0.9	●	●		●
	16ER/L 18 UNJ	18	3/8"	16	0.21	0.8	1.0	●	●		●
	16ER/L 16 UNJ	16	3/8"	16	0.24	0.8	1.0	●	●		●
	16ER/L 14 UNJ	14	3/8"	16	0.27	1.0	1.2	●	●		●
	16ER 13 UNJ	13	3/8"	16	0.29	1.1	1.3		●		●
	16ER/L 12 UNJ	12	3/8"	16	0.32	1.1	1.4	●	●		●
	16ER 11 UNJ	11	3/8"	16	0.35	1.1	1.5		●		●
	16ER 10 UNJ	10	3/8"	16	0.38	1.1	1.5		●		●
	16ER/L 8 UNJ	8	3/8"	16	0.48	1.2	1.6	●			●

●: Standard items

	
C11-C14	C54-C60

Internal UNJ

Full profile

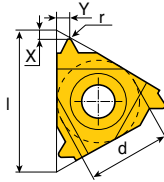

External right hand shown
(Internal left hand)

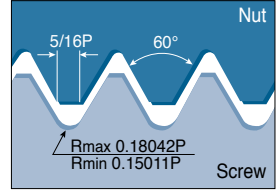

• Application: Aircraft and aerospace industry

Insert	Designation	TPI	Dimension (mm)					Coated			Uncoated
			d	l	r	X	Y	TT7010	TT9030	TT8010	P30
 Regular	08IR 20 UNJ	20	3/16"	8	0.06	0.8	0.9			•	
	08IR 18 UNJ	18	3/16"	8	0.07	0.8	1.0			•	
	11IR 32 UNJ	32	1/4"	11	0.04	0.6	0.6		•		
	11IR 28 UNJ	28	1/4"	11	0.04	0.6	0.6		•		
	11IR 24 UNJ	24	1/4"	11	0.05	0.7	0.8		•		
	11IR 20 UNJ	20	1/4"	11	0.06	0.8	0.9		•		
	11IR 18 UNJ	18	1/4"	11	0.07	0.8	1.0		•		
	11IR 16 UNJ	16	1/4"	11	0.09	0.8	1.0		•		
	16IR 28 UNJ	28	3/8"	16	0.04	0.6	0.6				•
	16IR 24 UNJ	24	3/8"	16	0.05	0.7	0.8				•
	16IR 20 UNJ	20	3/8"	16	0.06	0.8	0.9		•		•
	16IR 18 UNJ	18	3/8"	16	0.07	0.8	1.0				•
	16IR/L 16 UNJ	16	3/8"	16	0.09	0.8	1.0	•	•		•
	16IR 14 UNJ	14	3/8"	16	0.10	1.0	1.2		•		•
	16IR/L 12 UNJ	12	3/8"	16	0.12	1.1	1.4	•	•		•
16IR/L 8 UNJ	8	3/8"	16	0.19	1.2	1.6		•		•	

• Standard items

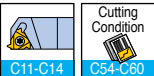

External & Internal MJ

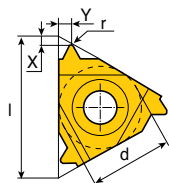

Full profile (ISO 5855)



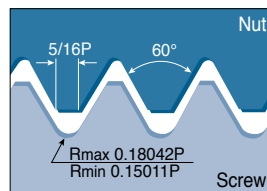

External right hand shown
(Internal left hand)



- Application: Aircraft and aerospace industry

Insert	Designation	Pitch (mm)	Dimension (mm)					Coated			Uncoated
			d	l	r	X	Y	TT7010	TT9030	TT8010	P30
 External	16ER 1.00 MJ	1.00	3/8"	16	0.16	0.7	0.8		●		
	16ER 1.25 MJ	1.25	3/8"	16	0.20	0.8	0.9		●		
	16ER 1.50 MJ	1.50	3/8"	16	0.23	0.8	1.0	●			
	16ER 2.00 MJ	2.00	3/8"	16	0.32	1.0	1.3		●		
 Internal	11IR 1.00 MJ	1.00	1/4"	11	0.05	0.7	0.8		●		
	11IR 1.25 MJ	1.25	1/4"	11	0.07	0.8	0.9		●		
	11IR 1.50 MJ	1.50	1/4"	11	0.08	0.8	1.0		●		
	11IR 2.00 MJ	2.00	1/4"	11	0.12	0.9	1.0		●		
	16IR 1.00 MJ	1.00	3/8"	16	0.05	0.7	0.8		●		
	16IR 1.25 MJ	1.25	3/8"	16	0.07	0.8	0.9		●		
	16IR 1.50 MJ	1.50	3/8"	16	0.08	0.8	1.0		●		

●: Standard items

	
C11-C14	C54-C60

External & Internal Trapez

DIN 103

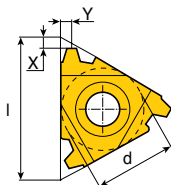

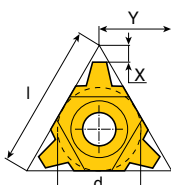

External right hand shown
(Internal left hand)

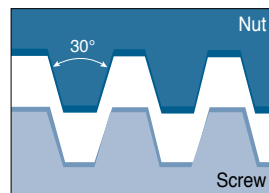

U-type



• Application: Feed screws

Insert	Designation	Pitch (mm)	Dimension (mm)				Coated			Uncoated
			d	l	X	Y	TT7010	TT9030	TT8010	P30
 Regular	16ER/L 1.5 TR	1.5	3/8"	16	1.0	1.1	●	●		●
	16ER/L 2 TR	2.0	3/8"	16	1.0	1.3	●	●		●
	16ER/L 3 TR	3.0	3/8"	16	1.3	1.5	●	●	●	●
	22ER/L 4 TR	4.0	1/2"	22	1.8	1.9	●	●		●
	22ER/L 5 TR	5.0	1/2"	22	2.0	2.4	●	●	●	●
	27ER/L 6 TR	6.0	5/8"	27	2.3	2.7	●	●		
	27ER/L 7 TR	7.0	5/8"	27	2.2	2.6	●	●		
 Regular	08IR/L 1.5 TR⁽¹⁾	1.5	3/16"	8	0.6	0.6			●	
	16IR 1.5 TR	1.5	3/8"	16	1.0	1.1			●	
	16IR/L 2 TR	2.0	3/8"	16	1.0	1.3	●	●		●
	16IR/L 3 TR	3.0	3/8"	16	1.3	1.5	●	●	●	●
	22IR/L 4 TR	4.0	1/2"	22	1.8	1.9	●	●		●
	22IR/L 5 TR	5.0	1/2"	22	2.0	2.4	●	●	●	●
	27IR/L 6 TR	6.0	5/8"	27	2.3	2.7	●	●		
 U	22UERL 6 TR	6.0	1/2"	22	2.0	11.0	●	●	●	●
	22UERL 7 TR	7.0	1/2"	22	2.3	11.0	●			●
	22UERL 8 TR	8.0	1/2"	22	2.5	11.0	●			●
	27UERL 8 TR	8.0	5/8"	27	2.5	13.7	●	●	●	
	27UERL 9 TR	9.0	5/8"	27	3.0	13.7	●	●		
	27UERL 10 TR⁽¹⁾	10.0	5/8"	27	3.2	13.7	●	●		
	08UIRL 2 TR	2.0	3/16"	8	0.9	4.0			●	
	22UIRL 6 TR	6.0	1/2"	22	2.0	11.0	●	●		●
	22UIRL 7 TR	7.0	1/2"	22	2.3	11.0	●			●
	27UIRL 8 TR	8.0	5/8"	27	2.5	13.7	●	●	●	●
	27UIRL 9 TR	9.0	5/8"	27	3.0	13.7	●	●		
	27UIRL 10 TR⁽¹⁾	10.0	5/8"	27	3.2	13.7		●		

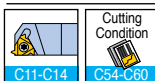

- ⁽¹⁾ One cutting edge only
- DIN 103 04 / 1977, 150 2901 / 1977 Class 7H (7E)

• Standard items

External & Internal PG

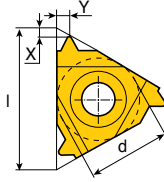

Full profile (DIN 40430)

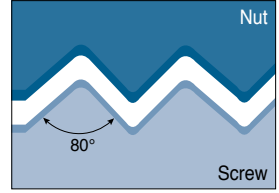

External right hand shown
(Internal left hand)



• Application: Electrical industry

Insert	Designation	Pitch (mm)	Dimension (mm)				Coated			Uncoated
			d	l	X	Y	TT7010	TT9030	TT8010	P30
 External Regular	16ER 16 PG	16	3/8"	16	0.8	1.0		●		●
	16ER 18 PG	18	3/8"	16	0.8	0.9		●		
	16ER 20 PG	20	3/8"	16	0.7	0.8		●		
 Internal Regular	11IR 18 PG	18	1/4"	11	0.8	0.9	●	●		
	16IR/L 16 PG	16	3/8"	16	0.8	1.0		●		●
	16IR 18 PG	18	3/8"	16	0.8	0.9		●		
	16IL 20 PG	20	3/8"	16	0.8	1.0		●		

●: Standard items



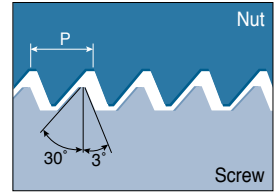
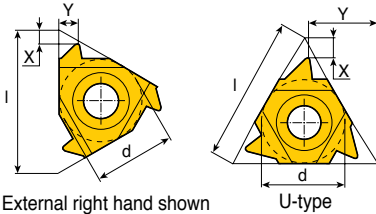

External & Internal Sagengengewinde

T-THREAD

DIN 513



• Application: For high forces in one direction

Insert	Designation	Pitch (mm)	Dimension (mm)				Coated			Uncoated
			d	l	X	Y	TT7010	TT9030	TT8010	P30
 External Regular	16ER/L 2 SAGE	2.0	3/8"	16	1.1	1.6		•		
	22ER/L 3 SAGE	3.0	1/2"	22	1.5	2.4		•		
	22ER/L 4 SAGE	4.0	1/2"	22	1.9	3.1	•	•		
 External U	22UER/L 5 SAGE	5.0 ⁽¹⁾	1/2"	22	1.2	11.6	•	•		
	22UER/L 6 SAGE	6.0 ⁽¹⁾	1/2"	22	1.2	11.7		•		
 Internal Regular	16IR/L 2 SAGE	2.0	3/8"	16	1.2	1.7		•		
	22IR/L 3 SAGE	3.0	1/2"	22	1.9	2.9	•	•		
	22IR 4 SAGE	4.0	1/2"	22	2.3	3.5		•		
 Internal U	22UIR 5 SAGE	5.0 ⁽¹⁾	1/2"	22	1.9	11.7	•	•		
	22UIR 6 SAGE	6.0 ⁽¹⁾	1/2"	22	2.1	11.9		•		

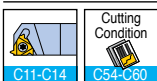

• ⁽¹⁾ Requires special anvil

• Standard items

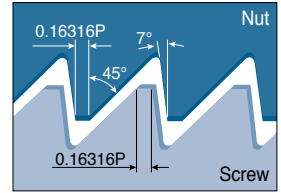
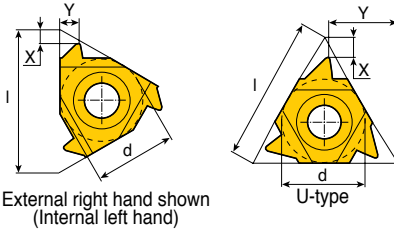

• Application: For high forces in one direction

Insert	Designation	TPI	Dimension (mm)				Coated			Uncoated	
			d	l	X	Y	TT7010	TT9030	TT8010	P30	
 Regular	11ER 20 ABUT	20	1/4"	11	1.0	1.3	●	●			
	11ER 16 ABUT	16	1/4"	11	1.0	1.5					
	16ER 20 ABUT	20	3/8"	16	1.0	1.3		●			
	16ER/L 16 ABUT	16	3/8"	16	1.1	1.5	●	●			
	16ER/L 12 ABUT	12	3/8"	16	1.4	2.0	●	●		●	
	16ER/L 10 ABUT	10	3/8"	16	1.5	2.3		●		●	
	22ER 8 ABUT	8	1/2"	22	2.1	3.3	●				
 U	22ER 6 ABUT	6	1/2"	22	2.1	3.4		●			
	22UER 4 ABUT	4	1/2"	22	2.3	9.5	●			●	
	27UER/L 3 ABUT	3	5/8"	27	3.1	11.7	●	●			
 Regular	11IR 20 ABUT	20	1/4"	11	1.0	1.3		●			
	11IR/L 16 ABUT	16	1/4"	11	1.0	1.5	●	●	●		
	16IR 20 ABUT	20	3/8"	16	1.0	1.3	●	●			
	16IR/L 16 ABUT	16	3/8"	16	1.0	1.5	●	●			
	16IR/L 12 ABUT	12	3/8"	16	1.4	2.0	●	●		●	
	16IR/L 10 ABUT	10	3/8"	16	1.5	2.3	●	●		●	
	22IR 8 ABUT	8	1/2"	22	2.1	3.3		●			
 U	22IR/L 6 ABUT	6	1/2"	22	2.1	3.4		●		●	
	22UIR 4 ABUT	4	1/2"	22	2.3	9.5				●	
	27UIR/L 3 ABUT	3	5/8"	27	3.1	11.7		●			

• ANSI B1.9-1973 class 2

●: Standard items

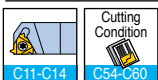

External & Internal Round

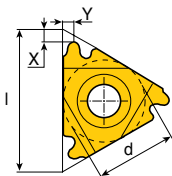

DIN 405

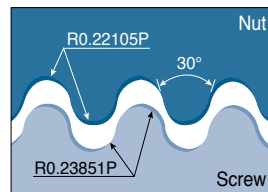

External right hand shown
(Internal left hand)



- Application: Pipe couplings in fire fighting and food industries

Insert	Designation	TPI	Dimension (mm)				Coated			Uncoated
			d	l	X	Y	TT7010	TT9030	TT8010	P30
 External Regular	16ER/L10 RND	10	3/8"	16	1.1	1.2	•	•		•
	16ER/L 8 RND	8	3/8"	16	1.4	1.3	•	•		•
	16ERM 8 RND	8	3/8"	16	1.4	1.3		•		
	16ER/L 6 RND	6	3/8"	16	1.5	1.7	•			•
	16ERM 6 RND	6	3/8"	16	1.5	1.7		•		
	22ER/L 6 RND	6	1/2"	22	1.5	1.7	•	•	•	•
	22ER/L 4 RND	4	1/2"	22	2.2	2.3	•	•		•
	27ER 4 RND	4	5/8"	27	2.2	2.3	•			•
 Internal Regular	16IR 10 RND	10	3/8"	16	1.1	1.2	•	•		•
	16IR/L 8 RND	8	3/8"	16	1.4	1.4	•	•		•
	16IR/L 6 RND	6	3/8"	16	1.4	1.5	•	•	•	
	16IRM 6 RND	6	3/8"	16	1.4	1.5	•	•		•
	22IR 6 RND	6	1/2"	22	1.5	1.7	•	•		•
	22IR/L 4 RND	4	1/2"	22	2.2	2.3	•	•		•
	27IR/L 4 RND	4	5/8"	27	2.2	2.3	•	•		•

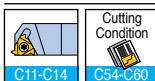

- ERM / IRM with pressed chip breaker
- Tolerance class 7H

• Standard items

API - Oil Threads

T-THREAD

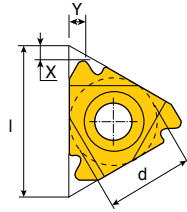

Round profile

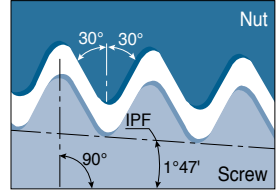

External right hand shown
(Internal left hand)



• Application: Oil & gas industry

Insert	Designation	TPI	Dimension (mm)					Coated			Uncoated
			d	l	IPF	X	Y	TT7010	TT9030	TT8010	P30
 External	16ER 10 API RD	10	3/8"	16	0.75	1.5	1.4	●	●		●
	16ER/L 8 API RD	8	3/8"	16	0.75	1.3	1.6	●	●		●
Regular											
 Internal	16IR/L 10 API RD	10	3/8"	16	0.75	1.5	1.4	●	●	●	●
	16IR/L 8 API RD	8	3/8"	16	0.75	1.3	1.6	●			●
Regular											

●: Standard items

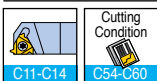

API - Oil Threads

Round profile, multi-tooth

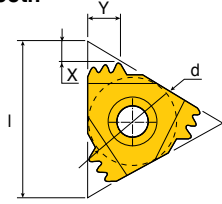

External right hand shown
(Internal left hand)

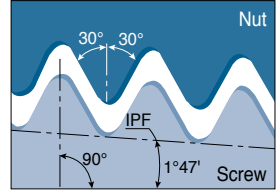

- Application: Oil & gas industry

Insert	Designation	TPI	Dimension (mm)					No. of Teeth	Coated			Uncoated
			d	l	IPF	X	Y		TT7010	TT9030	TT8010	P30
Internal / External 	22ER/IR 10 API RD 2M	10	1/2"	22	0.75	2.4	3.7	2		•		
	27ER/IR 10 API RD 3M	10	5/8"	27	0.75	3.8	6.2	3		•		
	27ER/IR 8 API RD 2M	8	5/8"	27	0.75	3.0	4.5	2		•		

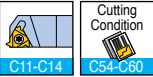

• API Spec 5B8-1996

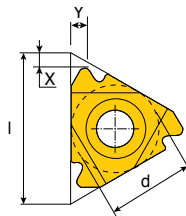

• Standard items

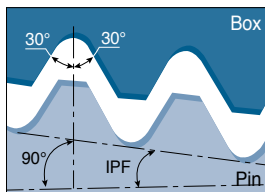

External right hand shown
(Internal left hand)



• Application: Oil & gas industry

Insert	Designation	TPI	Dimension (mm)					Connection No. or size	Coated			Uncoated
			d	l	IPF	X	Y		TT7010	TT9030	TT8010	P30
External 	22ER/L 5 API 403⁽¹⁾	5	1/2"	22	3	1.8	2.5	2.375"-4.5"REG	•	•		•
	27ER/L 4 API 382⁽²⁾	4	5/8"	27	2	2.1	2.8	NC23-NC50	•	•		
	27ER 4 API 383⁽²⁾	4	5/8"	27	3	2.1	2.8	NC56-NC77	•	•		
	27ER/L 4 API 502⁽³⁾	4	5/8"	27	2	2.0	3.0	6-5/8"REG	•	•		•
Regular	27ER 4 API 503⁽³⁾	4	5/8"	27	3	2.0	3.0	5-1/2, 7-5/8, 8-5/8"REG	•	•		•
Internal 	22IR/L 5 API 403⁽¹⁾	5	1/2"	22	3	1.8	2.5	2.375"-4.5"REG	•	•		•
	27IR/L 4 API 382⁽²⁾	4	5/8"	27	2	2.1	2.8	NC23-NC50	•	•		•
	27IR 4 API 383⁽²⁾	4	5/8"	27	3	2.1	2.8	NC56-NC77		•		
	27IR/L 4 API 502⁽³⁾	4	5/8"	27	2	2.0	3.0	6-5/8"REG	•			•
	Regular	27IR/L 4 API 503⁽³⁾	4	5/8"	27	3	2.0	3.0	5-1/2, 7-5/8, 8-5/8"REG	•		



•⁽¹⁾ V-0.040 •⁽²⁾ V-0.038R •⁽³⁾ V-0.050
•0.050, API spec 74-1994

•: Standard items

Buttress Casing / Extreme Line Casing

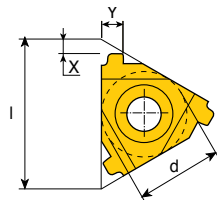

External right hand shown (Internal left hand)

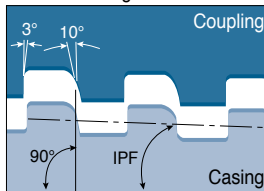

Buttress casing

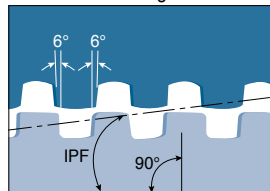

Extreme line casing



• Application: Oil & gas industry

Insert	Designation	TPI	Dimension (mm)					Connection No. or size	Coated			Uncoated
			d	l	IPF	X	Y		TT7010	TT9030	TT8010	
	22ER/IR 5 BUT 0.75	5	1/2"	22	0.75	2.2	2.4	4-1/2" - 13-3/8"	●	●		●
	22ER/IR 5 BUT 1.0	5	1/2"	22	1.0	2.3	2.4	16" - 20"	●			
Buttress												
	22ER 6 EL 1.5	6	1/2"	22	1.5	1.9	1.9	5" - 7-5/8"	●	●		
	22IR 6 EL 1.5	6	1/2"	22	1.5	1.9	1.9	5" - 7-5/8"		●		
	22ER 5 EL 1.25	5	1/2"	22	1.25	2.4	2.3	8-5/8" - 10-3/4"	●	●		
	22IR 5 EL 1.25	5	1/2"	22	1.25	2.4	2.3	8-5/8" - 10-3/4"	●			
Extreme line casing												

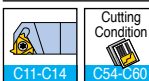

• ANSI B1.9-1973 class 2

• Standard items

Recommended Cutting Conditions

T-THREAD

Machining data for thread turning insert

ISO	Material	Condition	Tensile strength (N/mm ²)	Hardness HB	Material No.	
P	Non-alloy steel, cast steel, free cutting steel	<0.25%C	Annealed	420	125	1
		>=0.25%C	Annealed	650	190	2
		<0.55%C	Quenched and tempered	850	250	3
		>=0.55%C	Annealed	750	220	4
			Quenched and tempered	1000	300	5
	Low alloy steel and cast steel (Less than 5% of alloying elements)		Annealed	600	200	6
				930	275	7
			Quenched and tempered	1000	300	8
				1200	350	9
	High alloy steel, cast steel and tool steel		Annealed	680	200	10
Quenched and tempered			1100	325	11	
M	Stainless steel and cast steel	Ferritic / martensitic	680	200	12	
		Martensitic	820	240	13	
		Austenitic	600	180	14	
K	Gray cast iron (GG)	Ferritic		160	15	
		Pearlitic		250	16	
	Cast iron nodular (GGG)	Ferritic		180	17	
		Pearlitic		260	18	
	Malleable cast iron	Ferritic		130	19	
	Pearlitic		230	20		
N	Aluminum - Wrought alloy	Not cureable		60	21	
		Cured		100	22	
	Aluminum-cast, alloyed	<=12% Si	Not cureable		75	23
			Cured		90	24
		>12% Si	High temp.		130	25
	Copper alloys	>1% Pb	Free cutting		110	26
			Brass		90	27
		Electrolitic copper		100	28	
	Non-metallic		Duroplastics, fiber plastics			29
			Hard rubber			30
S	High temp. alloys	Fe based	Annealed	200	31	
			Cured	280	32	
		Ni or Co based	Annealed	250	33	
			Cured	350	34	
			Cast	320	35	
	Titanium, Ti alloys			Rm 400		36
			Alpha+beta alloys cured	Rm 1050		37
H	Hardened steel	Hardened		55HRC	38	
		Hardened		60HRC	39	
	Chilled cast iron	Cast		400	40	
	Cast iron nodular	Hardened		55HRC	41	

• For more information of material groups, see the materials & grades "material conversion table"

■ Steel
 ■ Stainless steel
 ■ Cast iron
 ■ Nonferrous
 ■ High temp. alloys
 ■ Hardened steel

Recommended Cutting Conditions

Machining data for thread turning insert

Cutting speed (m/min)					
Coated			Uncoated		
TT7010	TT9030	TT8010	P30		
120-200	140-220	85-125	80-120		
120-200	140-220	85-125	80-120		
110-190	130-210	80-120	70-110		
110-190	130-210	80-120	70-110		
90-170	110-190	70-100	65-95		
70-120	70-120	50-70	70-110		
90-170	110-190	70-100	65-95		
80-120	100-140	60-100	70-110		
70-120	90-140	40-80	40-80		
70-100	70-100	40-70	40-70		
40-80	40-80	40-70	40-70		
85-125	90-130	40-70	40-70		
120-180	130-190	80-120	80-120		
50-100	60-110	40-60	40-60		
	100-140	80-120			
	110-150	80-120			
	110-150	80-120			
	80-120	80-120			
	110-150	60-100			
	80-120	55-95			
	1300-1500	700-900			
	400-600	330-430			
	500-800	350-450			
	370-470	300-360			
	200-280	150-210			
	260-340	160-240			
	350-450	250-310			
	100-140	80-120			
	250-350	160-200			
	250-350	150-210			
	50-70	20-50			
	30-50	20-50			
	30-50	20-40			
	20-40	15-30			
	20-40	15-30			
	120-140	90-110			
	40-60	20-50			
	30-60	20-35			
	20-40	20-30			
	20-40	20-30			
	20-30	15-25			

► **Maximum depth of first cut for CNC control / external threading
- M-type inserts**

Full profile	Pitch		Insert designation	No. of passes		Max. depth for first pass (D ₁) mm	
	mm	TPI		Min.	Max.	Low carbon steel	
						Eq. ⁽²⁾	Dim. ⁽³⁾
ISO metric	1.00		16 ERM 1.00 ISO	5	9	0.34	0.51
	1.25		16 ERM 1.25 ISO	6	11	0.42	0.63
	1.50		16 ERM 1.50 ISO	6	12	0.46	0.69
	1.75		16 ERM 1.75 ISO	8	13	0.48	0.72
	2.00		16 ERM 2.00 ISO	8	14	0.50	0.75
	2.50		16 ERM 2.50 ISO	10	15	0.53	0.80
	3.00		16 ERM 3.00 ISO	12	17	0.56	0.84
American UN		24	16 ERM 24 UN	5	9	0.34	0.51
		20	16 ERM 20 UN	6	10	0.42	0.63
		18	16 ERM 18 UN	6	11	0.46	0.69
		16	16 ERM 16 UN	7	12	0.47	0.71
		14	16 ERM 14 UN	6	13	0.46	0.69
		12	16 ERM 12 UN	8	14	0.50	0.75
		8	16 ERM 8 UN	12	17	0.56	0.84
British BSW		19	16 ERM 19 W	6	11	0.35	0.52
		16	16 ERM 16 W	7	12	0.47	0.71
		14	16 ERM 14 W	8	13	0.50	0.75
		11	16 ERM 11 W	9	14	0.44	0.66
NPT		18	16 ERM 18 NPT	10	20	0.24	0.36
		14	16 ERM 14 NPT	13	26	0.24	0.36
		11.5	16 ERM 11.5 NPT	15	24	0.27	0.40
		8	16 ERM 8 NPT	17	30	0.31	0.46
Round		6	16 ERM 6 RND	9	20	0.42	0.63
Partial profile 60°	48-16		16 ERM A 60	(1)		0.22	0.33
	14-8		16 ERM G 60		0.50	0.75	
	48-8		16 ERM AG 60		0.24	0.36	
	7-5		16 ERM N 60		0.41	0.62	
Partial profile 55°	14-8		16 ERM G 55		0.50	0.75	
	48-8		16 ERM AG 55		0.22	0.33	

• ⁽¹⁾ As per the number of passes for the relevant pitch

⁽²⁾ Equal depth of cut method

⁽³⁾ Diminished depth of cut for each pass method

Max. depth for first pass (D1) mm							
High carbon steel		Alloy steel		Stainless steel		Nonferrous aluminum	
Eq. ⁽²⁾	Dim. ⁽³⁾	Eq. ⁽²⁾	Dim. ⁽³⁾	Eq. ⁽²⁾	Dim. ⁽³⁾	Eq. ⁽²⁾	Dim. ⁽³⁾
0.31	0.46	0.27	0.41	0.22	0.33	0.48	0.71
0.38	0.57	0.34	0.50	0.27	0.41	0.59	0.88
0.41	0.62	0.37	0.55	0.30	0.45	0.64	0.97
0.43	0.65	0.38	0.58	0.31	0.47	0.67	1.01
0.45	0.68	0.40	0.60	0.33	0.49	0.70	1.05
0.48	0.72	0.42	0.64	0.34	0.52	0.74	1.12
0.50	0.76	0.45	0.67	0.36	0.55	0.78	1.18
0.31	0.46	0.27	0.41	0.22	0.33	0.48	0.71
0.38	0.57	0.34	0.50	0.27	0.41	0.59	0.88
0.41	0.62	0.37	0.55	0.30	0.45	0.64	0.97
0.42	0.64	0.38	0.57	0.31	0.46	0.66	0.99
0.41	0.62	0.37	0.55	0.28	0.41	0.64	0.97
0.45	0.68	0.40	0.60	0.33	0.49	0.70	1.05
0.50	0.76	0.45	0.67	0.36	0.55	0.78	1.18
0.32	0.47	0.28	0.42	0.21	0.31	0.49	0.73
0.42	0.64	0.38	0.57	0.31	0.46	0.66	0.99
0.45	0.68	0.40	0.60	0.33	0.49	0.70	1.05
0.40	0.59	0.35	0.53	0.29	0.43	0.62	0.92
0.22	0.32	0.19	0.29	0.16	0.23	0.34	0.50
0.22	0.32	0.19	0.29	0.14	0.22	0.34	0.50
0.24	0.36	0.22	0.32	0.18	0.26	0.38	0.56
0.28	0.41	0.25	0.37	0.20	0.30	0.43	0.64
0.38	0.57	0.34	0.50	0.27	0.41	0.59	0.88
0.20	0.30	0.18	0.26	0.14	0.21	0.31	0.46
0.45	0.68	0.40	0.60	0.33	0.49	0.70	1.05
0.22	0.32	0.19	0.29	0.16	0.23	0.34	0.50
0.37	0.56	0.33	0.50	0.27	0.40	0.57	0.87
0.45	0.68	0.40	0.60	0.33	0.49	0.70	1.05
0.20	0.30	0.18	0.26	0.14	0.21	0.31	0.46

▶ Maximum depth of first cut for CNC control / internal threading - M-type inserts

Full profile	Pitch		Insert designation	No. of passes		Max. depth for first pass (D1) mm	
	mm	TPI		Min.	Max.	Low carbon steel	
						Eq. ⁽²⁾	Dim. ⁽³⁾
ISO metric	1.50		11 IRM 1.50 ISO	10	20	0.20	0.30
	1.00		16 IRM 1.00 ISO	9	16	0.14	0.20
	1.25		16 IRM 1.25 ISO	9	16	0.19	0.28
	1.50		16 IRM 1.50 ISO	10	20	0.20	0.30
	1.75		16 IRM 1.75 ISO	11	18	0.21	0.32
	2.00		16 IRM 2.00 ISO	12	21	0.22	0.33
	2.50		16 IRM 2.50 ISO	14	21	0.23	0.34
	3.00		16 IRM 3.00 ISO	16	22	0.24	0.35
American UN		20	16 IRM 20 UN	7	13	0.20	0.30
		18	16 IRM 18 UN	8	15	0.20	0.30
		16	16 IRM 16 UN	11	19	0.20	0.30
		14	16 IRM 14 UN	11	20	0.21	0.31
		12	16 IRM 12 UN	12	21	0.23	0.34
		8	16 IRM 8 UN	14	20	0.24	0.36
British BSW		19	16 IRM 19 W	7	12	0.28	0.42
		16	16 IRM 16 W	9	14	0.26	0.39
		14	16 IRM 14 W	10	16	0.27	0.41
		11	16 IRM 11 W	12	19	0.31	0.46
NPT		14	16 IRM 14 NPT	21	35	0.13	0.20
		11.5	16 IRM 11.5 NPT	21	33	0.17	0.25
		8	16 IRM 8 NPT	20	34	0.23	0.34
Round		6	16 IRM 6 RND	12	24	0.30	0.46
Partial profile 60°		48-16	06 IRM A 60	(1)		0.22	0.33
		48-16	08 IRM A 60		0.13	0.20	
		48-16	11 IRM A 60		0.13	0.20	
		48-16	16 IRM A 60		0.13	0.20	
		14-8	16 IRM G 60		0.22	0.33	
		48-8	16 IRM AG 60		0.14	0.21	
		7-5	22 IRM N 60		0.23	0.34	
Partial profile 55°		14-8	16 IRM G 55		0.34	0.50	
		48-8	16 IRM AG 55		0.14	0.20	

• ⁽¹⁾ As per the number of passes for the relevant pitch

⁽²⁾ Equal depth of cut method

⁽³⁾ Diminished depth of cut for each pass method

▶ Number of cutting passes for regular type inserts

Pitch	mm	0.5	1.0	1.5	2.0	2.5	3.0	4.0	6.0
	TPI	48	24	16	12	10	8	6	4
Number of passes		4-6	5-9	5-12	6-14	7-15	8-17	10-20	11-22

• For mini-tools (06IR or 08IR) add 1-3 passes. Increase for hard materials

Max. depth for first pass (D ₁) mm							
High carbon steel		Alloy steel		Stainless steel		Nonferrous aluminum	
Eq. ⁽²⁾	Dim. ⁽³⁾	Eq. ⁽²⁾	Dim. ⁽³⁾	Eq. ⁽²⁾	Dim. ⁽³⁾	Eq. ⁽²⁾	Dim. ⁽³⁾
0.18	0.27	0.16	0.24	0.12	0.18	0.28	0.42
0.13	0.18	0.11	0.16	0.09	0.13	0.20	0.28
0.17	0.25	0.15	0.22	0.12	0.18	0.27	0.39
0.18	0.27	0.16	0.24	0.12	0.18	0.28	0.42
0.19	0.29	0.17	0.26	0.14	0.21	0.29	0.45
0.20	0.30	0.18	0.26	0.14	0.21	0.31	0.46
0.21	0.31	0.18	0.27	0.15	0.22	0.32	0.48
0.22	0.32	0.19	0.29	0.16	0.23	0.34	0.50
0.18	0.27	0.16	0.24	0.12	0.18	0.28	0.42
0.18	0.27	0.16	0.24	0.12	0.18	0.28	0.42
0.18	0.27	0.16	0.24	0.13	0.20	0.28	0.42
0.19	0.28	0.17	0.25	0.13	0.19	0.29	0.43
0.21	0.31	0.18	0.27	0.15	0.22	0.32	0.48
0.22	0.32	0.19	0.29	0.16	0.23	0.34	0.50
0.25	0.38	0.22	0.34	0.17	0.25	0.39	0.59
0.23	0.35	0.21	0.31	0.17	0.25	0.36	0.55
0.24	0.37	0.22	0.33	0.18	0.27	0.38	0.57
0.28	0.41	0.25	0.37	0.20	0.30	0.43	0.64
0.12	0.18	0.10	0.16	0.08	0.12	0.18	0.28
0.15	0.23	0.14	0.20	0.11	0.16	0.24	0.35
0.21	0.31	0.18	0.27	0.14	0.20	0.32	0.48
0.27	0.41	0.24	0.37	0.20	0.30	0.42	0.64
0.20	0.30	0.18	0.26	0.14	0.21	0.31	0.46
0.12	0.18	0.10	0.16	0.08	0.13	0.18	0.28
0.12	0.18	0.10	0.16	0.08	0.13	0.18	0.28
0.12	0.18	0.10	0.16	0.08	0.13	0.18	0.28
0.20	0.30	0.18	0.26	0.14	0.21	0.31	0.46
0.13	0.19	0.11	0.17	0.09	0.14	0.20	0.29
0.21	0.31	0.18	0.27	0.15	0.22	0.32	0.48
0.31	0.45	0.27	0.40	0.22	0.33	0.48	0.70
0.13	0.18	0.11	0.16	0.09	0.13	0.20	0.28

► Recommended number of passes for multi-tooth insert

Full profile	Insert description	No. of passes	1 st pass	2 nd pass	3 rd pass	4 th pass	External / internal
ISO metric	16 ER 1.0 ISO 3M	2	0.39	0.24	-	-	External
	16 ER 1.5 ISO 2M	3	0.40	0.31	0.21	-	External
	22 ER 1.5 ISO 3M	2	0.54	0.38	-	-	External
	22 ER 2.0 ISO 2M	3	0.56	0.42	0.27	-	External
	22 ER 2.0 ISO 3M	2	0.75	0.50	-	-	External
	27 ER 3.0 ISO 2M	4	0.60	0.52	0.44	0.30	External
	16 IR 1.0 ISO 3M	2	0.32	0.26	-	-	Internal
	16 IR 1.5 ISO 2M	3	0.36	0.29	0.22	-	Internal
	22 IR 1.5 ISO 3M	2	0.49	0.38	-	-	Internal
	22 IR 2.0 ISO 2M	3	0.50	0.40	0.25	-	Internal
	22 IR 2.0 ISO 3M	2	0.72	0.43	-	-	Internal
	27 IR 3.0 ISO 2M	4	0.57	0.45	0.38	0.33	Internal
UN	16 ER 16 UN 2M	3	0.45	0.32	0.20	-	External
	22 ER 16 UN 3M	2	0.60	0.37	-	-	External
	22 ER 12 UN 2M	3	0.60	0.39	0.31	-	External
	22 ER 12 UN 3M	2	0.80	0.50	-	-	External
	27 ER 8 UN 2M	4	0.63	0.55	0.42	0.36	External
	16 IR 16 UN 2M	3	0.40	0.29	0.23	-	Internal
	22 IR 16 UN 3M	2	0.57	0.35	-	-	Internal
	22 IR 12 UN 2M	3	0.55	0.39	0.28	-	Internal
	22 IR 12 UN 3M	2	0.75	0.47	-	-	Internal
	27 IR 8 UN 2M	4	0.65	0.49	0.42	0.27	Internal
NPT	22 ER 11.5 NPT 2M	4	0.55	0.46	0.35	0.32	External
	27 ER 11.5 NPT 3M	3	0.75	0.57	0.36	-	External
	27 ER 8 NPT 2M	4	0.80	0.62	0.54	0.45	External
	22 IR 11.5 NPT 2M	4	0.55	0.46	0.35	0.32	Internal
	27 IR 11.5 NPT 3M	3	0.75	0.57	0.36	-	Internal
	27 IR 8 NPT 2M	4	0.80	0.62	0.54	0.45	Internal
Whitworth	16 ER 14 W 2M	3	0.51	0.39	0.26	-	External
	22 ER 14 W 3M	2	0.72	0.44	-	-	External
	22 ER 11 W 2M	3	0.65	0.46	0.37	-	External
	16 IR 14 W 2M	3	0.51	0.39	0.26	-	Internal
	22 IR 14 W 3M	2	0.72	0.44	-	-	Internal
	22 IR 11 W 2M	3	0.65	0.46	0.37	-	Internal
API round	22 ER 10 API RD 2M	3	0.58	0.53	0.30	-	External
	27 ER 10 API RD 3M	2	0.98	0.43	-	-	External
	27 ER 8 API RD 2M	3	0.82	0.59	0.40	-	External
	22 IR 10 API RD 2M	3	0.58	0.53	0.30	-	Internal
	27 IR 10 API RD 3M	2	0.98	0.43	-	-	Internal
	27 IR 8 API RD 2M	3	0.82	0.59	0.40	-	Internal