

Ürün Kataloğu

Production Catalog

www.vorgen.com



 **VORGEN**[®]

The red power for
the professionals
Profesyoneller için
Kırmızı Güç

 **VORGEN®**

The **red** power for
the professionals
Profesyoneler için
Kırmızı Güç



The red power for
the professionals
Profesyoneller için
Kırmızı Güç



HAKKIMIZDA / ABOUT

1975 yılında Talaşlı imalat faaliyetiyle sektöre adım atan BAHÇIVAN makine , 1988 yılında sektörde oluşan torna kateri talebi karşısında emek ve yatırımlarını bu doğrultuda kanallize ederek Kesici Uç Bağlama Sistemleri üretimine başlamış. 1996 yılında piyasada oluşan yeni talepleri karşılamak, ürün hassasiyetini en üst düzeye çıkarmak, geriye- ileriye bütünlük üretim yapmak amacıyla son teknoloji CNC tezgahlarını makine parkuruna dahil etmiştir.

35 yıla yakın zamanı geride bırakan Bahçivan Makine 1000 m2 ye yakın kapalı alanı, otomasyon destekli cnc makineleri, kalifeye ekibi ile Talaşlı İmalat sektöründe kullanılan kesici uç bağlama sistemleri üreten lider firmalar arasında yüzde 100 yerli üretimle üreterek ülke ekonomisine ve sanayisine katkıda bulunmakta, Sürekli öğrenen ve gelişen organizasyon yapısı ile üretimde sürekli iyileştirmeyi hedef almakta, Yönetim ve Üretimini ISO 9001:2000 kalite yönetim sistemiyle güçlendirip yurt içi ve yurt dışı pazarında önemli rol üstlenmektedir.

Ve bugün, Bahçivan Makine bu anlayışla, müşteri ve tedarikçilerinden gelen feedback leri değerlendirerek ürün çeşitliliği ve toplam kalite anlayışıyla öncü konuma gelmenin, yurt içi ve yurt dışı pazarlarda aranılan marka haline gelmenin haklı gururunu siz değerli müşterilerimizle ve tedarikçilerimizle paylaşmaktayız.

BAHCIVAN Makine stepped into the sector with Talasli manufacturing in 1975. It transferred its labour and investments to meet latle tool demand in 1988 and started the manufacturing of cutting edge tie down systems. It incorporated CNC counters With latest technology into its machinery in 1996 to meet incoming demands of market, to raise the product sensitivity to the top level and to realize integrated production backwards and froward.

Bahcivan Makine has a history of more than 35 years. It has a closed area of 1000m2, automation assisted CNC machinery and a qualified team. It has been contributing to the conomy and industry of the country with a 100% domestic production among prominent companies of cutting adge tie down system utilized in Talasli manufacturing system.

Bahcivan Makine aims constand improvement in production with its constantly learning and developing organization structure. Its shoulders an important role in internal and external markets by strengthening its management and production through ISO 9001 :2000 quality management system. Today through this point io view and feedbacks of customers and suppliers and with its production varieth and total quality approach, Bahcivan Makina shares the rightful honour with its honorable customers and suppliers, of being a Pioneer in its sector and a desired brand in internal and external markets.

SERTİFİKALAR / CERTIFICATES



10-18	D SİSTEM DIŞ TORNA KATERLERİ / D SYSTEM EXTERNAL LATHE TOOLHOLDERS
20-21	M SİSTEM DIŞ TORNA KATERLERİ / M SYSTEM EXTERNAL LATHE TOOLHOLDERS
23-25	C SİSTEM DIŞ TORNA KATERLERİ / C SYSTEM EXTERNAL LATHE TOOLHOLDERS
28-37	S SİSTEM DIŞ TORNA KATERLERİ / S SYSTEM EXTERNAL LATHE TOOLHOLDERS
39	P SİSTEM DIŞ TORNA KATERLERİ / P SYSTEM EXTERNAL LATHE TOOLHOLDERS
40-41	TIRTIR DIŞ TORNA KATERLERİ / INCHINEMUON CLAMP OUTSIDE DIAMETER
44-48	D SİSTEM DELİK TORNA KATERLERİ / D SYSTEM BORING BARS
50-52	M SİSTEM DELİK TORNA KATERLERİ / M SYSTEM BORING BARS
54	C SİSTEM DELİK TORNA KATERLERİ / C SYSTEM BORING BARS
56-64	S SİSTEM DELİK TORNA KATERLERİ / S SYSTEM BORING BARS
66-67	VİDA TAKIMLARI / SCREW PLUGS
70-84	DIŞ ÇAP KANAL AÇMA TAKIMLARI / EXTERNAL GROOVING TOOLHOLDERS
86-87	DIŞ ÇAP ALIN KANAL AÇMA TAKIMLARI / FACE EXTERNAL GROOVING TOOLHOLDERS
88-91	DELİK İÇİ KANAL TAKIMLARI / INTERNAL GROOVING TOOLHOLDERS
92-93	PAH FREZELER / CHAMFERING END MILLS
96-122	FREZE TAKIMLARI / MILLS TOOLS
124-137	PARMAK FREZELER / MILLING TOOLS
138-140	MODULER FREZELER / MODULAR END MILLS
142-157	DELİK DELME TORNALAMA TAKIMLARI / DRILLING BORING END EXTERNAL TURNING
158-159	DİSK FREZE - T FREZE / DISC END T MILLING
160	ISO / ISO
162-168	YEDEK PARÇALAR / SPARE PARTS

External Turning
Code Key

Extract from ISO

D	W	L	N	R	25	25	M	08
1	2	3	4	5	6	7	8	9

1 Clamping System Top Clamping (C), Top and hole clamping (D), Wedge clamping (M), Lever Clamping (P), Screw Clamping (S)					2 Insert Shape C (80°), E (75°), D (55°), K (55°), R (Circle), S (Square), T (Triangle), V (35°), W (80°)			
3 Approach Angle A (90°), B (75°), D (45°), E (60°), F (90°), G (90°), H (107.5°), J (93°), K (75°), L (95°), N (63°), P (117.5°), Q (107.5°), R (75°), S (45°), T (60°), U (93°), V (72.5°)						4 Insert Clearance Angle A (3°), B (5°), C (7°), D (15°), E (20°), F (25°), G (30°), N (0°), P (11°)		
5 Hand of Tool L, N, R		6 Shank Height h mm 8 = 08 mm, 16 = 16 mm, 25 = 25 mm		7 Shank Width b mm 8 = 08 mm, 16 = 16 mm, 25 = 25 mm				
8 Tool Length L mm A=32, B=40, C=50, D=60, F=80, H=100, K=125, L=140, M=150, N=160, P=170, Q=180, R=200, S=250, T=300, U=350, V=400, W=450, Y=500, X=Special						9 Cutting edge length mm C, E, D, K, R, S, T, V, W		

The red power for the professional
Profesyoneler için
Kırmızı Güç



D SİSTEM DIŞ TORNALATERLERİ
D System external lathe tool holders

www.vorgen.com

DDJNR ÜRÜN / PRODUCT 93°

TEKNİK ÇİZİM / TECHNICAL DRAWING

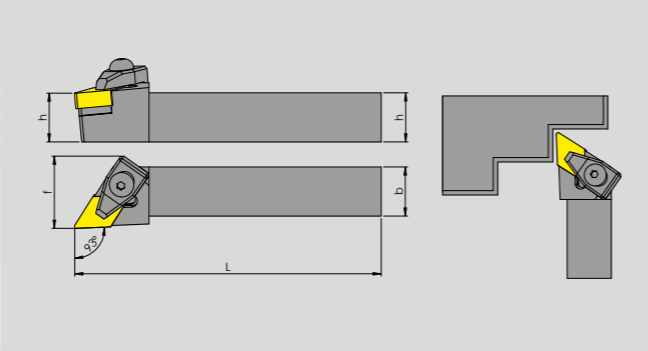

TAKIM KODU ORDERING CODE	KATER ÖLÇÜLERİ DIMENSIONS (mm)				KESİCİ UÇ INSERT	YEDEK PARÇALAR / SPARE PARTS						
	h	b	L	f		BASKI PARÇASI WEDGE CLAMP	BASKI VIDASI SCREW	ALTLIK SHIM	ALTLIK VIDASI SHIM SCREW	YAY SPRING	ANAHTAR ALLEN KEY	
DDJNR/L 1616	H11	16	16	100	20	DNM.. 11 04..	VDP 01	VRV 01 M5	VRDN 1	VAV 03 M4	VRY 01	AA3
DDJNR/L 2020	K11	20	20	125	25							
DDJNR/L 2525	M11	25	25	150	32	DNM.. 15 16..	VDP 02	VRV 02 M6	VRDN 15	VAV 02 M5	VRY 01	AA3
DDJNR/L 2020	K15	20	20	125	25							
DDJNR/L 2525	M15	25	25	150	32							
DDJNR/L 3232	P15	32	32	170	40							
DDJNR/L 4040	S15	40	40	250	50							

DDNNN ÜRÜN / PRODUCT 62,5°

TEKNİK ÇİZİM / TECHNICAL DRAWING

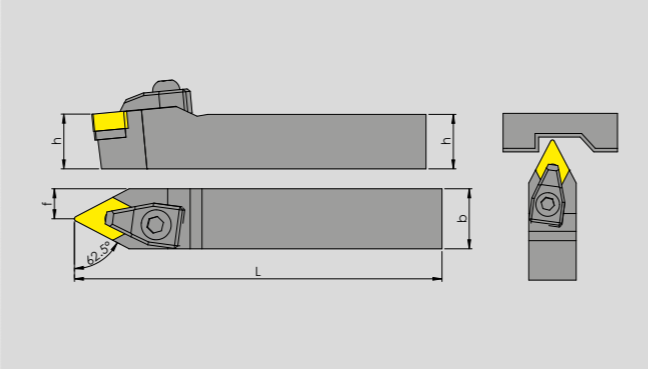

TAKIM KODU ORDERING CODE	KATER ÖLÇÜLERİ DIMENSIONS (mm)				KESİCİ UÇ INSERT	YEDEK PARÇALAR / SPARE PARTS						
	h	b	L	f		BASKI PARÇASI WEDGE CLAMP	BASKI VIDASI SCREW	ALTLIK SHIM	ALTLIK VIDASI SHIM SCREW	YAY SPRING	ANAHTAR ALLEN KEY	
DDNNN 2020	K 15	20	20	125	10	DNM.. 15 06..	VDP 02	VRV 02 M6	VRDN 15	VAV 02 M5	VRY 01	AA3
DDNNN 2525	M 15	25	25	150	12,5							
DDNNN 3232	P 15	32	32	170	16	DNM.. 11 04..	VDP 01	VRV 01 M5	VRDN 11	VAV 03 M5	VRY 01	AA3
DDNNN 2525	M 11	25	25	150	12,5							
DDNNN 2020	K 11	20	20	125	10							

DDHNR ÜRÜN / PRODUCT 107,5°

TEKNİK ÇİZİM / TECHNICAL DRAWING

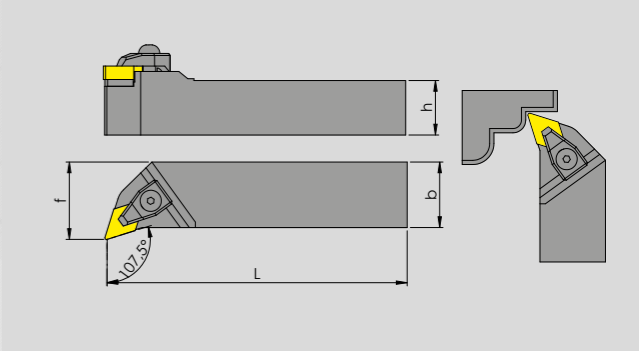

TAKIM KODU ORDERING CODE	KATER ÖLÇÜLERİ DIMENSIONS (mm)				KESİCİ UÇ INSERT	YEDEK PARÇALAR / SPARE PARTS						
	h	b	L	f		BASKI PARÇASI WEDGE CLAMP	BASKI VIDASI SCREW	ALTLIK SHIM	ALTLIK VIDASI SHIM SCREW	YAY SPRING	ANAHTAR ALLEN KEY	
DDHNR/L 2020	K 15	20	20	125	25	DNM.. 15 06..	VDP 02	VRV 02 M6	VRDN 15	VAV 02 M5	VRY 01	AA3
DDHNR/L 2525	M 15	25	25	150	32							
DDHNR/L 3232	P 15	32	32	170	40							

DCLNR ÜRÜN / PRODUCT 95°

TEKNİK ÇİZİM / TECHNICAL DRAWING

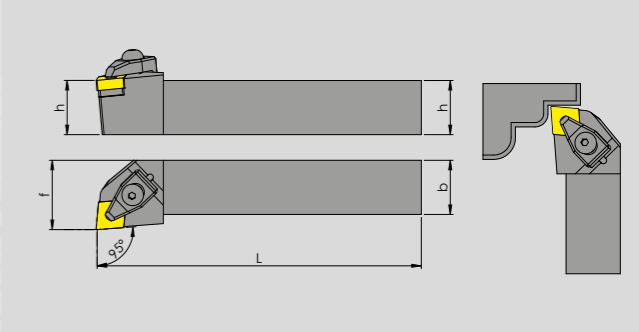

TAKIM KODU ORDERING CODE	KATER ÖLÇÜLERİ DIMENSIONS (mm)				KESİCİ UÇ INSERT	YEDEK PARÇALAR / SPARE PARTS						
	h	b	L	f		BASKI PARÇASI WEDGE CLAMP	BASKI VIDASI SCREW	ALTLIK SHIM	ALTLIK VIDASI SHIM SCREW	YAY SPRING	ANAHTAR ALLEN KEY	
DCLNR/L 2020	K 12	20	20	125	25	CNM.. 12 04..	VDP 02	VRV 02 M6	VRCN 12	VAV 02 M5	VRY 01	AA3
DCLNR/L 2525	M 12	25	25	150	32							
DCLNR/L 3232	P 12	32	32	170	40	CNM.. 16 06..	VDP 04	VRV 03 M6	VRCN 16	VAV 04 M5	VRY 02	AA4
DCLNR/L 2525	M 16	25	25	150	32							
DCLNR/L 3232	P 16	32	32	170	40							
DCLNR/L 4040	S 16	40	40	250	50	CNM.. 19 06..	VDP 05	VRV 03 M6	VRCN 19	VAV 05 M6	VRY 02	AA4
DCLNR/L 2525	M 19	25	25	150	32							
DCLNR/L 3232	P 19	32	32	170	40							
DCLNR/L 4040	S 19	40	40	250	50							

DCXNN ÜRÜN / PRODUCT 40°

TEKNİK ÇİZİM / TECHNICAL DRAWING

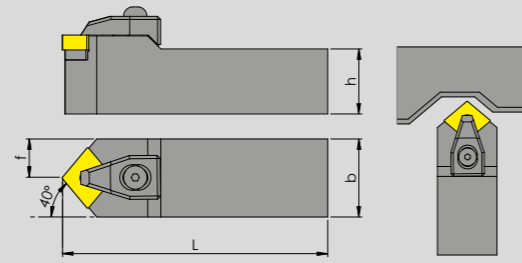

TAKIM KODU ORDERING CODE			KATER ÖLÇÜLERİ DIMENSIONS (mm)				KESİCİ UÇ INSERT	YEDEK PARÇALAR / SPARE PARTS					
								BASKI PARÇASI WEDGE CLAMP	BASKI VİDASI SCREW	ALTLIK SHIM	ALTLIK VİDASI SHIM SCREW	YAY SPRING	ANAHTAR ALLEN KEY
DCXNN	2020	K 12	20	20	125	10	CNM.. 12 04..	VDP 02	VRV 02 M6	VRCN 12	VAV 02 M5	VRY 01	AA3
DCXNN	2525	M 12	25	25	150	12,5							
DCXNN	3232	P 12	32	32	170	16							
DCXNN	2525	M 16	25	25	150	12,5	CNM.. 16 06..	VDP 04	VRV 03 M6	VRCN 16	VAV 04 M5	VRY 02	AA4
DCXNN	3232	P 16	32	32	170	16							

DCKNR ÜRÜN / PRODUCT 75°

TEKNİK ÇİZİM / TECHNICAL DRAWING

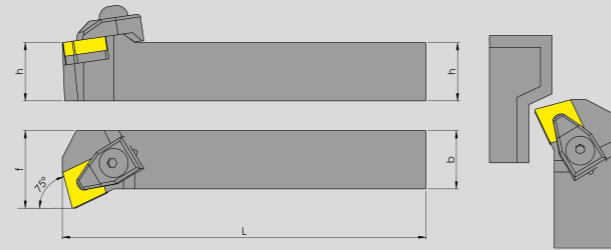

TAKIM KODU ORDERING CODE			KATER ÖLÇÜLERİ DIMENSIONS (mm)				KESİCİ UÇ INSERT	YEDEK PARÇALAR / SPARE PARTS					
								BASKI PARÇASI WEDGE CLAMP	BASKI VİDASI SCREW	ALTLIK SHIM	ALTLIK VİDASI SHIM SCREW	YAY SPRING	ANAHTAR ALLEN KEY
DCKNR/L	2020	K 12	20	20	125	25	CNM.. 12 04..	VDP 02	VRV 02 M6	VRCN 12	VAV 02 M5	VRY 01	AA3
DCKNR/L	2525	M 12	25	25	150	32							
DCKNR/L	3232	P 12	32	32	170	40							
DCKNR/L	2525	M 16	25	25	150	32	CNM.. 16 06..	VDP 04	VRV 03 M6	VRCN 16	VAV 04 M5	VRY 02	AA4
DCKNR/L	3232	P 16	32	32	170	40							

DCBNR ÜRÜN / PRODUCT 75°

TEKNİK ÇİZİM / TECHNICAL DRAWING

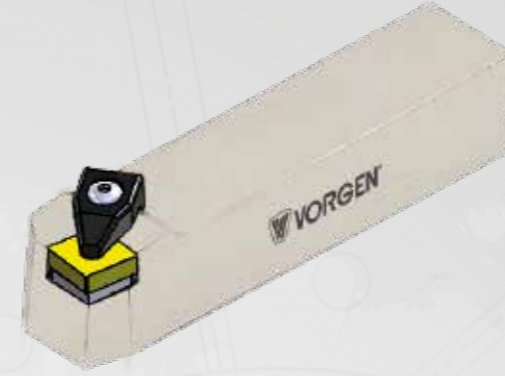

TAKIM KODU ORDERING CODE			KATER ÖLÇÜLERİ DIMENSIONS (mm)				KESİCİ UÇ INSERT	YEDEK PARÇALAR / SPARE PARTS					
								BASKI PARÇASI WEDGE CLAMP	BASKI VİDASI SCREW	ALTLIK SHIM	ALTLIK VİDASI SHIM SCREW	YAY SPRING	ANAHTAR ALLEN KEY
DCBNR/L	2020	K 12	20	20	125	17	CNM.. 12 04..	VDP 02	VRV 02 M6	VRCN 12	VAV 02 M5	VRY 01	AA3
DCBNR/L	2525	M 12	25	25	150	22							
DCBNR/L	3232	P 12	32	32	170	29							
DCBNR/L	2525	M 16	25	25	150	22	CNM.. 16 06..	VDP 04	VRV 03 M6	VRCN 16	VAV 04 M5	VRY 02	AA4
DCBNR/L	3232	P 16	32	32	170	29							

DTGNR ÜRÜN / PRODUCT 90°

TEKNİK ÇİZİM / TECHNICAL DRAWING

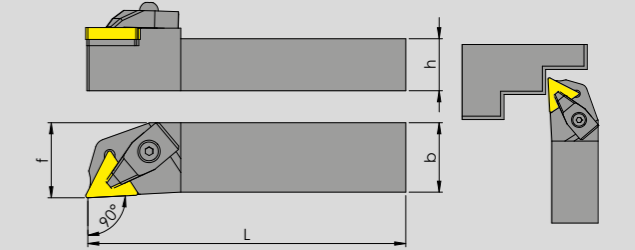

TAKIM KODU ORDERING CODE			KATER ÖLÇÜLERİ DIMENSIONS (mm)				KESİCİ UÇ INSERT	YEDEK PARÇALAR / SPARE PARTS					
								BASKI PARÇASI WEDGE CLAMP	BASKI VİDASI SCREW	ALTLIK SHIM	ALTLIK VİDASI SHIM SCREW	YAY SPRING	ANAHTAR ALLEN KEY
DTGNR/L	2020	K 22	20	20	125	25	TNM.. 22 04..	VDP 02	VRV 02 M6	VRTN 22	VAV 02 M5	VRY 01	AA3
DTGNR/L	2525	M 22	25	25	150	32							
DTGNR/L	3232	P 22	32	32	170	40							
DTGNR/L	4040	S 22	40	40	250	50	TNM.. 16 04..	VDP 02	VRV 02 M6	VRTN 16	VAV 11 M5	VRY 01	AA3
DTGNR/L	2020	K 16	20	20	125	25							
DTGNR/L	2525	M 16	25	25	150	32							
DTGNR/L	3232	P 16	32	32	170	40							

DVQNR ÜRÜN / PRODUCT

117,5°

TEKNİK ÇİZİM / TECHNICAL DRAWING

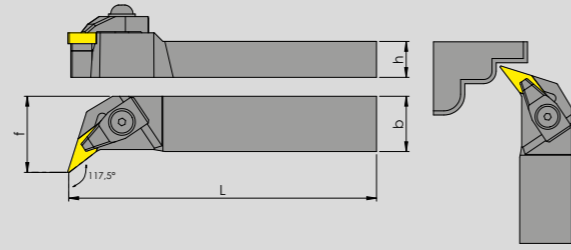

TAKIM KODU ORDERING CODE			KATER ÖLÇÜLERİ DIMENSIONS (mm)				KESİCİ UÇ INSERT	YEDEK PARÇALAR / SPARE PARTS					
			h	b	L	f		BASKI PARÇASI WEDGE CLAMP	BASKI VIDASI SCREW	ALTLIK SHIM	ALTLIK VIDASI SHIM SCREW	YAY SPRING	ANAHTAR ALLEN KEY
DVQNR/L	2020	K 16	20	20	125	25	VNM.. 16 04..	VDP 03	VRV 02 M6	VRVB 12	VAV 10 M5	VRY 01	AA3
DVQNR/L	2525	M 16	25	25	150	32							
DVQNR/L	3232	P 16	32	32	170	40							

DVVNN ÜRÜN / PRODUCT

72,5°

TEKNİK ÇİZİM / TECHNICAL DRAWING

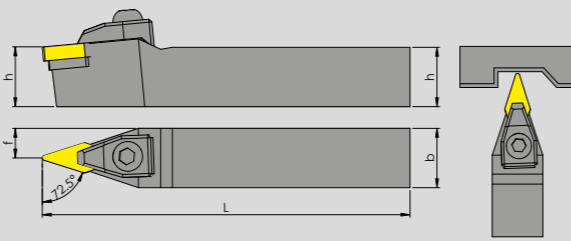

TAKIM KODU ORDERING CODE			KATER ÖLÇÜLERİ DIMENSIONS (mm)				KESİCİ UÇ INSERT	YEDEK PARÇALAR / SPARE PARTS					
			h	b	L	f		BASKI PARÇASI WEDGE CLAMP	BASKI VIDASI SCREW	ALTLIK SHIM	ALTLIK VIDASI SHIM SCREW	YAY SPRING	ANAHTAR ALLEN KEY
DVVNN	2020	K 16	20	20	125	25	VNM.. 16 04..	VDP 03	VRV 02 M6	VRVB 12	VAV 10 M5	VRY 01	AA3
DVVNN	2525	M 16	25	25	150	32							
DVVNN	3232	P 16	32	32	170	40							

DCMNN ÜRÜN / PRODUCT

50°

TEKNİK ÇİZİM / TECHNICAL DRAWING

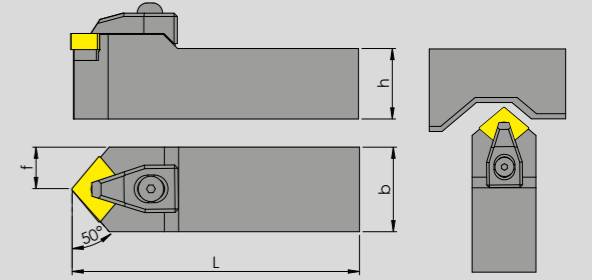

TAKIM KODU ORDERING CODE			KATER ÖLÇÜLERİ DIMENSIONS (mm)				KESİCİ UÇ INSERT	YEDEK PARÇALAR / SPARE PARTS					
			h	b	L	f		BASKI PARÇASI WEDGE CLAMP	BASKI VIDASI SCREW	ALTLIK SHIM	ALTLIK VIDASI SHIM SCREW	YAY SPRING	ANAHTAR ALLEN KEY
DCMNN	2020	K 12	20	20	125	10	CNM.. 12 04..	VDP 02	VRV 02 M6	VRCN 12	VAV 02 M5	VRY 01	AA3
DCMNN	2525	M 12	25	25	150	12,5							
DCMNN	3232	P 12	32	32	170	16							
DCMNN	3232	P 16	32	32	170	16	CNM.. 16 06..	VDP 04	VRV 03 M6	VRCN 16	VAV 04 M5	VRY 02	AA4

DWLNR ÜRÜN / PRODUCT

95°

TEKNİK ÇİZİM / TECHNICAL DRAWING

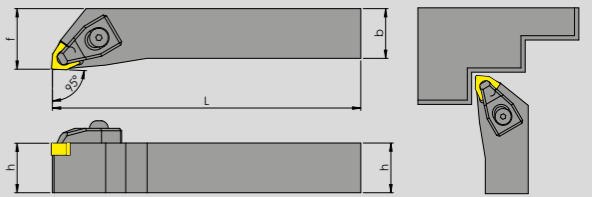

TAKIM KODU ORDERING CODE			KATER ÖLÇÜLERİ DIMENSIONS (mm)				KESİCİ UÇ INSERT	YEDEK PARÇALAR / SPARE PARTS					
			h	b	L	f		BASKI PARÇASI WEDGE CLAMP	BASKI VIDASI SCREW	ALTLIK SHIM	ALTLIK VIDASI SHIM SCREW	YAY SPRING	ANAHTAR ALLEN KEY
DWLNR/L	1616	H 16	16	16	100	20	WNM.. 06 04..	VDP 01	VRV 01 M5			VRY 01	AA3
DWLNR/L	2020	K 06	20	20	125	25							
DWLNR/L	2525	M06	25	25	150	32							
DWLNR/L	2020	K 08	20	20	125	25	WNM.. 08 04..	VDP 02	VRV 02 M6	VRWN 08	VAV 02 M5	VRY 01	AA3
DWLNR/L	2525	M 08	25	25	150	32							
DWLNR/L	3232	P 08	32	32	170	40							

DSKNR ÜRÜN / PRODUCT

75°

TEKNİK ÇİZİM / TECHNICAL DRAWING

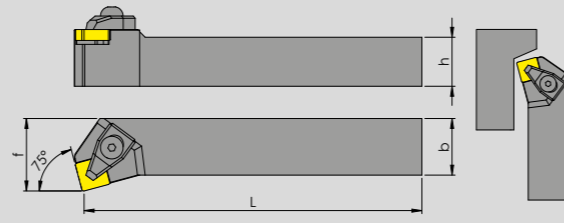

TAKIM KODU ORDERING CODE			KATER ÖLÇÜLERİ DIMENSIONS (mm)				KESİCİ UÇ INSERT	YEDEK PARÇALAR / SPARE PARTS					
								BASKI PARÇASI WEDGE CLAMP	BASKI VİDASI SCREW	ALTLIK SHIM	ALTLIK VİDASI SHIM SCREW	YAY SPRING	ANAHTAR ALLEN KEY
DSKNR/L	2020	K 12	h	b	L	f							
DSKNR/L	2525	M 12	20	20	125	25	SNM.. 12 04..	VDP 02	VRV 02 M6	VRSN 12	VAV 02 M5	VRY 01	AA3
DSKNR/L	3232	P 12	25	25	150	32		VDP 04	VRV 03 M6	VRSN 15	VAV 04 M5	VRY 02	AA4
DSKNR/L	3232	P 15	32	32	170	40		VDP 04	VRV 03 M6	VRSN 15	VAV 04 M5	VRY 02	AA4

DSDNN ÜRÜN / PRODUCT

45°

TEKNİK ÇİZİM / TECHNICAL DRAWING



TAKIM KODU ORDERING CODE			KATER ÖLÇÜLERİ DIMENSIONS (mm)				KESİCİ UÇ INSERT	YEDEK PARÇALAR / SPARE PARTS					
								BASKI PARÇASI WEDGE CLAMP	BASKI VİDASI SCREW	ALTLIK SHIM	ALTLIK VİDASI SHIM SCREW	YAY SPRING	ANAHTAR ALLEN KEY
DSDNN	2020	K 12	h	b	L	f							
DSDNN	2525	M 12	20	20	125	10	SNM.. 12 04..	VDP 02	VRV 02 M6	VRSN 12	VAV 02 M5	VRY 01	AA3
DSDNN	3232	P 12	25	25	150	12,5		VDP 04	VRV 03 M6	VRSN 15	VAV 04 M5	VRY 02	AA4
DSDNN	3232	P 15	32	32	170	16		VDP 04	VRV 03 M6	VRSN 15	VAV 04 M5	VRY 02	AA4

DSSNR ÜRÜN / PRODUCT

45°

TEKNİK ÇİZİM / TECHNICAL DRAWING

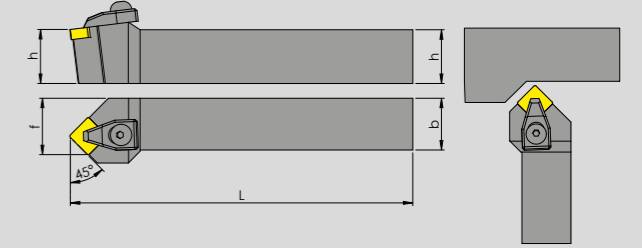

TAKIM KODU ORDERING CODE			KATER ÖLÇÜLERİ DIMENSIONS (mm)				KESİCİ UÇ INSERT	YEDEK PARÇALAR / SPARE PARTS					
								BASKI PARÇASI WEDGE CLAMP	BASKI VİDASI SCREW	ALTLIK SHIM	ALTLIK VİDASI SHIM SCREW	YAY SPRING	ANAHTAR ALLEN KEY
DSSNR/L	2020	K 12	h	b	L	f							
DSSNR/L	2525	M 12	20	20	125	25	SNM.. 12 04..	VDP 02	VRV 02 M6	VRSN 12	VAV 02 M5	VRY 01	AA3
DSSNR/L	3232	P 12	25	25	150	32		VDP 04	VRV 03 M6	VRSN 15	VAV 04 M5	VRY 02	AA4
DSSNR/L	3232	P 15	32	32	170	40		VDP 05	VRV 03 M6	VRSN 19	VAV 05 M6	VRY 02	AA4

DTJNR ÜRÜN / PRODUCT

93°

TEKNİK ÇİZİM / TECHNICAL DRAWING

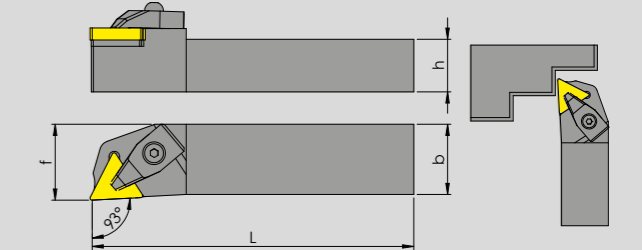

TAKIM KODU ORDERING CODE			KATER ÖLÇÜLERİ DIMENSIONS (mm)				KESİCİ UÇ INSERT	YEDEK PARÇALAR / SPARE PARTS					
								BASKI PARÇASI WEDGE CLAMP	BASKI VİDASI SCREW	ALTLIK SHIM	ALTLIK VİDASI SHIM SCREW	YAY SPRING	ANAHTAR ALLEN KEY
DTJNR/L	2020	K 22	h	b	L	f							
DTJNR/L	2525	M 22	20	20	125	25	TNM.. 22 04..	VDP 02	VRV 02 M6	VRTN 22	VAV 02 M5	VRY 01	AA3
DTJNR/L	3232	P 22	25	25	150	32		VDP 02	VRV 02 M6	VRTN 16	VAV 11 M5	VRY 01	AA3
DTJNR/L	3232	P 16	32	32	170	40		VDP 02	VRV 02 M6	VRTN 16	VAV 11 M5	VRY 01	AA3

DVJNR ÜRÜN / PRODUCT

93°

TEKNİK ÇİZİM / TECHNICAL DRAWING

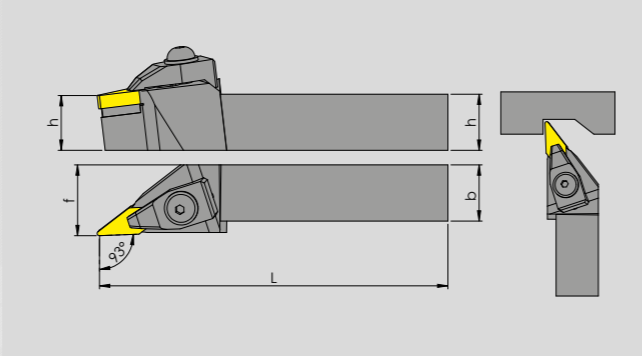

TAKIM KODU ORDERING CODE	KATER ÖLÇÜLERİ DIMENSIONS (mm)				KESİCİ UÇ INSERT	YEDEK PARÇALAR / SPARE PARTS					
	h	b	L	f		BASKI PARÇASI WEDGE CLAMP	BASKI VİDASI SCREW	ALTLIK SHIM	ALTLIK VİDASI SHIM SCREW	YAY SPRING	ANAHTAR ALLEN KEY
DVJNR/L 2020 K 16	20	20	125	25	VNM.. 16 04..	VDP 03	VRV 02 M6	VRVB 12	VAV 10 M5	VRY 01	AA3
DVJNR/L 2525 M 16	25	25	150	32							
DVJNR/L 3232 P 16	32	32	170	40							

DVHNR ÜRÜN / PRODUCT

107,5°

TEKNİK ÇİZİM / TECHNICAL DRAWING

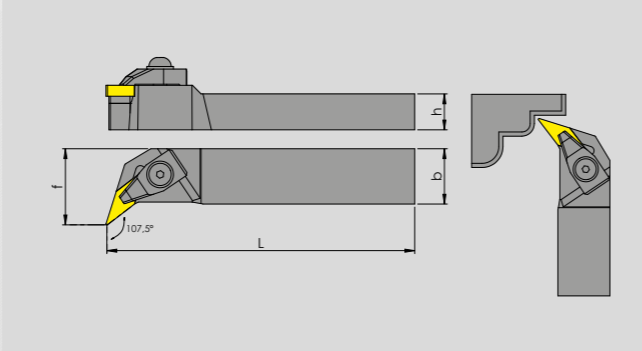

TAKIM KODU ORDERING CODE	KATER ÖLÇÜLERİ DIMENSIONS (mm)				KESİCİ UÇ INSERT	YEDEK PARÇALAR / SPARE PARTS					
	h	b	L	f		BASKI PARÇASI WEDGE CLAMP	BASKI VİDASI SCREW	ALTLIK SHIM	ALTLIK VİDASI SHIM SCREW	YAY SPRING	ANAHTAR ALLEN KEY
DVHNR/L 2020 K 16	20	20	125	25	VNM.. 16 04..	VDP 03	VRV 02 M6	VRVB 12	VAV 10 M5	VRY 01	AA3
DVHNR/L 2525 M 16	25	25	150	32							
DVHNR/L 3232 P 16	32	32	170	40							

M SİSTEM DIŞ
TORNA KATERLERİ

M System external
lathe tool holders
www.vorgen.com



The red power for
the professionals
Profesyoneller için
Kırmızı Güç

MWLNR ÜRÜN / PRODUCT

95°

TEKNİK ÇİZİM / TECHNICAL DRAWING

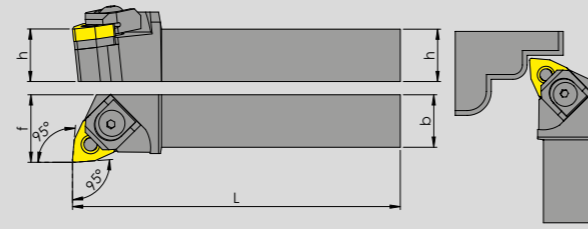

TAKIM KODU ORDERING CODE			KATER ÖLÇÜLERİ DIMENSIONS (mm)				KESİCİ UÇ INSERT	YEDEK PARÇALAR / SPARE PARTS					
			h	b	L	f		BASKI PARÇASI WEDGE CLAMP	BASKI VIDASI SCREW	ALTLIK SHIM	ALTLIK VIDASI SHIM SCREW	YAY SPRING	ANAHTAR ALLEN KEY
MWLNR/L	2020	K 08	20	20	125	25	WNM.. 08 04..	VMP 02	VRV 02 M6	VRWN 08	VAV 10 M6	VRY 01	AA3
MWLNR/L	2525	M 08	25	25	150	32							
MWLNR/L	3232	P 08	32	32	170	40							
MWLNR/L	2020	K 06	20	20	125	25	WNM.. 06 04..	VMP 01	VRV 01 M5	VAV 08 M5	VRY 01	AA3	
MWLNR/L	2525	M 06	25	25	150	32							

MWENN ÜRÜN / PRODUCT

50°

TEKNİK ÇİZİM / TECHNICAL DRAWING

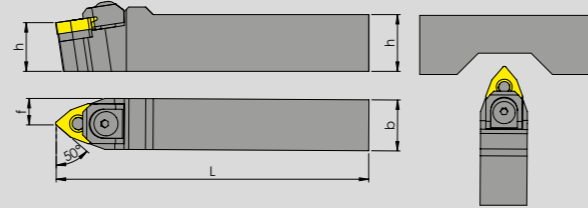

TAKIM KODU ORDERING CODE			KATER ÖLÇÜLERİ DIMENSIONS (mm)				KESİCİ UÇ INSERT	YEDEK PARÇALAR / SPARE PARTS					
			h	b	L	f		BASKI PARÇASI WEDGE CLAMP	BASKI VIDASI SCREW	ALTLIK SHIM	ALTLIK VIDASI SHIM SCREW	YAY SPRING	ANAHTAR ALLEN KEY
MWENN	2020	K 08	20	20	125	10	WNM.. 08 04..	VMP 02	VRV 02 M6	VRWN 08	VAV 10 M6	VRY 01	AA3
MWENN	2525	M 08	25	25	150	12,5							
MWENN	3232	P 08	32	32	170	16							
MWENN	2020	K 06	20	20	125	10	WNM.. 06 04..	VMP 01	VRV 01 M5	VAV 08 M5	VRY 01	AA3	
MWENN	2525	M 06	25	25	150	12,5							

MTENN ÜRÜN / PRODUCT

60°

TEKNİK ÇİZİM / TECHNICAL DRAWING

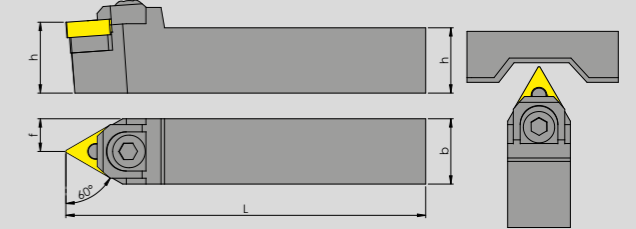

TAKIM KODU ORDERING CODE			KATER ÖLÇÜLERİ DIMENSIONS (mm)				KESİCİ UÇ INSERT	YEDEK PARÇALAR / SPARE PARTS					
			h	b	L	f		BASKI PARÇASI WEDGE CLAMP	BASKI VIDASI SCREW	ALTLIK SHIM	ALTLIK VIDASI SHIM SCREW	YAY SPRING	ANAHTAR ALLEN KEY
MTENN	2020	K 16	20	20	125	10	TNM.. 16 04..	VMP 03	VRV 01 M5	VRTN 16	VAV 08 M5	VRY 01	AA3
MTENN	2525	M 16	25	25	150	12,5							
MTENN	3232	P 16	32	32	170	16							
MTENN	2020	K 22	20	20	125	25	TNM.. 22 04..	VMP 04	VRV 02 M6	VRTN 22	VAV 02 M5	VRY 01	AA3
MTENN	2525	M 22	25	25	150	12,5							
MTENN	3232	P 22	32	32	170	16							

MTJNR ÜRÜN / PRODUCT

93°

TEKNİK ÇİZİM / TECHNICAL DRAWING

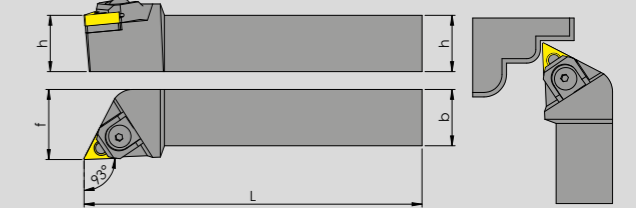

TAKIM KODU ORDERING CODE			KATER ÖLÇÜLERİ DIMENSIONS (mm)				KESİCİ UÇ INSERT	YEDEK PARÇALAR / SPARE PARTS					
			h	b	L	f		BASKI PARÇASI WEDGE CLAMP	BASKI VIDASI SCREW	ALTLIK SHIM	ALTLIK VIDASI SHIM SCREW	YAY SPRING	ANAHTAR ALLEN KEY
MTJNR/L	2020	K 16	20	20	125	25	TNM.. 16 04..	VMP 03	VRV 01 M5	VRTN 16	VAV 08 M5	VRY 01	AA3
MTJNR/L	2525	M 16	25	25	150	32							
MTJNR/L	3232	P 16	32	32	170	40							
MTJNR/L	2020	K 22	20	20	125	25	TNM.. 22 04..	VMP 04	VRV 02 M6	VRTN 22	VAV 02 M5	VRY 01	AA3
MTJNR/L	2525	M 22	25	25	150	32							
MTJNR/L	3232	P 22	32	32	170	40							

C SİSTEM DIŞ
TORNA KATERLERİ
C System external
lathe tool holders
www.vorgen.com



The red power for
the professionals
Profesyoneller için
Kırmızı Güç

CKJNR ÜRÜN / PRODUCT 93°  **TEKNİK ÇİZİM / TECHNICAL DRAWING**



TAKIM KODU ORDERING CODE	KATER ÖLÇÜLERİ DIMENSIONS (mm)						KESİCİ UÇ INSERT	YEDEK PARÇALAR / SPARE PARTS					
	h	b	L	f	BASKI PARÇASI WEDGE CLAMP	BASKI VIDASI SCREW		ALTLIK SHIM	ALTLIK VIDASI SHIM SCREW	YAY SPRING	ANAHTAR ALLEN KEY		
CKJNR/L 2020	20	20	125	25									
CKJNR/L 2525	25	25	150	32	KNUX16 R/L	VCP 01	VRV 04 M6	VRKN 16 R/L	VAV 01 M3	VRV 02	AA4		
CKJNR/L 3232	32	32	170	40									
CKJNR/L 4040	40	40	250	50									

CTGPR ÜRÜN / PRODUCT 90°  **TEKNİK ÇİZİM / TECHNICAL DRAWING**

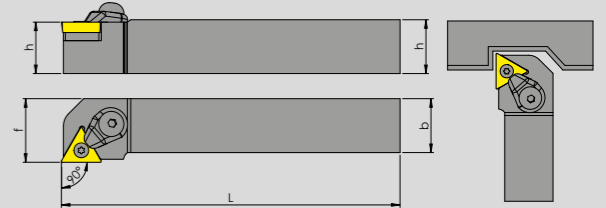

TAKIM KODU ORDERING CODE	KATER ÖLÇÜLERİ DIMENSIONS (mm)						KESİCİ UÇ INSERT	YEDEK PARÇALAR / SPARE PARTS				
	h	b	L	f	BASKI PARÇASI WEDGE CLAMP	BASKI VIDASI SCREW		ALTLIK SHIM	ALTLIK VIDASI SHIM SCREW	ANAHTAR TORX KEY		
CTGPR/L 2020	20	20	125	25								
CTGPR/L 2525	25	25	150	32	TP 1603..	VCP 03	VRV 04 M6	VRTB 16	VAV 02 M5	T15		
CTGPR/L 2525	25	25	150	32								
CTGPR/L 3232	32	32	170	40								

CSDNN ÜRÜN / PRODUCT 45°

TEKNİK ÇİZİM / TECHNICAL DRAWING



TAKIM KODU ORDERING CODE			KATER ÖLÇÜLERİ DIMENSIONS (mm)				KESİCİ UÇ INSERT	YEDEK PARÇALAR / SPARE PARTS					
			h	b	L	f		BASKI PARÇASI WEDGE CLAMP	BASKI VIDASI SCREW	ALTLIK SHIM	ALTLIK VIDASI SHIM SCREW	YAY SPRING	ANAHTAR ALLEN KEY
CSDNN	2525	M 12	25	25	150	12,5	SNM.. 12 04..	VCP 07	VRV 07 M6	VRSN 12	VAV 02 M5		AA4
CSDNN	3232	P 12	32	32	170	16							

CSSNR ÜRÜN / PRODUCT 45°

TEKNİK ÇİZİM / TECHNICAL DRAWING



TAKIM KODU ORDERING CODE			KATER ÖLÇÜLERİ DIMENSIONS (mm)				KESİCİ UÇ INSERT	YEDEK PARÇALAR / SPARE PARTS					
			h	b	L	f		BASKI PARÇASI WEDGE CLAMP	BASKI VIDASI SCREW	ALTLIK SHIM	ALTLIK VIDASI SHIM SCREW	YAY SPRING	ANAHTAR ALLEN KEY
CSSNR	2525	M 12	25	25	150	12,5	SNM.. 12 04..	VCP 07	VRV 07 M6	VRSN 12	VAV 02 M5		AA4
CSSNR	3232	P 12	32	32	170	16							

CDJNR ÜRÜN / PRODUCT 93°

TEKNİK ÇİZİM / TECHNICAL DRAWING

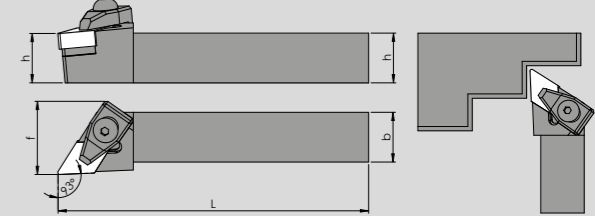
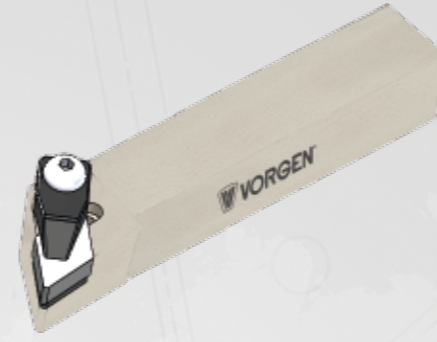

TAKIM KODU ORDERING CODE			KATER ÖLÇÜLERİ DIMENSIONS (mm)				KESİCİ UÇ INSERT	YEDEK PARÇALAR / SPARE PARTS					
			h	b	L	f		BASKI PARÇASI WEDGE CLAMP	BASKI VIDASI SCREW	ALTLIK SHIM	ALTLIK VIDASI SHIM SCREW	YAY SPRING	ANAHTAR ALLEN KEY
CDJNR/L	2525	M15	25	25	150	32	DNM.. 15 16..	VCP 07	VRV 07 M6	VRDN 15	VAV 02 M5		AA4
CDJNR/L	3232	P15	32	32	170	40							



The red power for
the professionals
Profesyoneller için
KIRMIZI GÜÇ

VORGEN®

S SİSTEM DIŞ
TORNA KATERLERİ
S System external
lathe tool holders

www.vorgen.com

VORGEN®
VOF
SDNC

VORGEN®
SRDCN 2525 M10

VORGEN®
SVJBR 2020 K10

SRHCR ÜRÜN / PRODUCT

TEKNİK ÇİZİM / TECHNICAL DRAWING

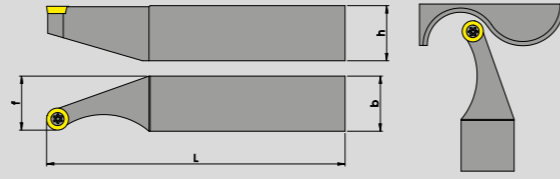

TAKIM KODU ORDERING CODE			KATER ÖLÇÜLERİ DIMENSIONS (mm)				KESİCİ UÇ INSERT	YEDEK PARÇALAR / SPARE PARTS			
			h	b	L	f		BASKI PARÇASI WEDGE CLAMP	BASKI VIDASI SCREW	ALTLIK VIDASI SHIM SCREW	ANAHTAR TORX KEY
SRHCR/L	2525	K 10	25	25	125	25			VRT 06 M3,5x11		
SRHCR/L	2525	K 12	25	25	125	25	RC.. 12		VRT 06 M3,5x9		T15

STJCR ÜRÜN / PRODUCT

93°

TEKNİK ÇİZİM / TECHNICAL DRAWING

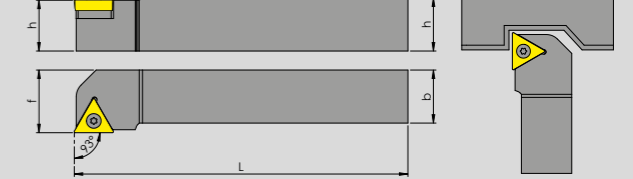

TAKIM KODU ORDERING CODE			KATER ÖLÇÜLERİ DIMENSIONS (mm)				KESİCİ UÇ INSERT	YEDEK PARÇALAR / SPARE PARTS			
			h	b	L	f		BASKI VIDASI SCREW	ALTLIK SHIM	ALTLIK VIDASI SHIM SCREW	ANAHTAR TORX KEY
STJCR/L	1616	H 16	16	16	100	20					
STJCR/L	2020	K 16	20	20	125	25	TC.. 16 T3..	VRT 07 M3,5x11	VRTC 16	VAV 06 M5.05	T15
STJCR/L	2525	M 16	25	25	150	32					
STJCR/L	3232	P 16	32	32	170	40					

STTCN ÜRÜN / PRODUCT

90°

TEKNİK ÇİZİM / TECHNICAL DRAWING

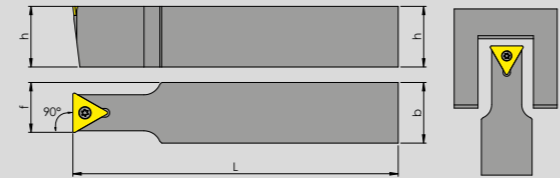

TAKIM KODU ORDERING CODE			KATER ÖLÇÜLERİ DIMENSIONS (mm)				KESİCİ UÇ INSERT	YEDEK PARÇALAR / SPARE PARTS			
			h	b	L	f		SIKMA VIDASI SCREW	ALTLIK SHIM	ALTLIK VIDASI SHIM SCREW	ANAHTAR TORX KEY
STTCN	2525	P 11	25	25	170	12,5					
STTCN	2525	P 16	25	25	170	12,5	TC.. 16 T3..	VRT 07 M3,5x11			T15
STTCN	3232	P 16	32	32	170	16					
STTCN	3232	P 22	32	32	170	16	TC.. 22 04..	VRT 11 M4,5x16			T20

SCACR ÜRÜN / PRODUCT

90°

TEKNİK ÇİZİM / TECHNICAL DRAWING

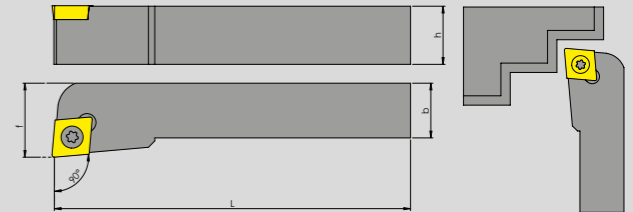

TAKIM KODU ORDERING CODE			KATER ÖLÇÜLERİ DIMENSIONS (mm)				KESİCİ UÇ INSERT	YEDEK PARÇALAR / SPARE PARTS			
			h	b	L	f		BASKI VIDASI SCREW	ALTLIK SHIM	ALTLIK VIDASI SHIM SCREW	ANAHTAR TORX KEY
SCARC/L	1212	F 09	12	12	80	16					
SCARC/L	1616	H 09	16	16	100	20	CCM.. 09 04..	VRT 07 M3,5x11	VRCM 09	VAV 06 M5.05	T15
SCARC/L	2020	K 09	20	20	125	25					
SCARC/L	2525	M 09	25	25	150	32					
SCARC/L	2525	K 12	20	20	125	25	CCM.. 12 04..	VRT 07 M3,5x11	VRCM 12		T20
SCARC/L	2525	M 12	25	25	150	32					

SSDCN ÜRÜN / PRODUCT

45°

TEKNİK ÇİZİM / TECHNICAL DRAWING



TAKIM KODU ORDERING CODE			KATER ÖLÇÜLERİ DIMENSIONS (mm)				KESİCİ UÇ INSERT	YEDEK PARÇALAR / SPARE PARTS			
			h	b	L	f		BASKI VIDASI SCREW	ALTLIK SHIM	ALTLIK VIDASI SHIM SCREW	ANAHTAR TORX KEY
SSDCN	2020	K 12	20	20	125	10	SC.T.. 12 04..	VRT 10 M4,5x12	VRSC 12	VAV 06 M5.05	T15
SSDCN	2525	M 12	25	25	150	12,5					

SDHCR ÜRÜN / PRODUCT

107,5°

TEKNİK ÇİZİM / TECHNICAL DRAWING

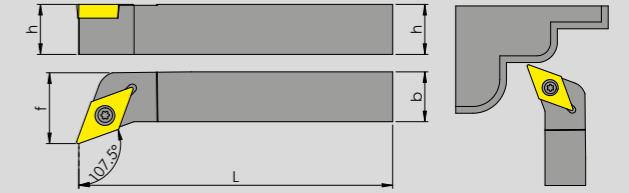

TAKIM KODU ORDERING CODE			KATER ÖLÇÜLERİ DIMENSIONS (mm)				KESİCİ UÇ INSERT	YEDEK PARÇALAR / SPARE PARTS			
			h	b	L	f		BASKI VIDASI SCREW	ALTLIK SHIM	ALTLIK VIDASI SHIM SCREW	ANAHTAR TORX KEY
SDHCR/L	2020	K 11	20	20	125	25	DCM.. 11 T3..	VRT 07 M3,5x11	VRDC 11	VAV 06 M5.05	T15
SDHCR/L	2525	M 11	25	25	150	32					

SDJCR ÜRÜN / PRODUCT

93°

TEKNİK ÇİZİM / TECHNICAL DRAWING



TAKIM KODU ORDERING CODE			KATER ÖLÇÜLERİ DIMENSIONS (mm)				KESİCİ UÇ INSERT	YEDEK PARÇALAR / SPARE PARTS			
			h	b	L	f		BASKI VIDASI SCREW	ALTLIK SHIM	ALTLIK VIDASI SHIM SCREW	ANAHTAR TORX KEY
SDJCR/L	1212	F 07	12	12	80	16	DCM.. 07 T3..	VRT 03 M2,5x5			T08
SDJCR/L	1212	F 11	12	12	80	16					
SDJCR/L	1616	H 11	16	16	100	20	DCM.. 11 T3..	VRT 07 M3,5x11	VRDC 11	VAV 06 M5.05	T15
SDJCR/L	2020	K 11	20	20	125	25					
SDJCR/L	2525	M 11	25	25	150	32					
SDJCR/L	3232	P 11	32	32	170	40					
SDJCR/L	2525	M 11 altlıksız	25	25	150	32	DCM.. 11 T3..	VRT 07 M3,5x11			T15

STGCR ÜRÜN / PRODUCT

90°

TEKNİK ÇİZİM / TECHNICAL DRAWING

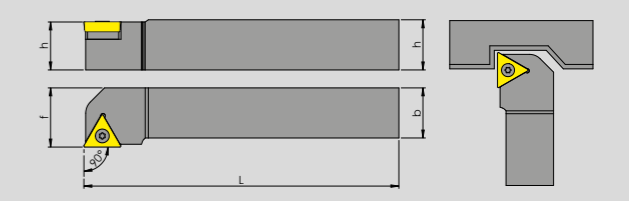

TAKIM KODU ORDERING CODE			KATER ÖLÇÜLERİ DIMENSIONS (mm)				KESİCİ UÇ INSERT	YEDEK PARÇALAR / SPARE PARTS			
			h	b	L	f		BASKI VIDASI SCREW	ALTLIK SHIM	ALTLIK VIDASI SHIM SCREW	ANAHTAR TORX KEY
STGCR/L	1616	H 16	16	16	100	20	TC.. 16 T3..	VRT 07 M3,5x11	VRTC 16	VAV 06 M5.05	T15
STGCR/L	2020	K 16	20	20	125	25					
STGCR/L	2525	M 16	25	25	150	32					
STGCR/L	3232	P 16	32	32	170	40					

SDNCN ÜRÜN / PRODUCT 62,5°

TEKNİK ÇİZİM / TECHNICAL DRAWING

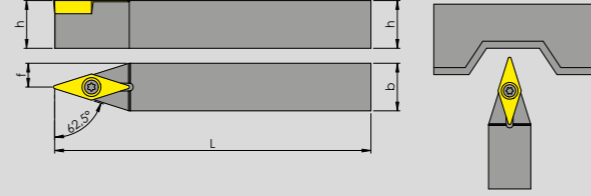

TAKIM KODU ORDERING CODE			KATER ÖLÇÜLERİ DIMENSIONS (mm)				KESİCİ UÇ INSERT	YEDEK PARÇALAR / SPARE PARTS			
								BASKI VIDASI SCREW	ALTLIK SHIM	ALTLIK VIDASI SHIM SCREW	ANAHTAR TORX KEY
SDNCN	1212	F 07	12	12	80	6	DCM.. 07 T3..	VRT 03 M2,5x5			T08
SDNCN	1212	F 11	12	12	80	6	DCM.. 11 T3..	VRT 06 M3,5x9			T15
SDNCN	1616	H 11	16	16	100	8	DCM.. 11 T3..	VRT 07 M3,5x11	VRDC 11	VAV 06 M5.05	T15
SDNCN	2020	K 11	20	20	125	10					
SDNCN	2525	M 11	25	25	150	12,5					
SDNCN	3232	P 11	32	32	170	16	DCM.. 11 T3..	VRT 07 M3,5x11			T15
SDNCN	2525	M 11 atlıksız	25	25	150	12,5					

SVJBR ÜRÜN / PRODUCT 93°

TEKNİK ÇİZİM / TECHNICAL DRAWING

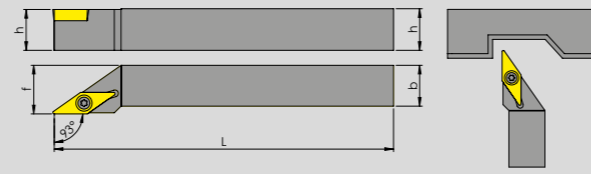

TAKIM KODU ORDERING CODE			KATER ÖLÇÜLERİ DIMENSIONS (mm)				KESİCİ UÇ INSERT	YEDEK PARÇALAR / SPARE PARTS			
								BASKI VIDASI SCREW	ALTLIK SHIM	ALTLIK VIDASI SHIM SCREW	ANAHTAR TORX KEY
SVJBR/L	1212	F 11	12	12	80	16	VBM.. 11 03..	VRT 03 M2,5x5			T08
SVJBR/L	1616	H 11	16	16	100	20	VBM.. 11 03..	VRT 03 M2,5x5			T08
SVJBR/L	2020	K 11	20	20	125	25					
SVJBR/L	2020	K 16	20	20	125	25	VBM.. 16 04..	VRT 07 M3,5x11	VRVB 16	VAV 06 M5.05	T15
SVJBR/L	2525	M 16	25	25	150	32					
SVJBR/L	3232	P 16	32	32	170	40					
SVJBR/L	2525	M 16 atlıksız	25	25	150	32	VBM.. 16 04..	VRT 07 M3,5x11			T15

SVVBN ÜRÜN / PRODUCT 72,5°

TEKNİK ÇİZİM / TECHNICAL DRAWING

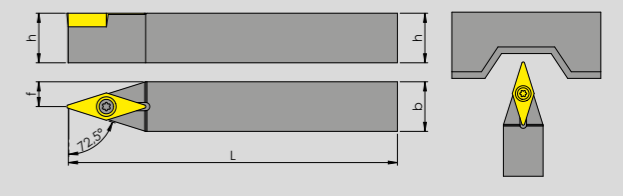

TAKIM KODU ORDERING CODE			KATER ÖLÇÜLERİ DIMENSIONS (mm)				KESİCİ UÇ INSERT	YEDEK PARÇALAR / SPARE PARTS			
								BASKI VIDASI SCREW	ALTLIK SHIM	ALTLIK VIDASI SHIM SCREW	ANAHTAR TORX KEY
SVVBN	1212	F 11	12	12	80	6	VBM.. 11 03..	VRT 03 M2,5x5			T08
SVVBN	1616	H 11	16	16	100	8	VBM.. 11 03..	VRT 03 M2,5x5	VRDC 11	VAV 06 M5.05	T08
SVVBN	2020	K 11	20	20	125	10					
SVVBN	2020	K 16	20	20	125	10	VBM.. 16 04..	VRT 07 M3,5x11	VRVB 16	VAV 06 M5.05	T15
SVVBN	2525	M 16	25	25	150	12,5					
SVVBN	3232	P 16	32	32	170	16					
SVVBN	2525	M 16 atlıksız	25	25	150	12,5	VBM.. 16 04..	VRT 07 M3,5x11			T15

SVHBR ÜRÜN / PRODUCT 107,5°

TEKNİK ÇİZİM / TECHNICAL DRAWING

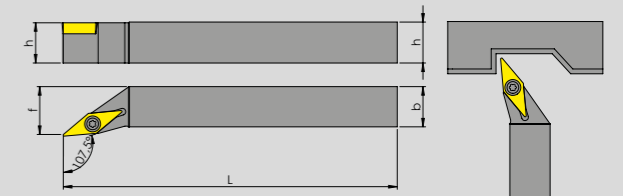

TAKIM KODU ORDERING CODE			KATER ÖLÇÜLERİ DIMENSIONS (mm)				KESİCİ UÇ INSERT	YEDEK PARÇALAR / SPARE PARTS			
								BASKI VIDASI SCREW	ALTLIK SHIM	ALTLIK VIDASI SHIM SCREW	ANAHTAR TORX KEY
SVHBR/L	1212	F 11	12	12	80	16	VBM.. 11 03..	VRT 03 M2,5x5			T08
SVHBR/L	1616	H 11	16	16	100	20	VBM.. 11 03..	VRT 03 M2,5x5	VRDC 11	VAV 06 M5.05	T08
SVHBR/L	2020	K 11	20	20	125	25					
SVHBR/L	2020	K 16	20	20	125	25	VBM.. 16 04..	VRT 07 M3,5x11	VRVB 16	VAV 06 M5.05	T15
SVHBR/L	2525	M 16	25	25	150	32					
SVHBR/L	3232	P 16	32	25	170	40					
SVHBR/L	2525	M 16 atlıksız	25	25	150	32	VBM.. 16 04..	VRT 07 M3,5x11			T15

SVHCR ÜRÜN / PRODUCT

107,5°

TEKNİK ÇİZİM / TECHNICAL DRAWING

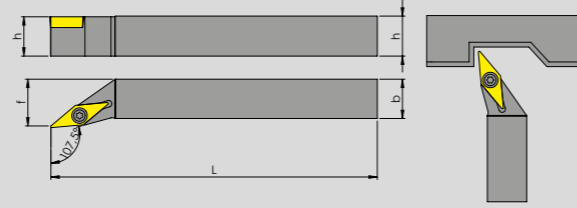

TAKIM KODU ORDERING CODE	KATER ÖLÇÜLERİ DIMENSIONS (mm)				KESİCİ UÇ INSERT	YEDEK PARÇALAR / SPARE PARTS			
	h	b	L	f		BASKI VIDASI SCREW	ALTLIK SHIM	ALTLIK VIDASI SHIM SCREW	ANAHTAR TORX KEY
SVHCR/L 1212 F 11	12	12	80	16	VCM.. 11 03..	VRT 03 M2,5x5			T08
SVHCR/L 1616 H 11	16	16	100	20	VCM.. 11 03..	VRT 03 M2,5x5	VRDC 11	VAV 06 M5.05	T08
SVHCR/L 2020 K 11	20	20	125	25	VCM.. 11 03..	VRT 03 M2,5x5	VRDC 11	VAV 06 M5.05	T08
SVHCR/L 2020 K 16	20	20	125	25	VCM.. 16 04..	VRT 07 M3,5x11	VRVB 16	VAV 06 M5.05	T15
SVHCR/L 2525 M 16	25	25	150	32	VCM.. 16 04..	VRT 07 M3,5x11	VRVB 16	VAV 06 M5.05	T15
SVHCR/L 3232 P 16	32	25	170	40	VCM.. 16 04..	VRT 07 M3,5x11	VRVB 16	VAV 06 M5.05	T15

SVJCR ÜRÜN / PRODUCT

93°

TEKNİK ÇİZİM / TECHNICAL DRAWING

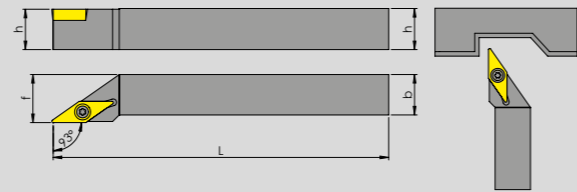

TAKIM KODU ORDERING CODE	KATER ÖLÇÜLERİ DIMENSIONS (mm)				KESİCİ UÇ INSERT	YEDEK PARÇALAR / SPARE PARTS			
	h	b	L	f		BASKI VIDASI SCREW	ALTLIK SHIM	ALTLIK VIDASI SHIM SCREW	ANAHTAR TORX KEY
SVJCR/L 1212 F 11	12	12	80	16	VC.T 11 03..	VRT 03 M2,5x5			T08
SVJCR/L 1616 H 11	16	16	100	20	VC.T 11 03..	VRT 03 M2,5x5	VRDC 11	VAV 06 M5.05	T08
SVJCR/L 2020 K 11	20	20	125	25	VC.T 11 03..	VRT 03 M2,5x5	VRDC 11	VAV 06 M5.05	T08
SVJCR/L 2020 K 16	20	20	125	25	VC.T 16 04..	VRT 07 M3,5x11	VRVB 16	VAV 06 M5.05	T15
SVJCR/L 2525 M 16	25	25	150	32	VC.T 16 04..	VRT 07 M3,5x11	VRVB 16	VAV 06 M5.05	T15
SVJCR/L 3232 P 16	32	32	170	40	VC.T 16 04..	VRT 07 M3,5x11	VRVB 16	VAV 06 M5.05	T15

SVVCN ÜRÜN / PRODUCT

72,5°

TEKNİK ÇİZİM / TECHNICAL DRAWING

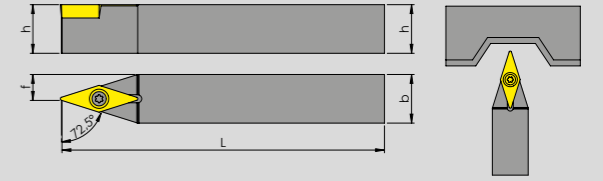

TAKIM KODU ORDERING CODE	KATER ÖLÇÜLERİ DIMENSIONS (mm)				KESİCİ UÇ INSERT	YEDEK PARÇALAR / SPARE PARTS			
	h	b	L	f		BASKI VIDASI SCREW	ALTLIK SHIM	ALTLIK VIDASI SHIM SCREW	ANAHTAR TORX KEY
SVHCR/L 1212 F 11	12	12	80	6	VC.T 11 03..	VRT 03 M2,5x5			T08
SVHCR/L 1616 H 11	16	16	100	8	VC.T 11 03..	VRT 03 M2,5x5			T08
SVHCR/L 2020 K 11	20	20	125	10	VC.T 11 03..	VRT 03 M2,5x5			T08
SVHCR/L 2020 K 16	20	20	125	10	VC.T 16 04..	VRT 07 M3,5x11	VRVB 16	VAV 06 M5.05	T15
SVHCR/L 2525 M 16	25	25	150	12,5	VC.T 16 04..	VRT 07 M3,5x11	VRVB 16	VAV 06 M5.05	T15
SVHCR/L 3232 P 16	32	25	170	16	VC.T 16 04..	VRT 07 M3,5x11	VRVB 16	VAV 06 M5.05	T15

SCLCR ÜRÜN / PRODUCT

95°

TEKNİK ÇİZİM / TECHNICAL DRAWING



TAKIM KODU ORDERING CODE	KATER ÖLÇÜLERİ DIMENSIONS (mm)				KESİCİ UÇ INSERT	YEDEK PARÇALAR / SPARE PARTS			
	h	b	L	f		BASKI VIDASI SCREW	ALTLIK SHIM	ALTLIK VIDASI SHIM SCREW	ANAHTAR TORX KEY
SCLCR/L 1212 F 09	12	12	80	16	CCM.. 09 04..	VRT 03 M2,5x5			T08
SCLCR/L 1616 H 09	16	16	100	20	CCM.. 09 04..	VRT 03 M2,5x5			T08
SVHCR/L 2020 K 09	20	20	125	25	CCM.. 09 04..	VRT 07 M3,5x11	VRCM 09	VAV 06 M5.05	T15
SCLCR/L 2525 M 09	25	25	150	32	CCM.. 09 04..	VRT 07 M3,5x11	VRCM 09	VAV 06 M5.05	T15
SCLCR/L 2525 K 12	20	20	125	25	CCM.. 12 04..	VRT 07 M3,5x11	VRCM 12		T20
SCLCR/L 2525 M 12	25	25	150	32	CCM.. 12 04..	VRT 07 M3,5x11	VRCM 12		T20

SRDCN ÜRÜN / PRODUCT

TEKNİK ÇİZİM / TECHNICAL DRAWING



TAKIM KODU ORDERING CODE	KATER ÖLÇÜLERİ DIMENSIONS (mm)				KESİCİ UÇ INSERT	YEDEK PARÇALAR / SPARE PARTS			
	h	b	L	f		BASKI PARÇASI WEDGE CLAMP	BASKI VIDASI SCREW	ALTLIK VIDASI SHIM SCREW	ANAHTAR TORX KEY
SRDCN 2020 K 06	20	20	125	10	RC.. 06	VCP 03	VRT 09 M4x11	VRT 03 M2,5x5	T08
SRDCN 2525 M 06	25	25	150	12,5					
SRDCN 2020 K 08	20	20	125	10	RC.. 08	VCP 03	VRT 09 M4x11	VRT 05 M3x8	T15
SRDCN 2525 M 08	25	25	150	12,5					
SRDCN 2020 K 10	20	20	125	10	RC.. 10	VCP 03	VRT 09 M4x11	VRT 06 M3,5x9	T15
SRDCN 2525 M 10	25	25	150	12,5					
SRDCN 2020 K 12	20	20	125	10	RC.. 12	VCP 03	VRT 09 M4x11	VRT 06 M3,5x9	T15
SRDCN 2525 M 12	25	25	150	12,5					
SRDCN 2525 M 16	25	25	150	12,5	RC.. 16	VCP 04	VRT 12 M4x16	VRT 11 M4,5x16	T20
SRDCN 3232 P 16	32	32	170	16					
SRDCN 2525 M 20	25	25	150	12,5	RC.. 20	VCP 04	VRT 12 M4x16	VRT 12 M6x16	T20
SRDCN 3232 P 20	32	32	170	16					

SSSCR ÜRÜN / PRODUCT

45°

TEKNİK ÇİZİM / TECHNICAL DRAWING

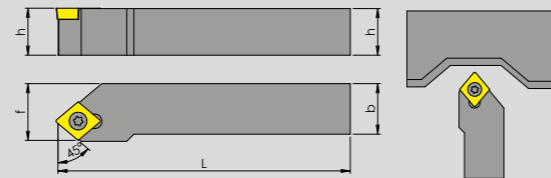

TAKIM KODU ORDERING CODE	KATER ÖLÇÜLERİ DIMENSIONS (mm)				KESİCİ UÇ INSERT	YEDEK PARÇALAR / SPARE PARTS			
	h	b	L	f		BASKI VIDASI SCREW	ALTLIK SHIM	ALTLIK VIDASI SHIM SCREW	ANAHTAR TORX KEY
SSSCR/L 2020 K 12	20	20	125	25	SC.T.. 12 04..	VRT 10 M4,5x12	VRSC 12	VAV 06 M5.05	T15
SSSCR/L 2525 M 12	25	25	150	32					

SCMCN ÜRÜN / PRODUCT

50°

TEKNİK ÇİZİM / TECHNICAL DRAWING

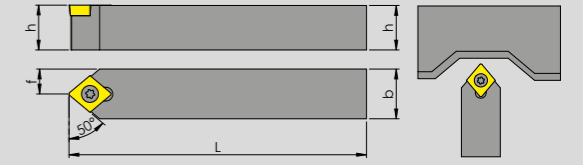

TAKIM KODU ORDERING CODE	KATER ÖLÇÜLERİ DIMENSIONS (mm)				KESİCİ UÇ INSERT	YEDEK PARÇALAR / SPARE PARTS			
	h	b	L	f		BASKI VIDASI SCREW	ALTLIK SHIM	ALTLIK VIDASI SHIM SCREW	ANAHTAR TORX KEY
SCMCN 1212 F 09	12	12	80	06	CCM.. 09 04..	VRT 03 M3,5x9			T15
SCMCN 1616 H 09	16	16	100	08					
SCMCN 2020 K 09	20	20	125	10	CCM.. 09 04..	VRT 07 M3,5x11	VRCM 09	VAV 06 M5.05	T15
SCMCN 2525 M 09	25	25	150	12,5					
SCMCN 2020 K 12	20	20	125	10	CCM.. 12 04..	VRT 10 M4,5x12	VRCM 12		T20
SCMCN 2525 M 12	25	25	150	12,5					

SRGCR ÜRÜN / PRODUCT

TEKNİK ÇİZİM / TECHNICAL DRAWING

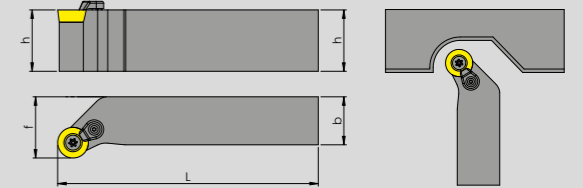

TAKIM KODU ORDERING CODE	KATER ÖLÇÜLERİ DIMENSIONS (mm)				KESİCİ UÇ INSERT	YEDEK PARÇALAR / SPARE PARTS			
	h	b	L	f		BASKI PARÇASI WEDGE CLAMP	BASKI VIDASI SCREW	ALTLIK VIDASI SHIM SCREW	ANAHTAR TORX KEY
SRGCR/L 2020 K 06	20	20	125	25	RC.. 06	VCP 03	VRT 09 M4x11	VRT 06 M3,5x9	T15
SRGCR/L 2525 M 06	25	25	150	32					
SRGCR/L 2020 K 08	20	20	125	25	RC.. 08	VCP 03	VRT 09 M4x11	VRT 06 M3,5x9	T15
SRGCR/L 2525 M 08	25	25	150	32					
SRGCR/L 2020 K 10	20	20	125	25	RC.. 10	VCP 03	VRT 09 M4x11	VRT 06 M3,5x9	T15
SRGCR/L 2525 M 10	25	25	150	32					
SRGCR/L 2020 K 12	20	20	125	25	RC.. 12	VCP 03	VRT 09 M4x11	VRT 06 M3,5x9	T15
SRGCR/L 2525 M 12	25	25	150	32					

P SİSTEM DIŞ TORNA KATERLERİ

P System external
lathe tool holders
www.vorgen.com



TIRTIR DIŞ TORNA KATERLERİ

Inchinemuon clamp
outside diameter



The red power for
the professionals
Profesyoneller için
Kırmızı Güç

PTJNR ÜRÜN / PRODUCT

93°



TEKNİK ÇİZİM / TECHNICAL DRAWING



TAKIM KODU ORDERING CODE	KATER ÖLÇÜLERİ DIMENSIONS (mm)						KESİCİ UÇ INSERT	YEDEK PARÇALAR / SPARE PARTS							
	h	b	L	f	BASKI PARÇASI WEDGE CLAMP	BASKI VIDASI SCREW		ALTLIK SHIM	ALTLIK VIDASI SHIM SCREW	YAY SPRING	ANAHTAR ALLEN KEY				
PTJNR/L 2020	20	20	125	25											
PTJNR/L 2525	25	25	150	32			TNM.. 22 04..	VPDP 03	VPV 03	VPTN 22	VAPV 03				AA3
PTJNR/L 3232	32	32	170	40											
PTJNR/L 4040	40	40	200	50											
PTJNR/L 2020	20	20	125	25			TNM.. 16 04..	VPDP 04	VPV 04	VPTN 16	VAPV 04				AA3
PTJNR/L 2525	25	25	150	32											
PTJNR/L 3232	32	32	170	40											

PCLNR ÜRÜN / PRODUCT

95°



TEKNİK ÇİZİM / TECHNICAL DRAWING

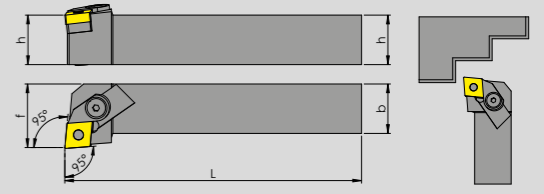

TAKIM KODU ORDERING CODE	KATER ÖLÇÜLERİ DIMENSIONS (mm)						KESİCİ UÇ INSERT	YEDEK PARÇALAR / SPARE PARTS							
	h	b	L	f	BASKI PARÇASI WEDGE CLAMP	BASKI VIDASI SCREW		ALTLIK SHIM	ALTLIK VIDASI SHIM SCREW	YAY SPRING	ANAHTAR ALLEN KEY				
PCLNR/L 2020	20	20	125	25											
PCLNR/L 2525	25	25	150	32			CNM.. 12 04..	VPDP 02	VPV 02	VPCN 12	VAPV 02				AA3
PCLNR/L 3232	32	32	170	40											
PCLNR/L 4040	40	40	200	50											

TIRTIR ÜRÜN / PRODUCT



TIRTIR ÜRÜN / PRODUCT



TEKNİK ÇİZİM / TECHNICAL DRAWING

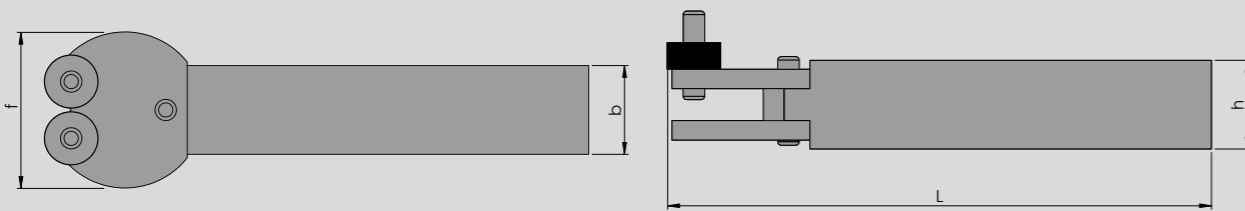

TAKIM KODU ORDERING CODE		KATER ÖLÇÜLERİ DIMENSIONS (mm)				KESİCİ UÇ INSERT	YEDEK PARÇALAR / SPARE PARTS
		h	b	L	f		PİM / PINTLE
TKCN	25 25 2	25	25	150	44		 VTP 005

TEKNİK ÇİZİM / TECHNICAL DRAWING

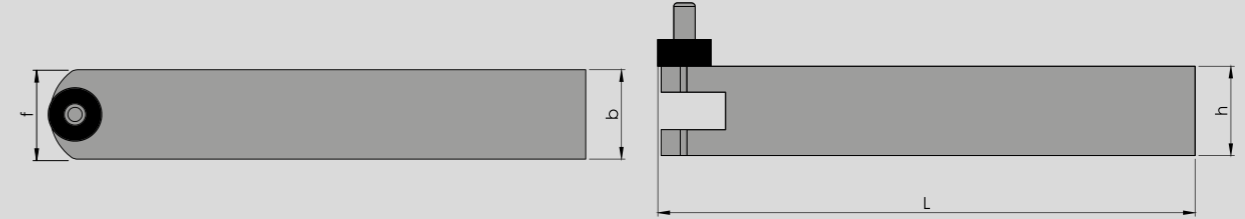

TAKIM KODU ORDERING CODE		KATER ÖLÇÜLERİ DIMENSIONS (mm)				KESİCİ UÇ INSERT	YEDEK PARÇALAR / SPARE PARTS
		h	b	L	f		PİM / PINTLE
TKTN	25 25 1	25	25	150	25		 VTP 005

 **VORGEN®**

The red power for
the professionals
Profesyoneller için
KIRMIZI GÜÇ

D SİSTEM DELİK
TORNA KATERLERİ
D System boring bars

www.vorgen.com

DD-NR ÜRÜN / PRODUCT 62,5°

TEKNİK ÇİZİM / TECHNICAL DRAWING

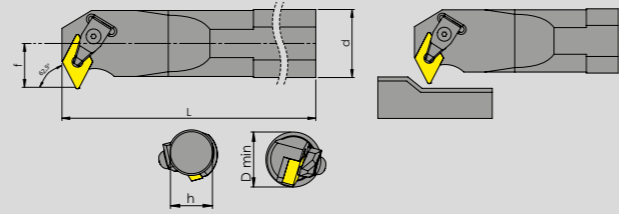

TAKIM KODU ORDERING CODE			KATER ÖLÇÜLERİ DIMENSIONS (mm)					KESİCİ UÇ INSERT	YEDEK PARÇALAR / SPARE PARTS					
			d	h	L	f	Dmin		BASKI PARÇASI WEDGE CLAMP	BASKI VİDASI SCREW	ALTLIK SHIM	ALTLIK VİDASI SHIM SCREW	YAY SPRING	ANAHTAR ALLEN KEY
S32T	DD-NR/L	15	32	30	300	22	44	DNM.. 15 06..	VPD 02	VRV 02 M6	VRDN 15	VAV 02 M5	VRY 01	AA3
S40U	DD-NR/L	15	40	37,5	350	29	52							
S50V	DD-NR/L	15	50	47	420	36	67							

DDUNR ÜRÜN / PRODUCT 93°

TEKNİK ÇİZİM / TECHNICAL DRAWING

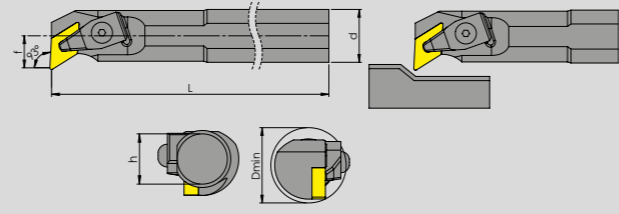

TAKIM KODU ORDERING CODE			KATER ÖLÇÜLERİ DIMENSIONS (mm)					KESİCİ UÇ INSERT	YEDEK PARÇALAR / SPARE PARTS					
			d	h	L	f	Dmin		BASKI PARÇASI WEDGE CLAMP	BASKI VİDASI SCREW	ALTLIK SHIM	ALTLIK VİDASI SHIM SCREW	YAY SPRING	ANAHTAR ALLEN KEY
S20R	DDUNR/L	11	20	18	200	13	25	DNM.. 11 04..	VDP 01	VRV 01 M5	VRDC 11	VAV 03 M4	VRY 01	AA3
S25S	DDUNR/L	11	25	23	250	17	32							
S25S	DDUNR/L	15	25	23	250	17	32	DNM.. 15 06..	VDP 02	VRV 02 M6	VRDN 11	VAV 02 M5	VRY 01	AA3
S32T	DDUNR/L	15	32	30	300	22	40							
S40U	DDUNR/L	15	40	37,5	350	27	50							
S50V	DDUNR/L	15	50	47	420	35	63							

DDQNR ÜRÜN / PRODUCT 107,5°

TEKNİK ÇİZİM / TECHNICAL DRAWING

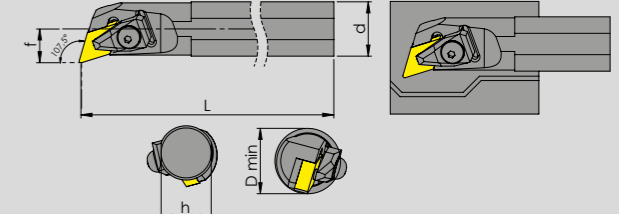

TAKIM KODU ORDERING CODE			KATER ÖLÇÜLERİ DIMENSIONS (mm)					KESİCİ UÇ INSERT	YEDEK PARÇALAR / SPARE PARTS					
			d	h	L	f	Dmin		BASKI PARÇASI WEDGE CLAMP	BASKI VİDASI SCREW	ALTLIK SHIM	ALTLIK VİDASI SHIM SCREW	YAY SPRING	ANAHTAR ALLEN KEY
S20R	DDQNR/L	11	20	18	200	13	25	DNM.. 11 04..	VDP 01	VRV 01 M5	VRDC 11	VAV 03 M4	VRY 01	AA3
S25S	DDQNR/L	11	25	23	250	17	32							
S25S	DDQNR/L	15	25	23	250	17	32	DNM.. 15 06..	VDP 02	VRV 02 M6	VRDN 15	VAV 02 M5	VRY 01	AA3
S32T	DDQNR/L	15	32	30	300	22	40							
S40U	DDQNR/L	15	40	37	350	27	50							
S50V	DDQNR/L	15	50	47	420	35	63							

DCLNR ÜRÜN / PRODUCT 95°

TEKNİK ÇİZİM / TECHNICAL DRAWING

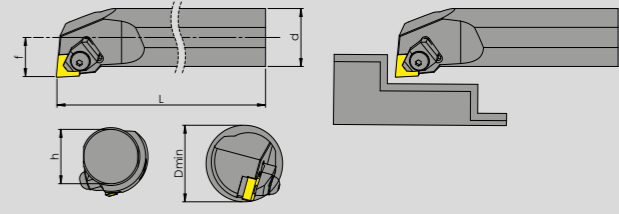

TAKIM KODU ORDERING CODE			KATER ÖLÇÜLERİ DIMENSIONS (mm)					KESİCİ UÇ INSERT	YEDEK PARÇALAR / SPARE PARTS					
			d	h	L	f	Dmin		BASKI PARÇASI WEDGE CLAMP	BASKI VİDASI SCREW	ALTLIK SHIM	ALTLIK VİDASI SHIM SCREW	YAY SPRING	ANAHTAR ALLEN KEY
S20R	DCLNR/L	12	20	18	200	13	25	CNM.. 12 04..	VDP 02	VRV 01 M6	VRDC 11	VAV 03 M4	VRY 01	AA3
S25S	DCLNR/L	12	25	23	250	17	32							
S32T	DCLNR/L	12	32	30	300	22	40	CNM.. 12 04..	VDP 02	VRV 02 M6	VRCN 12	VAV 02 M5	VRY 01	AA3
S40U	DCLNR/L	12	40	37	350	27	50							
S50V	DCLNR/L	12	50	47	420	35	63							
S32T	DCLNR/L	16	32	30	300	22	40							
S40U	DCLNR/L	16	40	37	350	27	50	CNM.. 16 06..	VDP 04	VRV 03 M6	VRCN 15	VAV 04 M5	VRY 02	AA3
S50V	DCLNR/L	16	50	47	420	35	63							

DSKNR ÜRÜN / PRODUCT 75°

TEKNİK ÇİZİM / TECHNICAL DRAWING

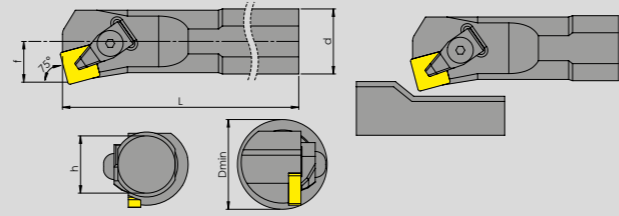

TAKIM KODU ORDERING CODE			KATER ÖLÇÜLERİ DIMENSIONS (mm)					KESİCİ UÇ INSERT	YEDEK PARÇALAR / SPARE PARTS					
									BASKI PARÇASI WEDGE CLAMP	BASKI VİDASI SCREW	ALTLIK SHIM	ALTLIK VİDASI SHIM SCREW	YAY SPRING	ANAHTAR ALLEN KEY
			d	h	L	f	Dmin							
S25S	DSKNR/L	12	25	23	250	17	32	SNM.. 12 04..	VDP 02	VRV 02 M6	VRSN 12	VAV 02 M5	VRY 01	AA3
S32T	DSKNR/L	12	32	30	300	22	40							
S40U	DSKNR/L	12	40	37	350	27	50							

DVQNR ÜRÜN / PRODUCT 117,5°

TEKNİK ÇİZİM / TECHNICAL DRAWING

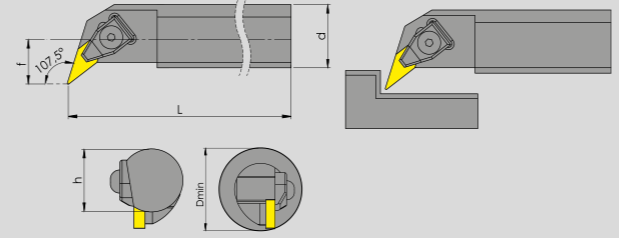

TAKIM KODU ORDERING CODE			KATER ÖLÇÜLERİ DIMENSIONS (mm)					KESİCİ UÇ INSERT	YEDEK PARÇALAR / SPARE PARTS					
									BASKI PARÇASI WEDGE CLAMP	BASKI VİDASI SCREW	ALTLIK SHIM	ALTLIK VİDASI SHIM SCREW	YAY SPRING	ANAHTAR ALLEN KEY
			d	h	L	f	Dmin							
S25S	DVQNR/L	16	25	23	250	20	32	VNM.. 16 04..	VDP 03	VRV 02 M6	VRVB 16	VAV 02 M5	VRY 01	AA3
S32T	DVQNR/L	16	32	30	300	22	40							
S40U	DVQNR/L	16	40	37,5	350	27	50							

DWLR ÜRÜN / PRODUCT 95°

TEKNİK ÇİZİM / TECHNICAL DRAWING

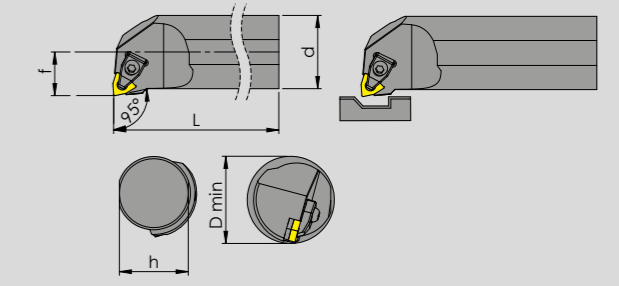

TAKIM KODU ORDERING CODE			KATER ÖLÇÜLERİ DIMENSIONS (mm)					KESİCİ UÇ INSERT	YEDEK PARÇALAR / SPARE PARTS					
									BASKI PARÇASI WEDGE CLAMP	BASKI VİDASI SCREW	ALTLIK SHIM	ALTLIK VİDASI SHIM SCREW	YAY SPRING	ANAHTAR ALLEN KEY
			d	h	L	f	Dmin							
S20R	DWLR/L	06	20	18	200	13	25	WNM.. 06 04..	VDP 01	VRV 01 M5			VRY 01	AA3
S25S	DWLR/L	06	25	23	250	17	32							
S32T	DWLR/L	06	32	30	300	22	40							
S25S	DWLR/L	08	25	23	250	17	32	WNM.. 08 04..	VDP 02	VRV 02 M6	VRWN 08	VAV 02 M5	VRY 01	AA3
S32T	DWLR/L	08	32	30	300	22	40							
S40U	DWLR/L	08	40	37	350	27	50							
S50V	DWLR/L	08	50	47	420	35	63							

DTUNR ÜRÜN / PRODUCT 93°

TEKNİK ÇİZİM / TECHNICAL DRAWING

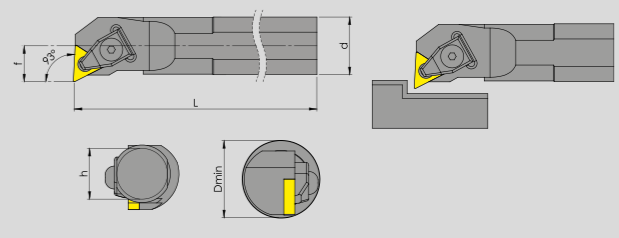

TAKIM KODU ORDERING CODE			KATER ÖLÇÜLERİ DIMENSIONS (mm)					KESİCİ UÇ INSERT	YEDEK PARÇALAR / SPARE PARTS					
									BASKI PARÇASI WEDGE CLAMP	BASKI VİDASI SCREW	ALTLIK SHIM	ALTLIK VİDASI SHIM SCREW	YAY SPRING	ANAHTAR ALLEN KEY
			d	h	L	f	Dmin							
S25S	DTUNR/L	16	25	23	250	17	32	TNM.. 16 04..	VDP 01	VRV 01 M5	VRTN 16	VAV 02 M5	VRY 01	AA3
S32T	DTUNR/L	16	32	30	300	22	40							
S40U	DTUNR/L	16	40	37	350	27	50							
S25S	DTUNR/L	22	25	23	250	17	32	TNM.. 22 04..	VDP 02	VRV 02 M6	VRTN 22	VAV 04 M6	VRY 01	AA3
S32T	DTUNR/L	22	32	30	300	22	40							
S40U	DTUNR/L	22	40	37	350	27	50							
S50V	DTUNR/L	22	50	47	420	35	63							

DVUNR ÜRÜN / PRODUCT 93°

TEKNİK ÇİZİM / TECHNICAL DRAWING

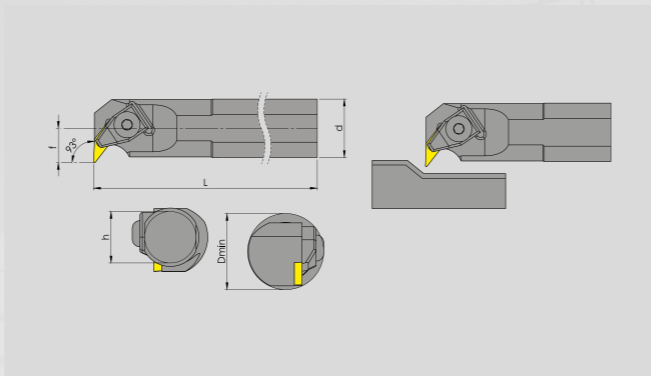

TAKIM KODU ORDERING CODE	KATER ÖLÇÜLERİ DIMENSIONS (mm)						KESİCİ UÇ INSERT	YEDEK PARÇALAR / SPARE PARTS					
	d	h	L	f	Dmin	BASKI PARÇASI WEDGE CLAMP		BASKI VIDASI SCREW	ALTLIK SHIM	ALTLIK VIDASI SHIM SCREW	YAY SPRING	ANAHTAR ALLEN KEY	
S25S DVUNR/L 16	25	23	250	20	32	VNM.. 16 04..	VDP 03	VRV 02 M6	VRVB 16	VAV 02 M5	VRY 01	AA3	
S32T DVUNR/L 16	32	30	300	22	40								
S40U DVUNR/L 16	40	37,5	350	27	50								



The red power for the professionals
Profesyoneller için
Kırmızı Güç

M SİSTEM DELİK TORNA KATERLERİ
M System boring bars

www.vorgen.com

MTUNR ÜRÜN / PRODUCT 93°

TEKNİK ÇİZİM / TECHNICAL DRAWING

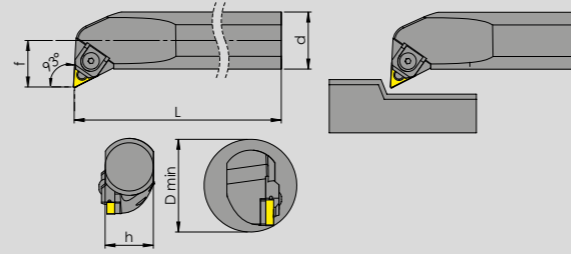

TAKIM KODU ORDERING CODE	KATER ÖLÇÜLERİ DIMENSIONS (mm)					KESİCİ UÇ INSERT	YEDEK PARÇALAR / SPARE PARTS						
	d	h	L	f	Dmin		BASKI PARÇASI WEDGE CLAMP	BASKI VİDASI SCREW	ALTLIK SHIM	ALTLIK VİDASI SHIM SCREW	YAY SPRING	ANAHTAR ALLEN KEY	
S20R MTUNR/L	16	20	18	200	13	25	TNM.. 16 04..	VMP 03	VRV 01 M5		VAV 08 M5	VRV 01	AA3
S25S MTUNR/L	16	25	23	250	17	32	TNM.. 16 04..	VMP 03	VRV 01 M5	VRTN 16	VAV 08 M5	VRV 01	AA3
S32T MTUNR/L	16	32	30	300	22	40							
S40U MTUNR/L	16	40	37	350	27	50							
S25S MTUNR/L	22	25	23	250	17	32	TNM.. 22 04..	VMP 04	VRV 02 M6	VRTN 22	VAV 10 M6	VRV 01	AA3
S32T MTUNR/L	22	32	30	300	22	40							
S40U MTUNR/L	22	40	37	350	27	50							
S50V MTUNR/L	22	50	47	420	35	63							

MT-NR/L ÜRÜN / PRODUCT 60°

TEKNİK ÇİZİM / TECHNICAL DRAWING

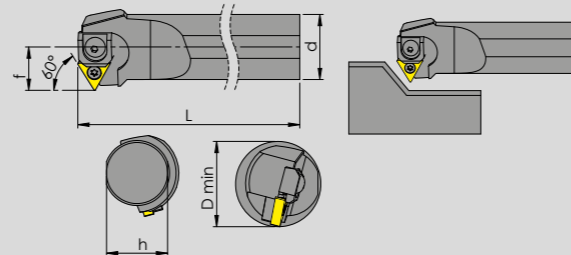

TAKIM KODU ORDERING CODE	KATER ÖLÇÜLERİ DIMENSIONS (mm)					KESİCİ UÇ INSERT	YEDEK PARÇALAR / SPARE PARTS						
	d	h	L	f	Dmin		BASKI PARÇASI WEDGE CLAMP	BASKI VİDASI SCREW	ALTLIK SHIM	ALTLIK VİDASI SHIM SCREW	YAY SPRING	ANAHTAR ALLEN KEY	
S25S MT-NR/L	16	25	23	250	17	32	TNM.. 16 04..	VMP 03	VRV 01 M5	VRTN 16	VAV 08 M5	VRV 01	AA3
S32T MT-NR/L	16	32	30	300	22	40	TNM.. 22 04..	VMP 04	VRV 02 M6	VRTN 22	VAV 10 M6	VRV 01	AA3
S40U MT-NR/L	22	40	37	350	27	50							
S50V MT-NR/L	22	50	47	420	35	63							

MTQNR ÜRÜN / PRODUCT 107,5°

TEKNİK ÇİZİM / TECHNICAL DRAWING

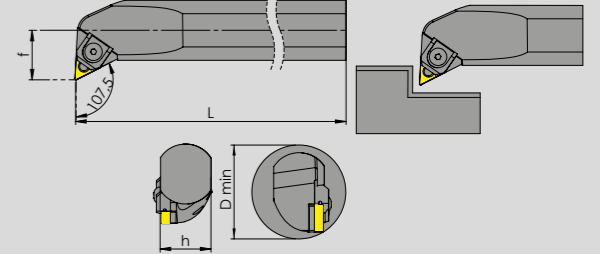

TAKIM KODU ORDERING CODE	KATER ÖLÇÜLERİ DIMENSIONS (mm)					KESİCİ UÇ INSERT	YEDEK PARÇALAR / SPARE PARTS						
	d	h	L	f	Dmin		BASKI PARÇASI WEDGE CLAMP	BASKI VİDASI SCREW	ALTLIK SHIM	ALTLIK VİDASI SHIM SCREW	YAY SPRING	ANAHTAR ALLEN KEY	
S20R MTQNR/L	16	20	18	200	13	25	TNM.. 16 04..	VMP 03	VRV 01 M5		VAV 08 M5	VRV 01	AA3
S25S MTQNR/L	16	25	23	250	17	32	TNM.. 16 04..	VMP 03	VRV 01 M5	VRTN 16	VAV 08 M5	VRV 01	AA3
S32T MTQNR/L	16	32	30	300	22	40							
S40U MTQNR/L	16	40	37	350	27	50							
S25S MTQNR/L	22	25	23	250	17	32	TNM.. 22 04..	VMP 04	VRV 02 M6	VRTN 22	VAV 10 M6	VRV 01	AA3
S32T MTQNR/L	22	32	30	300	22	40							
S40U MTQNR/L	22	40	37	350	27	50							
S50V MTQNR/L	22	50	47	420	35	63							

MWLNr ÜRÜN / PRODUCT 95°

TEKNİK ÇİZİM / TECHNICAL DRAWING

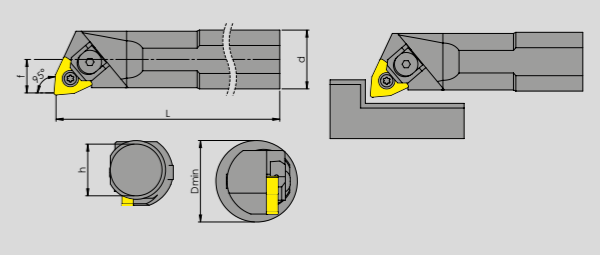

TAKIM KODU ORDERING CODE	KATER ÖLÇÜLERİ DIMENSIONS (mm)					KESİCİ UÇ INSERT	YEDEK PARÇALAR / SPARE PARTS						
	d	h	L	f	Dmin		BASKI PARÇASI WEDGE CLAMP	BASKI VİDASI SCREW	ALTLIK SHIM	ALTLIK VİDASI SHIM SCREW	YAY SPRING	ANAHTAR ALLEN KEY	
S20R MWLNr/L	06	20	18	200	13	25	WNM.. 06 04..	VMP 01	VRV 01 M5		VAV 08 M5	VRV 01	AA3
S25S MWLNr/L	06	25	23	250	17	32							
S32T MWLNr/L	06	32	30	300	22	40							
S25S MWLNr/L	08	25	23	250	17	32	TNM.. 08 04..	VMP 02	VRV 02 M6	VRWN 08	VAV 10 M6	VRV 01	AA3
S32T MWLNr/L	08	32	30	300	22	40							
S40U MWLNr/L	08	40	37	350	27	50							
S50V MWLNr/L	08	50	47	420	35	63							

MTFNR ÜRÜN / PRODUCT 90°

TEKNİK ÇİZİM / TECHNICAL DRAWING

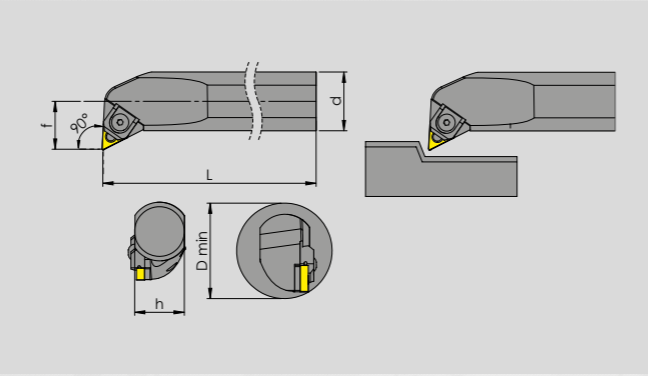

TAKIM KODU ORDERING CODE	KATER ÖLÇÜLERİ DIMENSIONS (mm)						KESİCİ UÇ INSERT	YEDEK PARÇALAR / SPARE PARTS						
	d	h	L	f	Dmin	BASKI PARÇASI WEDGE CLAMP		BASKI VIDASI SCREW	ALTLIK SHIM	ALTLIK VIDASI SHIM SCREW	YAY SPRING	ANAHTAR ALLEN KEY		
S20R	MTFNR/L	16	20	18	200	13	25	TNM.. 16 04..	VMP 03	VRV 01 M5		VAV 08 M5	VRY 01	AA3
S25S	MTFNR/L	16	25	23	250	17	32	TNM.. 16 04..	VMP 03	VRV 01 M5	VRTN 16	VAV 08 M5	VRY 01	AA3
S32T	MTFNR/L	16	32	30	300	22	40	TNM.. 16 04..	VMP 03	VRV 01 M5	VRTN 16	VAV 08 M5	VRY 01	AA3
S40U	MTFNR/L	16	40	37	350	27	50	TNM.. 16 04..	VMP 03	VRV 01 M5	VRTN 16	VAV 08 M5	VRY 01	AA3
S25S	MTFNR/L	22	25	23	250	17	32	TNM.. 22 04..	VMP 04	VRV 02 M6	VRTN 22	VAV 10 M6	VRY 01	AA3
S32T	MTFNR/L	22	32	30	300	22	40	TNM.. 22 04..	VMP 04	VRV 02 M6	VRTN 22	VAV 10 M6	VRY 01	AA3
S40U	MTFNR/L	22	40	37	350	27	50	TNM.. 22 04..	VMP 04	VRV 02 M6	VRTN 22	VAV 10 M6	VRY 01	AA3
S50V	MTFNR/L	22	50	47	420	35	63	TNM.. 22 04..	VMP 04	VRV 02 M6	VRTN 22	VAV 10 M6	VRY 01	AA3



The red power for the professionals
Profesyoneller için
Kırmızı Güç



C SİSTEM DELİK
TORNA KATERLERİ
C System boring bars

www.vorgen.com

CKUNR/L ÜRÜN / PRODUCT

93°



TEKNİK ÇİZİM / TECHNICAL DRAWING

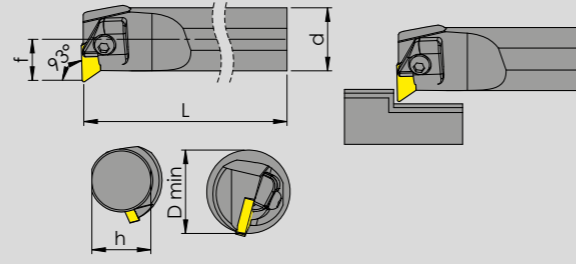

TAKIM KODU ORDERING CODE	KATER ÖLÇÜLERİ DIMENSIONS (mm)					KESİCİ UÇ INSERT	YEDEK PARÇALAR / SPARE PARTS							
	d	h	L	f	Dmin		BASKI PARÇASI WEDGE CLAMP	BASKI VIDASI SCREW	ALTLIK SHIM	ALTLIK VIDASI SHIM SCREW	YAY SPRING	ANAHTAR ALLEN KEY		
S25S	CKUNR/L	16	25	23	250	19	38	KNUX.. 16 R/L	VCP 01	VRV 04 M6	VRKN 16 R/L	VAV 01 M3	VRY 02	AA4
S28T	CKUNR/L	16	28	26	290	19	38							
S32T	CKUNR/L	16	32	30	330	22	40							
S40U	CKUNR/L	16	40	37	400	27	50							
S45V	CKUNR/L	16	45	42	400	29	52							
S50V	CKUNR/L	16	50	47	420	35	63							

CTFPR/L ÜRÜN / PRODUCT

91°



TEKNİK ÇİZİM / TECHNICAL DRAWING

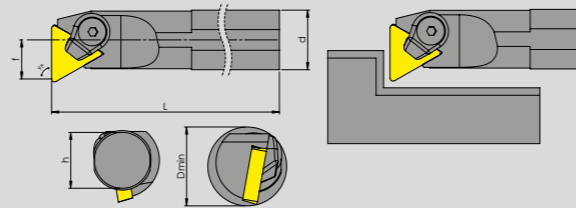

TAKIM KODU ORDERING CODE	KATER ÖLÇÜLERİ DIMENSIONS (mm)					KESİCİ UÇ INSERT	YEDEK PARÇALAR / SPARE PARTS							
	d	h	L	f	Dmin		BASKI PARÇASI WEDGE CLAMP	BASKI VIDASI SCREW	ALTLIK SHIM	ALTLIK VIDASI SHIM SCREW	YAY SPRING	ANAHTAR TORX KEY		
S12Q	CTFPR/L	11	12	11	125	9	16	TP. 11 03..	VCP 01	VRT 06 M3,5x9				T15
S16R	CTFPR/L	16	16	15	180	11	20	TP. 16 03..	VCP 03	VRT 06 M3,5x9	VRTC 16	VAV 06 M5.05		T15
S20R	CTFPR/L	16	20	18	190	13	25							
S25S	CTFPR/L	16	25	23	250	17	32	TP. 22 04..	VCP 03	VRT 06 M3,5x9	VRTC 22	VAV 07 M6		T15
S25S	CTFPR/L	22	25	23	250	17	32							
S32T	CTFPR/L	22	32	30	300	27	40							

S SİSTEM DELİK
TORNA KATERLERİ
S System boring bars

www.vorgen.com

The red power for
the professionals
Profesyoneller için
Kırmızı Güç

SDUCR ÜRÜN / PRODUCT 93°

TEKNİK ÇİZİM / TECHNICAL DRAWING

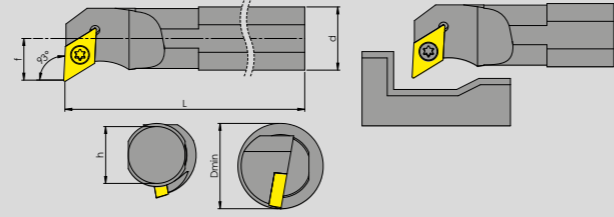

TAKIM KODU ORDERING CODE	KATER ÖLÇÜLERİ DIMENSIONS (mm)					KESİCİ UÇ INSERT	YEDEK PARÇALAR / SPARE PARTS			
	d	h	L	f	Dmin		BASKI VIDASI SCREW	ALTLIK SHIM	ALTLIK VIDASI SHIM SCREW	ANAHTAR TORX KEY
S10J	SDUCR/L	07	10	9	120	7	13	DCM.. 07 02..	VRT 03 M2,5x5	T08
S12K	SDUCR/L	07	12	11	125	9	16			
S10-16P	SDUCR/L	07	10-16	15	150	6	14			
S12-16P	SDUCR/L	07	12-16	15	150	8	16			
S16Q	SDUCR/L	07	16	15	180	11	20	DCM.. 11 T3..	VRT 06 M3,5x9	T15
S16Q	SDUCR/L	11	16	15	180	11	20			
S20R	SDUCR/L	11	20	18	200	13	25	DCM.. 11 T3..	VRT 06 M3,5x9	T15
S25S	SDUCR/L	11	25	23	250	17	32			
S32T	SDUCR/L	11	32	30	300	22	40			

SDQCR ÜRÜN / PRODUCT 107,5°

TEKNİK ÇİZİM / TECHNICAL DRAWING

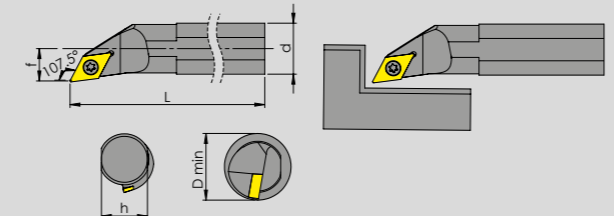

TAKIM KODU ORDERING CODE	KATER ÖLÇÜLERİ DIMENSIONS (mm)					KESİCİ UÇ INSERT	YEDEK PARÇALAR / SPARE PARTS			
	d	h	L	f	Dmin		BASKI VIDASI SCREW	ALTLIK SHIM	ALTLIK VIDASI SHIM SCREW	ANAHTAR TORX KEY
S10J	SDQCR/L	07	10	9	120	7	13	DCM.. 07 02..	VRT 03 M2,5x5	T08
S12K	SDQCR/L	07	12	11	125	9	16			
S16Q	SDQCR/L	07	16	15	180	11	20			
S16Q	SDQCR/L	11	16	15	180	11	20	DCM.. 11 T3..	VRT 06 M3,5x9	T15
S20R	SDQCR/L	11	20	18	200	13	25			
S25S	SDQCR/L	11	25	23	250	17	32	DCM.. 11 T3..	VRT 06 M3,5x9	T15
S32T	SDQCR/L	11	32	30	300	22	40			

SD-CR ÜRÜN / PRODUCT 62,5°

TEKNİK ÇİZİM / TECHNICAL DRAWING

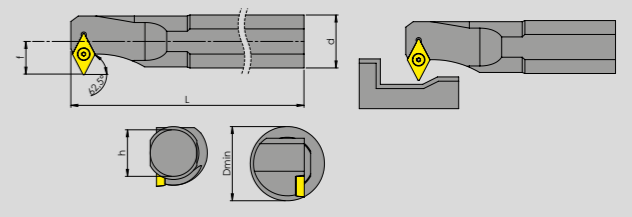

TAKIM KODU ORDERING CODE	KATER ÖLÇÜLERİ DIMENSIONS (mm)					KESİCİ UÇ INSERT	YEDEK PARÇALAR / SPARE PARTS			
	d	h	L	f	Dmin		BASKI VIDASI SCREW	ALTLIK SHIM	ALTLIK VIDASI SHIM SCREW	ANAHTAR TORX KEY
S10J	SD-CR/L	07	10	9	120	7	13	DCM.. 07 02..	VRT 03 M2,5x5	T08
S12K	SD-CR/L	07	12	11	125	9	16			
S16Q	SD-CR/L	07	16	15	180	11	20			
S16Q	SD-CR/L	11	16	15	180	11	20	DCM.. 11 T3..	VRT 06 M3,5x9	T15
S20R	SD-CR/L	11	20	18	200	13	25			
S25S	SD-CR/L	11	25	23	250	17	32	DCM.. 11 T3..	VRT 06 M3,5x9	T15
S32T	SD-CR/L	11	32	30	300	22	40			

SDZCR ÜRÜN / PRODUCT 93°

TEKNİK ÇİZİM / TECHNICAL DRAWING

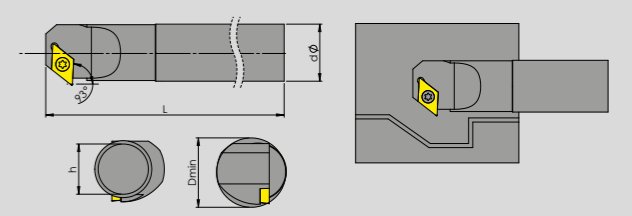

TAKIM KODU ORDERING CODE	KATER ÖLÇÜLERİ DIMENSIONS (mm)					KESİCİ UÇ INSERT	YEDEK PARÇALAR / SPARE PARTS			
	d	h	L	f	Dmin		BASKI VIDASI SCREW	ALTLIK SHIM	ALTLIK VIDASI SHIM SCREW	ANAHTAR TORX KEY
S12K	SDZCR/L	07	12	11	125	9	16	DCM.. 07 02..	VRT 03 M2,5x5	T08
S16Q	SDZCR/L	07	16	15	180	11	20			
S16Q	SDZCR/L	11	16	15	180	11	20			
S20R	SDZCR/L	11	20	18	200	13	25	DCM.. 11 T3..	VRT 06 M3,5x9	T15
S25S	SDZCR/L	11	25	23	250	17	32			
S32T	SDZCR/L	11	32	30	300	22	40	DCM.. 11 T3..	VRT 06 M3,5x9	T15

SDXCR ÜRÜN / PRODUCT 117,5°

TEKNİK ÇİZİM / TECHNICAL DRAWING

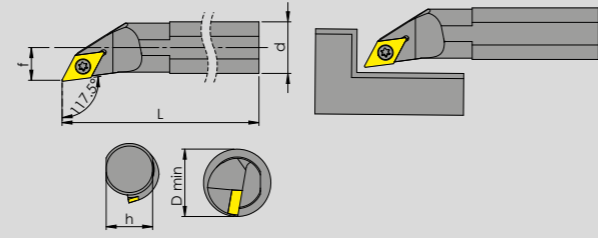

TAKIM KODU ORDERING CODE	KATER ÖLÇÜLERİ DIMENSIONS (mm)					KESİCİ UÇ INSERT	YEDEK PARÇALAR / SPARE PARTS					
	d	h	L	f	Dmin		BASKI VIDASI SCREW	ALTLIK SHIM	ALTLIK VIDASI SHIM SCREW	ANAHTAR TORX KEY		
S12K	SDXCR/L	07	10	9	120	7	13	DCM.. 07 02..	VRT 03 M2,5x5			T08
S16Q	SDXCR/L	07	12	11	125	9	16					
S16Q	SDXCR/L	07	16	15	180	11	20					
S20R	SDXCR/L	11	16	15	180	11	20	DCM.. 11 T3..	VRT 06 M3,5x9	VRDC 11	VAV 06 M5.05	T15
S25S	SDXCR/L	11	20	18	200	13	25					

STUPR ÜRÜN / PRODUCT 93°

TEKNİK ÇİZİM / TECHNICAL DRAWING

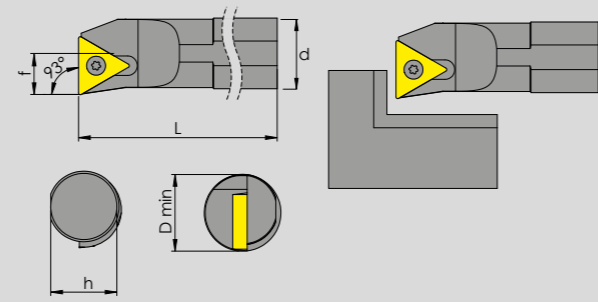

TAKIM KODU ORDERING CODE	KATER ÖLÇÜLERİ DIMENSIONS (mm)					KESİCİ UÇ INSERT	YEDEK PARÇALAR / SPARE PARTS					
	d	h	L	f	Dmin		BASKI VIDASI SCREW	ALTLIK SHIM	ALTLIK VIDASI SHIM SCREW	ANAHTAR TORX KEY		
S10J	STUPR/L	11	12	11	125	9	16	TPM.. 11 03..	VRT 05 M3x8			T10
S12K	STUPR/L	11	12	11	125	9	16					
S16Q	STUPR/L	11	16	15	180	11	20					
S20R	STUPR/L	11	20	18	200	13	25					

SVUBR ÜRÜN / PRODUCT 93°

TEKNİK ÇİZİM / TECHNICAL DRAWING

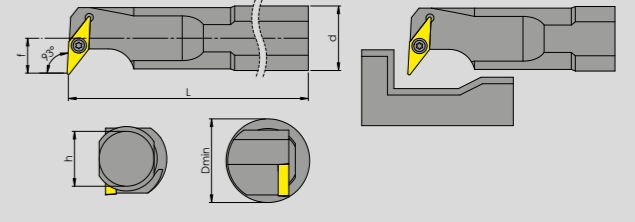

TAKIM KODU ORDERING CODE	KATER ÖLÇÜLERİ DIMENSIONS (mm)					KESİCİ UÇ INSERT	YEDEK PARÇALAR / SPARE PARTS					
	d	h	L	f	Dmin		BASKI VIDASI SCREW	ALTLIK SHIM	ALTLIK VIDASI SHIM SCREW	ANAHTAR TORX KEY		
S16Q	SVUBR/L	11	16	15	180	11	20	VBM.. 11 03..	VRT 03 M2,5x5			T08
S20R	SVUBR/L	11	20	18	200	13	25					
S25S	SVUBR/L	16	25	23	250	17	32					
S32T	SVUBR/L	16	32	30	300	22	40	VBM.. 16 04..	VRT 07 M3,5x11	VRVB 16	VAV 06 M5.05	T15
S40V	SVUBR/L	16	40	37	350	27	50					

SVUCR ÜRÜN / PRODUCT 93°

TEKNİK ÇİZİM / TECHNICAL DRAWING

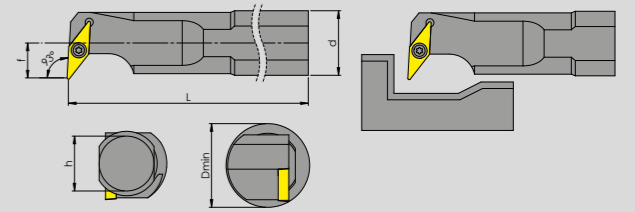

TAKIM KODU ORDERING CODE	KATER ÖLÇÜLERİ DIMENSIONS (mm)					KESİCİ UÇ INSERT	YEDEK PARÇALAR / SPARE PARTS					
	d	h	L	f	Dmin		BASKI VIDASI SCREW	ALTLIK SHIM	ALTLIK VIDASI SHIM SCREW	ANAHTAR TORX KEY		
S16Q	SVUCR/L	11	16	15	180	11	20	VCM.. 11 03..	VRT 04 M2,5x5			T08
S20R	SVUCR/L	11	20	18	200	13	25					
S25S	SVUCR/L	16	25	23	250	17	32					
S32T	SVUCR/L	16	32	30	300	22	40	VCM.. 16 04..	VRT 07 M3,5x11	VRVB 16	VAV 06 M5.05	T15
S40V	SVUCR/L	16	40	37	350	27	50					

SVQBR ÜRÜN / PRODUCT 107,5°

TEKNİK ÇİZİM / TECHNICAL DRAWING

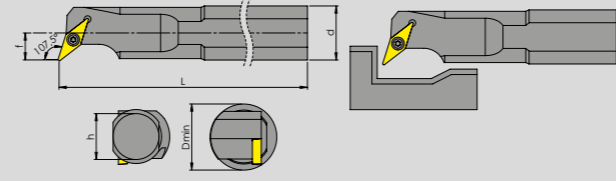

TAKIM KODU ORDERING CODE	KATER ÖLÇÜLERİ DIMENSIONS (mm)					KESİCİ UÇ INSERT	YEDEK PARÇALAR / SPARE PARTS					
	d	h	L	f	Dmin		BASKI VİDASI SCREW	ALTLIK SHIM	ALTLIK VİDASI SHIM SCREW	ANAHTAR TORX KEY		
S16Q	SVQBR/L	11	16	15	180	11	20	VBM.. 11 03..	VRT 04 M2,5x5	VRVB 16	VAV 06 M5.05	T08
S20R	SVQBR/L	11	20	18	200	13	25					
S25S	SVQBR/L	16	25	23	250	17	32	VBM.. 16 04..	VRT 07 M3,5x11	VRVB 16	VAV 06 M5.05	T15
S32T	SVQBR/L	16	32	30	300	22	40					
S40V	SVQBR/L	16	40	37	350	27	50					

SVQCR ÜRÜN / PRODUCT 107,5°

TEKNİK ÇİZİM / TECHNICAL DRAWING

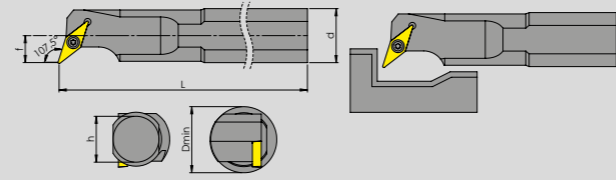

TAKIM KODU ORDERING CODE	KATER ÖLÇÜLERİ DIMENSIONS (mm)					KESİCİ UÇ INSERT	YEDEK PARÇALAR / SPARE PARTS					
	d	h	L	f	Dmin		BASKI VİDASI SCREW	ALTLIK SHIM	ALTLIK VİDASI SHIM SCREW	ANAHTAR TORX KEY		
S16Q	SVQCR/L	11	16	15	180	11	20	VCM.. 11 03..	VRT 04 M2,5x5	VRVB 16	VAV 06 M5.05	T08
S20R	SVQCR/L	11	20	18	200	13	25					
S25S	SVQCR/L	16	25	23	250	17	32	VCM.. 16 04..	VRT 07 M3,5x11	VRVB 16	VAV 06 M5.05	T15
S32T	SVQCR/L	16	32	30	300	22	40					
S40V	SVQCR/L	16	40	37	350	27	50					

STFCR ÜRÜN / PRODUCT 90°

TEKNİK ÇİZİM / TECHNICAL DRAWING

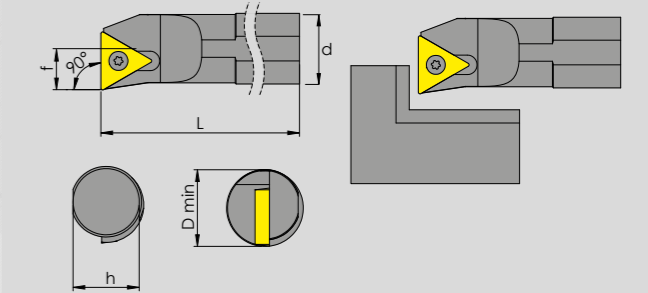

TAKIM KODU ORDERING CODE	KATER ÖLÇÜLERİ DIMENSIONS (mm)					KESİCİ UÇ INSERT	YEDEK PARÇALAR / SPARE PARTS					
	d	h	L	f	Dmin		BASKI VİDASI SCREW	ALTLIK SHIM	ALTLIK VİDASI SHIM SCREW	ANAHTAR TORX KEY		
S10J	STFCR/L	09	10	9	120	7	13	TCM.. 09 02	VRT 04 M2,5x6	VRVB 16	VAV 06 M5.05	T08
S12K	STFCR/L	09	12	11	125	9	16					
S12K	STFCR/L	11	12	11	125	9	16	TCM.. 11 02..	VRT 04 M2,5x6	VRVB 16	VAV 06 M5.05	T08
S16Q	STFCR/L	11	16	15	180	11	20					
S20R	STFCR/L	11	20	18	200	13	25					
S16Q	STFCR/L	16	16	15	180	11	20	TCM.. 16..	VRT 06 M3,5x9	VRVB 16	VAV 06 M5.05	T15
S20R	STFCR/L	16	20	18	200	13	25					
S25S	STFCR/L	16	25	23	250	17	32					
S32T	STFCR/L	16	32	30	300	22	40	TCM.. 16..	VRT 06 M3,5x9	VRTC 16	VAV 06 M5	T15

ST-CR ÜRÜN / PRODUCT 60°

TEKNİK ÇİZİM / TECHNICAL DRAWING

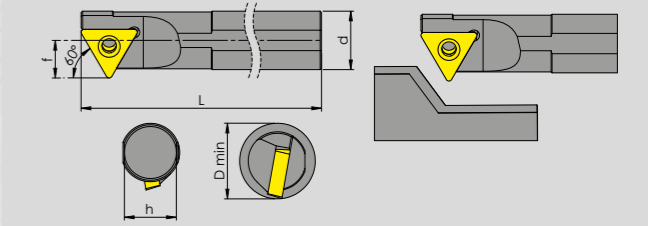

TAKIM KODU ORDERING CODE	KATER ÖLÇÜLERİ DIMENSIONS (mm)					KESİCİ UÇ INSERT	YEDEK PARÇALAR / SPARE PARTS					
	d	h	L	f	Dmin		BASKI VİDASI SCREW	ALTLIK SHIM	ALTLIK VİDASI SHIM SCREW	ANAHTAR TORX KEY		
S16Q	ST-CR/L	11	16	15	180	11	20	TC.. 16..	VRT 07 M3,5x11	VRVB 16	VAV 06 M5.05	T15
S20R	ST-CR/L	11	20	18	190	13	25					
S25S	ST-CR/L	11	25	23	250	17	32	TCM.. 16..	VRT 06 M3,5x9	VRTC 16	VAV 06 M5	T15
S32T	ST-CR/L	11	32	30	300	22	40					

SVZBR ÜRÜN / PRODUCT 93°

TEKNİK ÇİZİM / TECHNICAL DRAWING

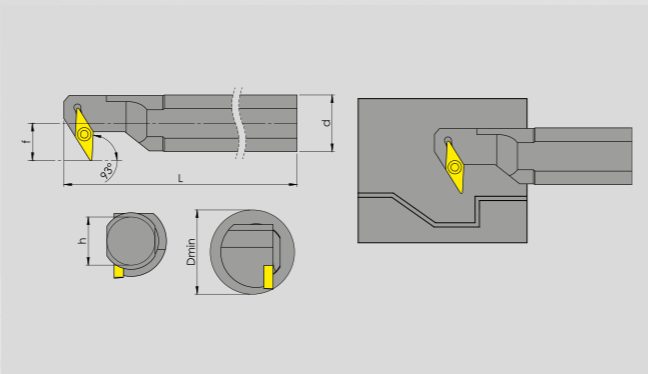

TAKIM KODU ORDERING CODE	KATER ÖLÇÜLERİ DIMENSIONS (mm)					KESİCİ UÇ INSERT	YEDEK PARÇALAR / SPARE PARTS			
	d	h	L	f	Dmin		BASKI VİDASI SCREW	ALTLIK SHIM	ALTLIK VİDASI SHIM SCREW	ANAHTAR TORX KEY
S25S SVZBR/L 16	25	23	250	17	32	VBM.. 16 04..	VRT 07 M3,5x11	VRVB 16	VAV 06 M5.05	T15
S32T SVZBR/L 16	32	30	300	22	40					
S40U SVZBR/L 16	40	37	350	27	50					

SCLCR ÜRÜN / PRODUCT 95°

TEKNİK ÇİZİM / TECHNICAL DRAWING

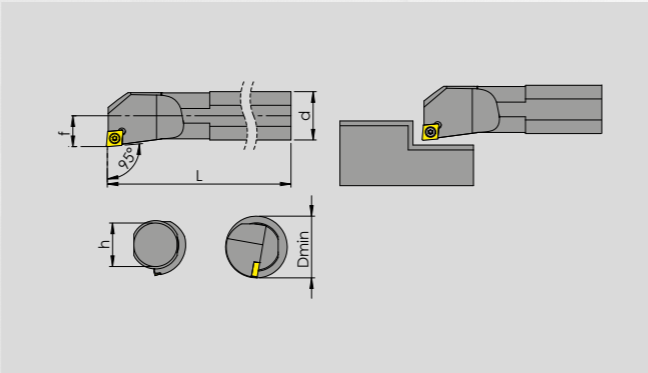

TAKIM KODU ORDERING CODE	KATER ÖLÇÜLERİ DIMENSIONS (mm)					KESİCİ UÇ INSERT	YEDEK PARÇALAR / SPARE PARTS			
	d	h	L	f	Dmin		BASKI VİDASI SCREW	ALTLIK SHIM	ALTLIK VİDASI SHIM SCREW	ANAHTAR TORX KEY
S06-08H SCLCR/L 06	06-08	7	115	4,5	8	CCM.. 06 02..	VRT 03 M2,5x5			T08
S08H SCLCR/L 06	08	7	115	6	11					
S10J SCLCR/L 06	10	9	120	7	13					
S12K SCLCR/L 06	12	11	125	9	16					
S08-16M SCLCR/L 06	08-16	15	150	6	11					
S10-16M SCLCR/L 06	10-16	15	150	7	13					
S12-16M SCLCR/L 06	12-16	15	150	9	16	CCM.. 09 T3..	VRT 06 M3,5x9			T15
S16Q SCLCR/L 09	16	15	180	11	21					
S20R SCLCR/L 09	20	18	200	13	25					
S25S SCLCR/L 09	25	23	250	17	32					
S25S SCLCR/L 12	25	23	250	17	32	CCM.. 12 04..	VRT 10 M4,5x12			T15
S32T SCLCR/L 12	32	30	300	22	40					

STUCR ÜRÜN / PRODUCT 93°

TEKNİK ÇİZİM / TECHNICAL DRAWING

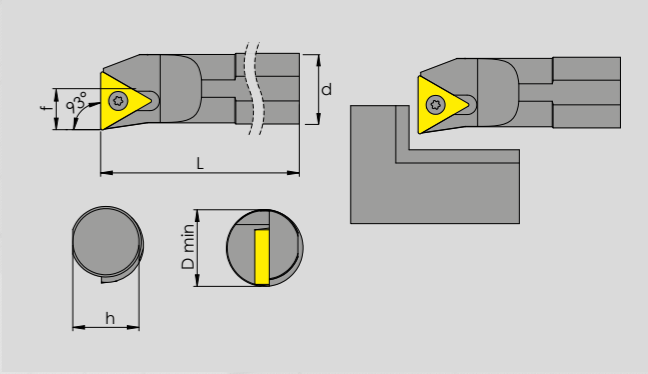

TAKIM KODU ORDERING CODE	KATER ÖLÇÜLERİ DIMENSIONS (mm)					KESİCİ UÇ INSERT	YEDEK PARÇALAR / SPARE PARTS			
	d	h	L	f	Dmin		BASKI VİDASI SCREW	ALTLIK SHIM	ALTLIK VİDASI SHIM SCREW	ANAHTAR TORX KEY
S10J STUCR/L 09	10	9	120	7	13	TCM.. 09 02	VRT 04 M2,5x6			T08
S12K STUCR/L 09	12	11	125	9	16					
S12K STUCR/L 11	12	11	125	9	16					
S16Q STUCR/L 11	16	15	180	11	20	TCM.. 11 02..	VRT 04 M2,5x6			T08
S20R STUCR/L 11	20	18	200	13	25					
S16Q STUCR/L 16	16	15	180	11	20	TCM.. 16..	VRT 06 M3,5x9			T15
S20R STUCR/L 16	20	18	200	13	25					
S25S STUCR/L 16	25	23	250	17	32					
S32T STUCR/L 16	32	30	300	22	40					
						TCM.. 16..	VRT 06 M3,5x9	VRTC 16	VAV 06 M5	T15

STFPR ÜRÜN / PRODUCT 90°

TEKNİK ÇİZİM / TECHNICAL DRAWING

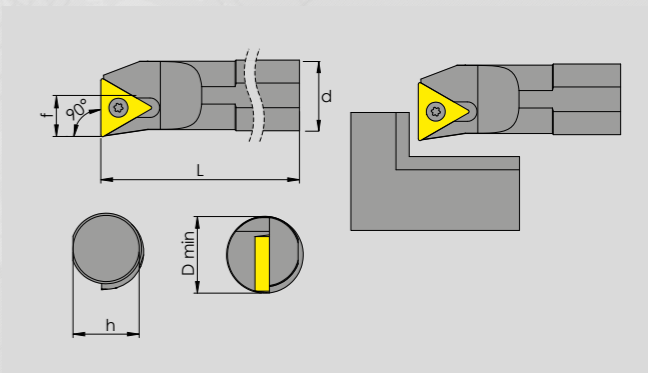

TAKIM KODU ORDERING CODE	KATER ÖLÇÜLERİ DIMENSIONS (mm)					KESİCİ UÇ INSERT	YEDEK PARÇALAR / SPARE PARTS			
	d	h	L	f	Dmin		BASKI VİDASI SCREW	ALTLIK SHIM	ALTLIK VİDASI SHIM SCREW	ANAHTAR TORX KEY
S10J STFPR/L 11	10	09	120	7	13	TPM.. 11 03..	VRT 05 M3x8			T10
S12K STFPR/L 11	12	11	125	9	16					
S16Q STFPR/L 11	16	15	180	11	20					
S20R STFPR/L 11	20	18	200	13	25					

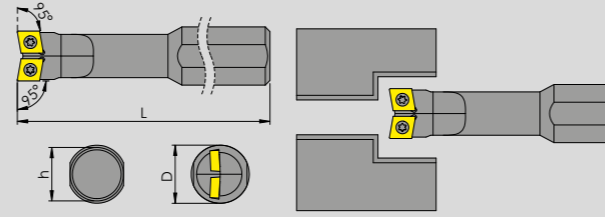

TAKIM KODU ORDERING CODE	KATER ÖLÇÜLERİ DIMENSIONS (mm)						KESİCİ UÇ INSERT	YEDEK PARÇALAR / SPARE PARTS			
	d	h	L	f	Dmin	BASKI VİDASI SCREW		ALTLIK SHIM	ALTLIK VİDASI SHIM SCREW	ANAHTAR TORX KEY	
S25S SCR-SCL 09	25	23	250	22	X						
S32T SCR-SCL 09	32	30	300	27	X						

VİDA TAKIMLARI
Screw plugs

www.vorgen.com



The red power for
the professionals
Profesyoneller için
KIRMIZI GÜÇ

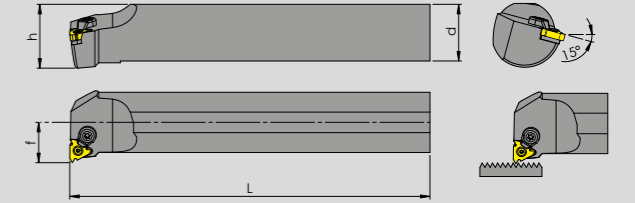

TAKIM KODU ORDERING CODE	KATER ÖLÇÜLERİ DIMENSIONS (mm)					KESİCİ UÇ INSERT	YEDEK PARÇALAR / SPARE PARTS					
	h	b	L	f			SIKMA VİDASI SCREW	ALTLIK SHIM	ALTLIK VİDASI SHIM SCREW	BASKI PARÇASI WEDGE CLAMP	BASKI VİDASI SPRING	TORX ANAHTAR TORX KEY
SER/L 1212 F11	12	12	80	11		ER/L.11	VRT 04 M2,5x5					T08
SER/L 1616 H11	16	16	100	16		ER/L.11	VRT 04 M2,5x5					T08
SER/L 1616 H16	16	16	100	16		ER/L.16	VRT 04 M2,5x5					T08
SER/L 2020 K16	20	20	125	20		ER/L.16	VRT 07 M3,5x11	VRIR 16	VAV 06 M5.05	VCP 03	VRT 10 M4,5x12	T15
SER/L 2525 M16	25	25	150	25		ER/L.16	VRT 07 M3,5x11	VRIR 16	VAV 06 M5.05	VCP 03	VRT 10 M4,5x12	T15
SER/L 3232 P16	32	32	170	32		ER/L.16	VRT 07 M3,5x11	VRIR 16	VAV 06 M5.05	VCP 03	VRT 10 M4,5x12	T15
SER/L 2525 M22	25	25	150	25		ER/L.22	VRT 09 M4x11	VRIR 22	VAV 07 M6	VCP 03	VRT 10 M4,5x12	T20
SER/L 3232 P22	32	32	170	32		ER/L.22	VRT 09 M4x11	VRIR 22	VAV 07 M6	VCP 03	VRT 10 M4,5x12	T20

TAKIM KODU ORDERING CODE	KATER ÖLÇÜLERİ DIMENSIONS (mm)					KESİCİ UÇ INSERT	YEDEK PARÇALAR / SPARE PARTS					
	d	h	L	f	Dmin		SIKMA VİDASI SCREW	ALTLIK SHIM	ALTLIK VİDASI SHIM SCREW	BASKI PARÇASI WEDGE CLAMP	BASKI VİDASI SPRING	TORX ANAHTAR TORX KEY
STIR/L S10J 11	10	9	100	7,4	12	IR/L.11	VRT 04 M2,5x5					T08
STIR/L S12K 11	12	11	125	8,4	16	IR/L.11	VRT 04 M2,5x5					T08
STIR/L S16Q 16	16	15	150	7,4	12	IR/L.16	VRT 07 M3,5x11					T15
STIR/L S20R 16	20	18	170	13,7	24	IR/L.16	VRT 07 M3,5x11	VRIR 16	VAV 06 M5.05	VCP 03	VRT 10 M4,5x12	T15
STIR/L S25S 16	25	23	250	16,2	29	IR/L.16	VRT 07 M3,5x11	VRIR 16	VAV 06 M5.05	VCP 03	VRT 10 M4,5x12	T15
STIR/L S32T 16	32	30	250	19,7	36	IR/L.16	VRT 07 M3,5x11	VRIR 16	VAV 06 M5.05	VCP 03	VRT 10 M4,5x12	T15
STIR/L S40U 16	40	37	300	23,7	44	IR/L.16	VRT 07 M3,5x11	VRIR 16	VAV 06 M5.05	VCP 03	VRT 10 M4,5x12	T15
STIR/L S20R 22	20	18	170	14	24	IR/L.22	VRT 07 M4,5x11			VCP 03	VRT 10 M4,5x12	T15
STIR/L S25S 22	25	23	250	18,1	29	IR/L.22	VRT 07 M4,5x11			VCP 03	VRT 10 M4,5x12	T15
STIR/L S32T 22	32	30	250	21,6	38	IR/L.22	VRT 07 M4,5x11	VRIR 22	VAV 07 M6	VCP 03	VRT 10 M4,5x12	T15
STIR/L S40U 22	40	37	300	25,6	16	IR/L.22	VRT 07 M4,5x11	VRIR 22	VAV 07 M6	VCP 03	VRT 10 M4,5x12	T15
STIR/L S50V 22	50	47	350	30,6	58	IR/L.22	VRT 07 M4,5x11	VRIR 22	VAV 07 M6	VCP 03	VRT 10 M4,5x12	T15



The red power for
Profesyoneller için
Kırmızı Güç

VORGEN®
G1011 2020R 3C GX24

VORGEN®
BKTR R390 2525 2C
(R390 HRN 1.9.2.9)

VORGEN®
BKTR R390 2525 2C
(R390 HRN 1.9.2.9)

VORGEN®
BKTR 154.91

VORGEN®
BKTR JK 2525 4C

VORGEN®
PCHR 2020 K34

DIŞ ÇAP
KANAL AÇMA TAKIMLARI
External grooving toolholders

www.vorgen.com



TEKNİK ÇİZİM / TECHNICAL DRAWING

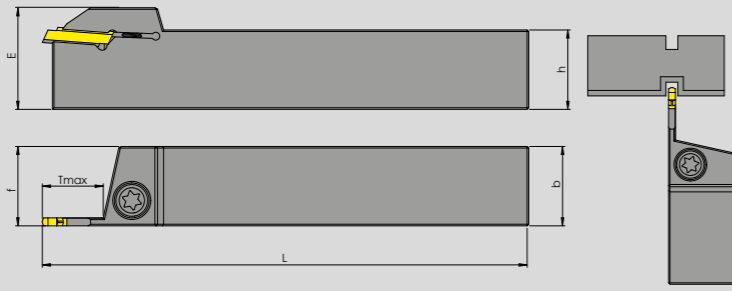

TEKNİK ÇİZİM / TECHNICAL DRAWING

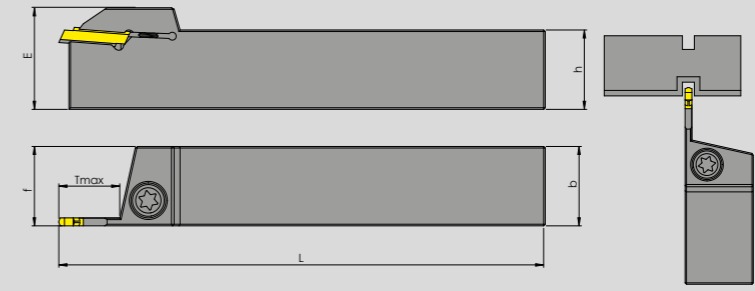

TAKIM KODU ORDERING CODE	KATER ÖLÇÜLERİ DIMENSIONS (mm)							KESİCİ UÇ INSERT	YEDEK PARÇALAR / SPARE PARTS	
	h	b	L	f	E	A	Tmax		BASKI VIDASI SPRING	TORX ANAHTAR ALLEN KEY
BKTR/L KH 1212 2C	12	12	100	12,3	24	1,8	15	S224.2	VRV 02 M6	AA3
BKTR/L KH 1616 2C	16	16	125	16	30	1,8	15			
BKTR/L KH 2020 2C	20	20	125	20	30	1,8	15	S224.2	VRV 06 M8	AA4
BKTR/L KH 2525 2C	25	25	150	25	34	1,8	15			
BKTR/L KH 2020 3C	20	20	125	20	30	2,5	20	S224.3	VRV 06 M8	AA4
BKTR/L KH 2525 3C	25	25	150	25	34	3	22			
BKTR/L KH 2020 4C	20	20	125	20	30	3	22	S224.4	VRV 06 M8	AA4
BKTR/L KH 2525 4C	25	25	150	25	34	4	22			
BKTR/L KH 2020 5C	20	20	125	20	30	4,2	22	S224.5	VRV 06 M8	AA4
BKTR/L KH 2525 5C	25	25	150	25	34	2,5	22			

TAKIM KODU ORDERING CODE	KATER ÖLÇÜLERİ DIMENSIONS (mm)							KESİCİ UÇ INSERT	YEDEK PARÇALAR / SPARE PARTS	
	h	b	L	f	E	A	Tmax		BASKI VIDASI SPRING	TORX ANAHTAR ALLEN KEY
BKTR/L BH 2020 3C	20	20	125	20	30	2,5	20	S229.3	VRV 06 M8	AA4
BKTR/L BH 2525 3C	32	32	150	32	34	2,5	22			
BKTR/L BH 3232 3C	32	32	170	32	42	2,5	22	S229.4	VRV 06 M8	AA4
BKTR/L BH 2020 4C	20	20	150	20	30	2,5	32			
BKTR/L BH 2525 4C	25	25	150	25	34	3,5	32	S229.4	VRV 06 M8	AA4
BKTR/L BH 3232 4C	32	32	170	32	42	3,5	22			
BKTR/L BH 2525 5C	25	25	150	25	34	4,5	33	S229.5	VRV 06 M8	AA4
BKTR/L BH 3232 5C	32	32	170	32	42	4,5	22			

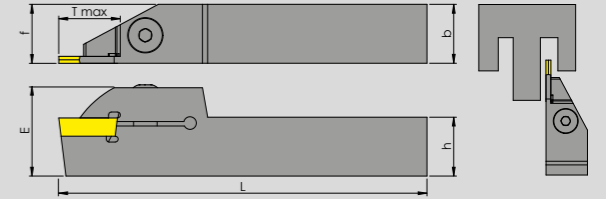

TEKNİK ÇİZİM / TECHNICAL DRAWING

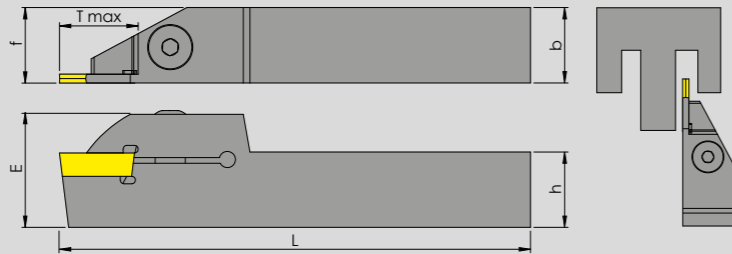

TAKIM KODU ORDERING CODE	KATER ÖLÇÜLERİ DIMENSIONS (mm)								KESİCİ UÇ INSERT	YEDEK PARÇALAR / SPARE PARTS	
	h	b	L	f	E	A	Tmax	BASKI VIDASI SPRING		TORX ANAHTAR ALLEN KEY	
BKTR/L IS 1212 2C	12	12	100	12	24	1,8	15	DGN.2	VRV 02 M6	AA3	
BKTR/L IS 1616 2C	16	16	125	16	30	1,8	15	DGN.2	VRV 06 M8	AA4	
BKTR/L IS 2020 2C	20	20	125	20	30	1,8	17				
BKTR/L IS 2525 2C	25	25	150	25	34	1,8	17				
BKTR/L IS 1212 3C	12	12	100	12	24	2,5	17	DGN.3	VRV 02 M6	AA3	
BKTR/L IS 1616 3C	16	16	125	16	30	2,5	15	DGN.3	VRV 06 M8	AA4	
BKTR/L IS 2020 3C	20	20	125	20	30	2,5	20				
BKTR/L IS 2525 3C	25	25	150	25	34	2,5	22				
BKTR/L IS 2020 4C	20	20	125	20	30	3	20	DGN.4	VRV 06 M8	AA4	
BKTR/L IS 2525 4C	25	25	150	25	34	3	22	DGN.5	VRV 06 M8	AA4	
BKTR/L IS 2525 5C	25	25	150	25	34	4,2	25				

TAKIM KODU ORDERING CODE	KATER ÖLÇÜLERİ DIMENSIONS (mm)								KESİCİ UÇ INSERT	YEDEK PARÇALAR / SPARE PARTS	
	h	b	L	f	E	A	Tmax	BASKI VIDASI SPRING		TORX ANAHTAR ALLEN KEY	
BKTR/L JK 1212 2C	12	12	100	12	24	1,8	15	MGM.2	VRV 02 M6	AA3	
BKTR/L JK 1616 2C	16	16	125	16	30	1,8	15	MGM.2	VRV 06 M8	AA4	
BKTR/L JK 2020 2C	20	20	125	20	30	1,8	15				
BKTR/L JK 2525 2C	25	25	150	25	34	1,8	15				
BKTR/L JK 3232 2C	32	32	170	32	42	1,8	15	MGM.3	VRV 02 M6	AA3	
BKTR/L JK 1212 3C	12	12	100	12	24	18	15				
BKTR/L JK 1616 3C	16	16	125	16	30	2,5	15				
BKTR/L JK 2020 3C	20	20	125	20	30	2,5	20	MGM.3	VRV 06 M8	AA4	
BKTR/L JK 2525 3C	25	25	150	25	34	2,5	22				
BKTR/L JK 3232 3C	32	32	170	32	42	2,5	22				
BKTR/L JK 2020 4C	20	20	125	20	30	3	22	MGM.4	VRV 06 M8	AA4	
BKTR/L JK 2525 4C	25	25	150	25	34	3	22				
BKTR/L JK 3232 4C	32	32	170	32	42	3	22				
BKTR/L JK 2020 5C	20	20	125	20	30	4,2	20	MGM.5	VRV 06 M8	AA4	
BKTR/L JK 2525 5C	25	25	150	25	34	4,2	25				
BKTR/L JK 3232 5C	32	32	170	32	42	4,2	25				
BKTR/L JK 2525 6C	25	25	150	25	34	5	25	MGM.6	VRV 06 M8	AA4	
BKTR/L JK 3232 6C	32	32	170	32	42	5	25				
BKTR/L JK 3232 8C	32	32	170	32	42	7	28				



TEKNİK ÇİZİM / TECHNICAL DRAWING

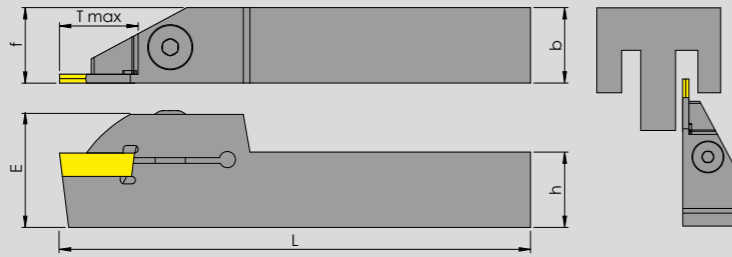

TEKNİK ÇİZİM / TECHNICAL DRAWING

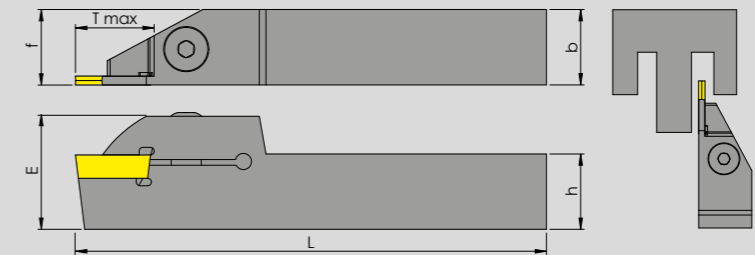

TAKIM KODU ORDERING CODE	KATER ÖLÇÜLERİ DIMENSIONS (mm)								KESİCİ UÇ INSERT	YEDEK PARÇALAR / SPARE PARTS	
	h	b	L	f	E	A	Tmax	BASKI VIDASI SPRING		TORX ANAHTAR ALLEN KEY	
BKTR/L TDC 1616 2C	16	16	125	16	30	1,8	15	TDC.2	VRV 06 M8	AA4	
BKTR/L TDC 2020 2C	20	20	125	20	30	1,8	15				
BKTR/L TDC 2525 2C	25	25	150	25	34	2,5	17	TDC.3	VRV 06 M8	AA4	
BKTR/L TDC 1616 3C	16	16	125	16	30	2,5	15				
BKTR/L TDC 2020 3C	20	20	125	20	30	2,5	20	TDC.4	VRV 06 M8	AA4	
BKTR/L TDC 2525 3C	25	25	150	25	34	2,5	22				
BKTR/L TDC 2020 4C	20	20	125	20	30	3	20	TDC.4	VRV 06 M8	AA4	
BKTR/L TDC 2525 4C	25	25	150	25	34	3	22				

TAKIM KODU ORDERING CODE	KATER ÖLÇÜLERİ DIMENSIONS (mm)								KESİCİ UÇ INSERT	YEDEK PARÇALAR / SPARE PARTS	
	h	b	L	f	E	A	Tmax	BASKI VIDASI SPRING		TORX ANAHTAR ALLEN KEY	
BKTR/L ZCC2 2020 2C	20	20	125	20	30	1,6	15	ZT.D2	VRV 06 M8	AA4	
BKTR/L ZCC2 2525 2C	25	25	150	25	34	1,6	15				
BKTR/L ZCC2 2020 3C	20	20	125	20	30	2,5	20	ZT.D3	VRV 06 M8	AA4	
BKTR/L ZCC2 2525 3C	25	25	150	25	34	2,5	22				
BKTR/L ZCC2 2020 4C	20	20	125	20	30	3	20	ZT.D4	VRV 06 M8	AA4	
BKTR/L ZCC2 2525 4C	25	25	150	25	34	3	22				
BKTR/L ZCC2 2020 5C	20	20	125	20	30	4	20	ZT.D5	VRV 06 M8	AA4	
BKTR/L ZCC2 2525 5C	25	25	150	25	34	4	25				
BKTR/L ZCC2 2525 6C	25	25	150	25	34	5,5	25	ZT.D6	VRV 06 M8	AA4	



TEKNİK ÇİZİM / TECHNICAL DRAWING

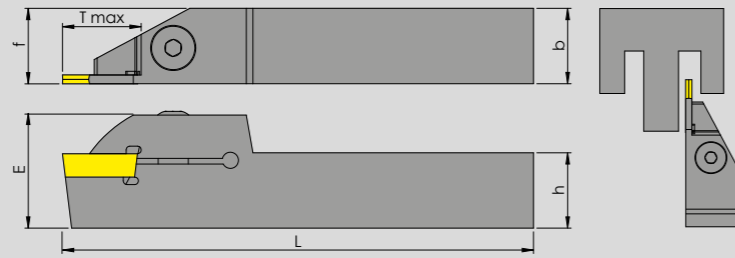

TAKIM KODU ORDERING CODE	KATER ÖLÇÜLERİ DIMENSIONS (mm)							KESİCİ UÇ INSERT	YEDEK PARÇALAR / SPARE PARTS	
	h	b	L	f	E	A	Tmax		BASKI VIDASI SPRING	TORX ANAHTAR ALLEN KEY
BKTR/L S123 1212 2C	12	12	100	12	24	1,8	15	S123.2	VRV 02 M6	AA3
BKTR/L S123 1616 2C	16	16	125	16	30	1,8	15			
BKTR/L S123 2020 2C	20	20	125	20	30	1,8	15			
BKTR/L S123 2525 2C	25	25	150	25	34	1,8	15	S123.3	VRV 02 M6	AA3
BKTR/L S123 1212 3C	12	12	100	12	24	2,5	20			
BKTR/L S123 1616 3C	16	16	125	16	30	2,5	20			
BKTR/L S123 2020 3C	20	20	125	20	30	2,5	20	S123.3	VAV 06 M8	AA4
BKTR/L S123 2525 3C	25	25	150	25	34	2,5	20			
BKTR/L S123 2020 4C	20	20	125	20	30	3	22			
BKTR/L S123 2525 4C	25	25	150	25	34	3	22	S123.4	VRV 06 M8	AA4
BKTR/L S123 2525 5C	25	25	150	25	34	4,2	25			
BKTR/L S123 2525 5C	25	25	150	25	34	4,2	25	S123.5	VRV 06 M8	AA4



TEKNİK ÇİZİM / TECHNICAL DRAWING

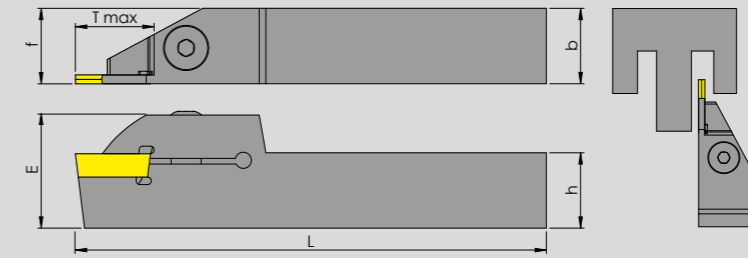

TAKIM KODU ORDERING CODE	KATER ÖLÇÜLERİ DIMENSIONS (mm)							KESİCİ UÇ INSERT	YEDEK PARÇALAR / SPARE PARTS	
	h	b	L	f	E	A	Tmax		BASKI VIDASI SPRING	TORX ANAHTAR ALLEN KEY
BKTR/L DGM 1616 2C	16	16	125	16	30	1,8	15	DGM.2	VRV 06 M8	AA4
BKTR/L DGM 2020 2C	20	20	125	20	30	1,8	15			
BKTR/L DGM 2525 2C	25	25	150	25	34	2,5	17			
BKTR/L DGM 1616 3C	16	16	125	16	30	2,5	15	DGM.3	VRV 06 M8	AA4
BKTR/L DGM 2020 3C	20	20	125	20	30	2,5	20			
BKTR/L DGM 2525 3C	25	25	150	25	34	2,5	22			
BKTR/L DGM 2020 4C	20	20	125	20	30	3	20	DGM.4	VRV 06 M8	AA4
BKTR/L DGM 2525 4C	25	25	150	25	34	3	22			



TEKNİK ÇİZİM / TECHNICAL DRAWING

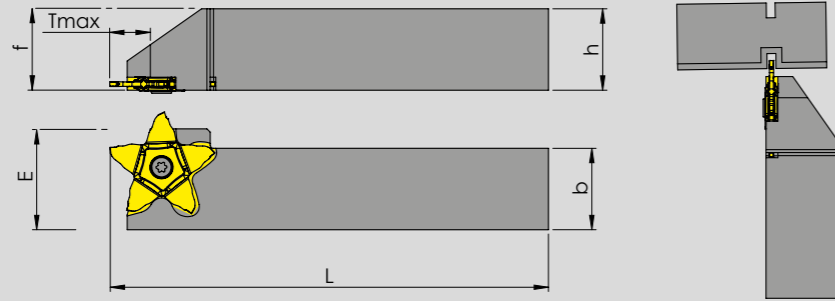

TAKIM KODU ORDERING CODE				KATER ÖLÇÜLERİ DIMENSIONS (mm)						KESİCİ UÇ INSERT	YEDEK PARÇALAR / SPARE PARTS	
				h	b	L	f	E	Tmax		BASKI VIDASI SPRING	TORX ANAHTAR TORX KEY
PCHR/L	PNT	1616	H24	16	16	100	16	30	6,5	PNT.24	VRT 11 M5	T20
PCHR/L	PNT	2020	K24	20	20	125	20	30	6,5			
PCHR/L	PNT	2525	M24	25	25	150	25	34	6,5			
PCHR/L	PNT	2020	K34	20	20	125	20	30	10	PNT.34	VRT 11 M5	T20
PCHR/L	PNT	2525	M34	25	25	150	25	34	10			



TEKNİK ÇİZİM / TECHNICAL DRAWING

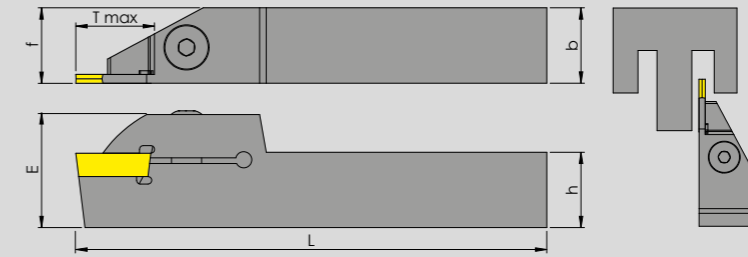

TAKIM KODU ORDERING CODE				KATER ÖLÇÜLERİ DIMENSIONS (mm)						KESİCİ UÇ INSERT	YEDEK PARÇALAR / SPARE PARTS		
				h	b	L	f	E	A		Tmax	BASKI VIDASI SPRING	TORX ANAHTAR ALLEN KEY
BKTR/L	GX24	1616	2C	16	16	125	16	30	1,8	15	GX24.2	VRV 06 M8	AA4
BKTR/L	GX24	2020	2C	20	20	125	20	30	1,8	15			
BKTR/L	GX24	2525	2C	25	25	150	25	34	2,5	17			
BKTR/L	GX24	1616	3C	16	16	125	16	30	2,5	15	GX24.3	VRV 06 M8	AA4
BKTR/L	GX24	2020	3C	20	20	125	20	30	2,5	20			
BKTR/L	GX24	2525	3C	25	25	150	25	34	2,5	22			
BKTR/L	GX24	2020	4C	20	20	125	20	30	3	20	GX24.4	VRV 06 M8	AA4
BKTR/L	GX24	2525	4C	25	25	150	25	34	3	22			



TEKNİK ÇİZİM / TECHNICAL DRAWING

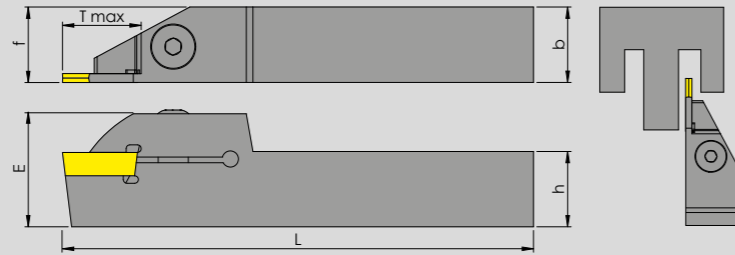

TAKIM KODU ORDERING CODE				KATER ÖLÇÜLERİ DIMENSIONS (mm)						KESİCİ UÇ INSERT	YEDEK PARÇALAR / SPARE PARTS		
											BASKI VIDASI SPRING	TORX ANAHTAR ALLEN KEY	
BKTR/L	GDM	1616	2C	16	16	125	16	30	1,8	15	GDM.2	VRV 06 M8	AA4
BKTR/L	GDM	2020	2C	20	20	125	20	30	1,8	15			
BKTR/L	GDM	2525	2C	25	25	150	25	34	2,5	17			
BKTR/L	GDM	1616	3C	16	16	125	16	30	2,5	15			
BKTR/L	GDM	2020	3C	20	20	125	20	30	2,5	20	GDM.3	VRV 06 M8	AA4
BKTR/L	GDM	2525	3C	25	25	150	25	34	2,5	22			
BKTR/L	GDM	2020	4C	20	20	125	20	30	3	20	GDM.4	VRV 06 M8	AA4
BKTR/L	GDM	2525	4C	25	25	150	25	34	3	22			



TEKNİK ÇİZİM / TECHNICAL DRAWING

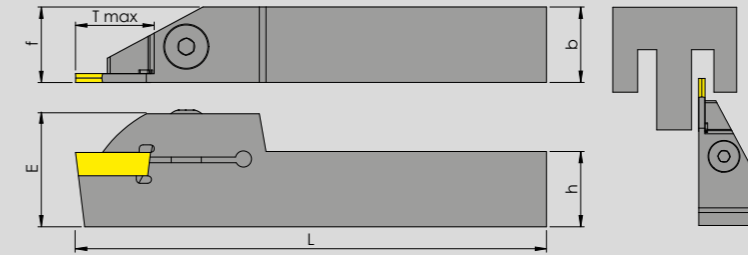

TAKIM KODU ORDERING CODE				KATER ÖLÇÜLERİ DIMENSIONS (mm)						KESİCİ UÇ INSERT	YEDEK PARÇALAR / SPARE PARTS		
											BASKI VIDASI SPRING	TORX ANAHTAR ALLEN KEY	
BKTR/L	KGM	1616	2C	16	16	125	16	30	1,8	15	KGMN.2	VRV 06 M8	AA4
BKTR/L	KGM	2020	2C	20	20	125	20	30	1,8	15			
BKTR/L	KGM	2525	2C	25	25	150	25	34	2,5	17			
BKTR/L	KGM	1616	3C	16	16	125	16	30	2,5	15			
BKTR/L	KGM	2020	3C	20	20	125	20	30	2,5	20	KGMN.3	VRV 06 M8	AA4
BKTR/L	KGM	2525	3C	25	25	150	25	34	2,5	22			
BKTR/L	KGM	2020	4C	20	20	125	20	30	3	20	KGMN.4	VRV 06 M8	AA4
BKTR/L	KGM	2525	4C	25	25	150	25	34	3	22			



TEKNİK ÇİZİM / TECHNICAL DRAWING

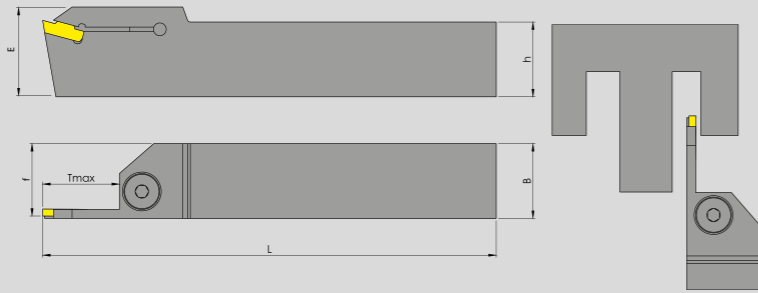

TAKIM KODU ORDERING CODE				KATER ÖLÇÜLERİ DIMENSIONS (mm)							KESİCİ UÇ INSERT	YEDEK PARÇALAR / SPARE PARTS		
BKTR	LCM	2020	3C	h	b	L	f	E	A	Tmax	LCMF3	BASKI VİDASI SPRING	TORX ANAHTAR ALLEN KEY	
												VRV 06 M8	AA4	
BKTR	LCM	2020	3C	20	20	125	20	28	2,5	20	LCMF3	VRV 06 M8	AA4	
BKTR	LCM	2525	3C	25	25	150	25	33	2,5	20	LCMF3	VRV 06 M8	AA4	

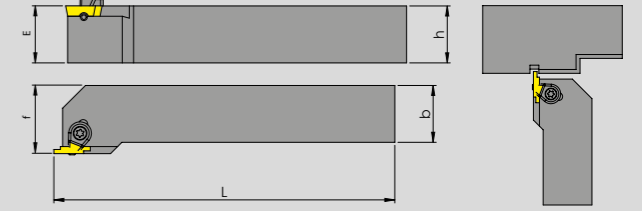

TAKIM KODU ORDERING CODE				KATER ÖLÇÜLERİ DIMENSIONS (mm)							KESİCİ UÇ INSERT	YEDEK PARÇALAR / SPARE PARTS		
BKTR/L	154.91	2020	3Q	h	b	L	f	E	A	Tmax	154.91-3	BASKI PARÇASI WEDGE CLAMP	BASKI VİDASI SCREW	TORX ANAHTAR TORX KEY
												VCP 03	VRT 09 M4x11	T15
BKTR/L	154.91	2020	3Q	20	20	125	20	25	2,5	4	154.91-3	VCP 03	VRT 09 M4x11	T15
BKTR/L	154.91	2525	3Q	25	25	150	25	25	2,5	4	154.91-3	VCP 03	VRT 09 M4x11	T15

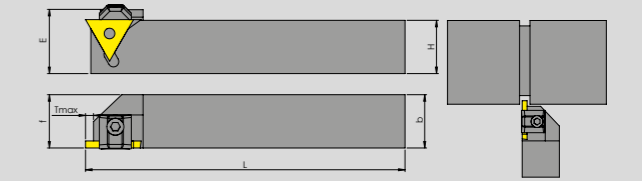

TAKIM KODU ORDERING CODE				KATER ÖLÇÜLERİ DIMENSIONS (mm)							KESİCİ UÇ INSERT	YEDEK PARÇALAR / SPARE PARTS		
BKTR/L	R390	2525	2C (1.9 2.9)	h	b	L	f	E	A	Tmax	R390 HRN	BASKI PARÇASI WEDGE CLAMP	BASKI VİDASI SPRING	TORX ANAHTAR ALLEN KEY
												VKP 01	VRV 09 M6	AA4
BKTR/L	R390	2525	2C (1.9 2.9)	25	25	150	25	25	1,8	6	R390 HRN	VKP 01	VRV 09 M6	AA4
BKTR/L	R390	2525	3C (2.9 3.9)	25	25	150	25	25	3	6	R390 HRN	VKP 01	VRV 09 M6	AA4
BKTR/L	R390	2525	4C (3.9 4.9)	25	25	150	25	25	4	6	R390 HRN	VKP 01	VRV 09 M6	AA4

PASO

ÜRÜN / PRODUCT



TEKNİK ÇİZİM / TECHNICAL DRAWING

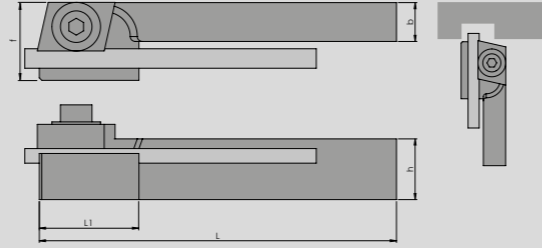

TAKIM KODU ORDERING CODE		KATER ÖLÇÜLERİ DIMENSIONS (mm)					KESİCİ UÇ INSERT	YEDEK PARÇALAR / SPARE PARTS		
		f	h	b	L	L1		BASKI PARÇASI WEDGE CLAMP	BASKI VIDASI SCREW	ANAHTAR ALLEN KEY
PASO	6x8	32	25	16	150	50	6x6-8x8	BPV M8	VRV8 M8x25	AA6
PASO	8x10	34	25	16	150	50				
PASO	10x12	36	25	16	150	50				
PASO	12x14	38	25	16	150	50				

KESME

ÜRÜN / PRODUCT



TEKNİK ÇİZİM / TECHNICAL DRAWING

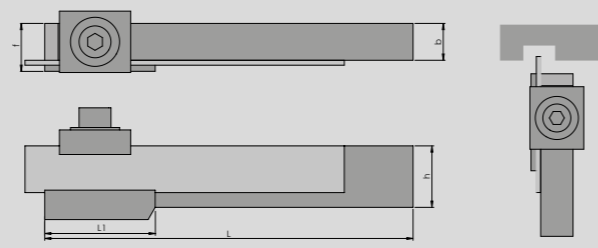

TAKIM KODU ORDERING CODE		KATER ÖLÇÜLERİ DIMENSIONS (mm)					KESİCİ UÇ INSERT	YEDEK PARÇALAR / SPARE PARTS		
		f	h	b	L	L1		BASKI PARÇASI WEDGE CLAMP	BASKI VIDASI SCREW	ANAHTAR ALLEN KEY
KESME	1/2	24	25	16	130	50	12,7x3-4	BBV M8	VRV8 M8x25	AA6
KESME	5/8	24	25	16	130	50				
KESME	3/4	30	25	16	150	50				
KESME	7/8	35	25	16	150	50				
KESME	1	35	25	16	150	50				



DIŞ ÇAP ALIN KANAL
AÇMA TAKIMLARI

Face external
grooving toolholders

www.vorgen.com

The red power for
the professionals
Profesyoneller için
Kırmızı Güç

BKATR/L JK ÜRÜN / PRODUCT

TEKNİK ÇİZİM / TECHNICAL DRAWING

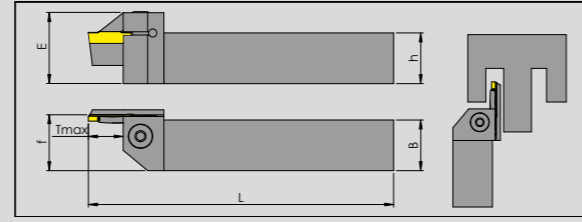

TAKIM KODU ORDERING CODE	KATER ÖLÇÜLERİ DIMENSIONS (mm)										KESİCİ UÇ INSERT	YEDEK PARÇALAR / SPARE PARTS	
	h	b	L	f	E	A	Tmax	Dmin	Dmax	BASKI VIDASI SCREW		TORX ANAHTAR ALLEN KEY	
BKATR/L-JK 2525 (34-45) 3C	25	25	150	26,5	34	2,2	18	34	45	MGM.3	VRV 06 M8	AA4	
BKATR/L-JK 2525 (39-55) 3C	25	25	150	26,5	34	2,2	18	39	55				
BKATR/L-JK 2525 (49-80) 3C	25	25	150	26,5	34	2,2	18	49	80				
BKATR/L-JK 2525 (70-110) 3C	25	25	150	26,5	34	2,2	18	70	110				
BKATR/L-JK 2525 (100-150) 3C	25	25	150	26,5	34	2,2	18	100	150				



BKLTR/L JK ÜRÜN / PRODUCT

TEKNİK ÇİZİM / TECHNICAL DRAWING

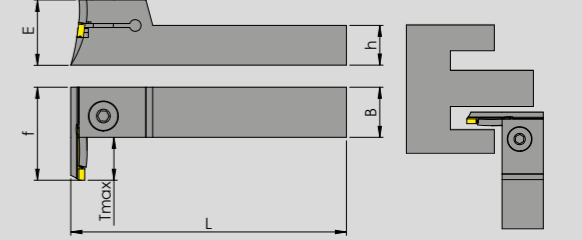

TAKIM KODU ORDERING CODE	KATER ÖLÇÜLERİ DIMENSIONS (mm)										KESİCİ UÇ INSERT	YEDEK PARÇALAR / SPARE PARTS	
	h	b	L	f	E	A	Tmax	Dmin	Dmax	BASKI VIDASI SCREW		TORX ANAHTAR ALLEN KEY	
BKLTR/L-JK 2525 (25-35) 3C	25	25	150	37	34	2,2	12	25	35	MGM.3	VRV 06 M8	AA4	
BKLTR/L-JK 2525 (35-55) 3C	25	25	150	37	34	2,2	12	35	55				
BKLTR/L-JK 2525 (50-75) 3C	25	25	150	37	34	2,2	12	50	75				
BKLTR/L-JK 2525 (70-105) 4C	25	25	150	37	34	3,2	14	70	105				
BKLTR/L-JK 2525 (100-205) 4C	25	25	150	37	34	3,2	14	100	205	MGM.4			

BKLTR/L GX24 ÜRÜN / PRODUCT

TEKNİK ÇİZİM / TECHNICAL DRAWING

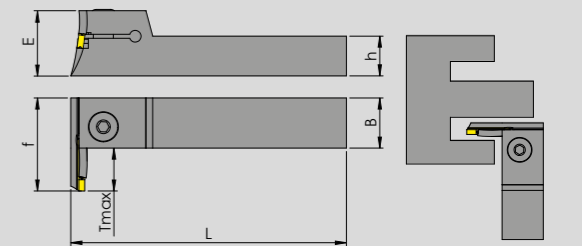

TAKIM KODU ORDERING CODE	KATER ÖLÇÜLERİ DIMENSIONS (mm)										KESİCİ UÇ INSERT	YEDEK PARÇALAR / SPARE PARTS	
	h	b	L	f	E	A	Tmax	Dmin	Dmax	BASKI VIDASI SCREW		TORX ANAHTAR ALLEN KEY	
BKLTR/L-GX24 2525 (25-35) 3C	25	25	150	37	34	2,2	12	25	35	GX24.3	VRV 06 M8	AA4	
BKLTR/L-GX24 2525 (35-55) 3C	25	25	150	37	34	2,2	12	35	55				
BKLTR/L-GX24 2525 (50-75) 3C	25	25	150	37	34	2,2	12	50	75				
BKLTR/L-GX24 2525 (70-105) 4C	25	25	150	37	34	3,2	14	70	105				
BKLTR/L-GX24 2525 (100-205) 4C	25	25	150	37	34	3,2	14	100	205	GX24.4			

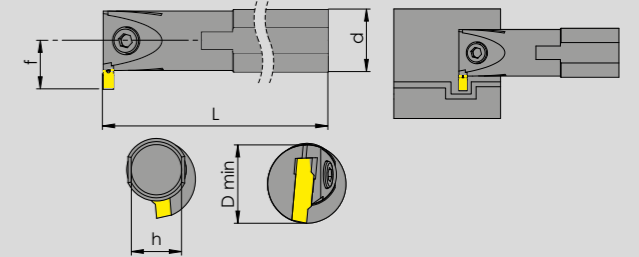
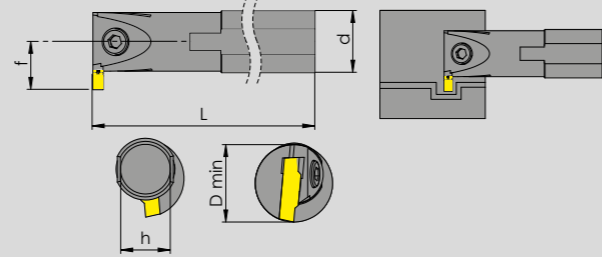

TAKIM KODU ORDERING CODE				KATER ÖLÇÜLERİ DIMENSIONS (mm)					KESİCİ UÇ INSERT	YEDEK PARÇALAR / SPARE PARTS	
										BASKI VIDASI SCREW	TORX ANAHTAR ALLEN KEY
BKTI-R/L	KH	S16Q	2C	180	16	11	14	S224.2	VRV 07 M5	AA4	
BKTI-R/L	KH	S20R	2C	190	20	13	18				
BKTI-R/L	KH	S25R	2C	200	25	17	23	S224.3	VRV 08 M5	AA4	
BKTI-R/L	KH	S20R	3C	190	20	13	18				
BKTI-R/L	KH	S25R	3C	200	25	17	23	S224.4	VRV 08 M5	AA4	
BKTI-R/L	KH	S20R	4C	190	20	13	18				
BKTI-R/L	KH	S25R	4C	200	25	17	23	S224.5	VRV 08 M5	AA4	
BKTI-R/L	KH	S25R	5C	200	25	17	23				

TAKIM KODU ORDERING CODE				KATER ÖLÇÜLERİ DIMENSIONS (mm)					KESİCİ UÇ INSERT	YEDEK PARÇALAR / SPARE PARTS	
										BASKI VIDASI SCREW	TORX ANAHTAR ALLEN KEY
BKTI-R/L	JK	S16Q	2C	180	16	11	14	MGM.2	VRV 07 M5	AA4	
BKTI-R/L	JK	S20R	2C	190	20	13	18				
BKTI-R/L	JK	S25R	2C	200	25	17	23	MGM.3	VRV 07 M5	AA4	
BKTI-R/L	JK	S32T	2C	300	32	17	30				
BKTI-R/L	JK	S20R	3C	190	20	13	18	MGM.4	VRV 07 M5	AA4	
BKTI-R/L	JK	S25R	3C	200	25	17	23				
BKTI-R/L	JK	S32T	3C	300	32	17	30	MGM.5	VRV 07 M5	AA4	
BKTI-R/L	JK	S20R	4C	190	20	13	18				
BKTI-R/L	JK	S25R	4C	200	25	17	23	MGM.5	VRV 06 M8	AA4	
BKTI-R/L	JK	S32T	4C	300	32	17	30				
BKTI-R/L	JK	S25R	5C	200	25	17	23	MGM.5	VRV 06 M8	AA4	
BKTI-R/L	JK	S32T	5C	300	32	17	30				

BKTI-R S123 ÜRÜN / PRODUCT

TEKNİK ÇİZİM / TECHNICAL DRAWING

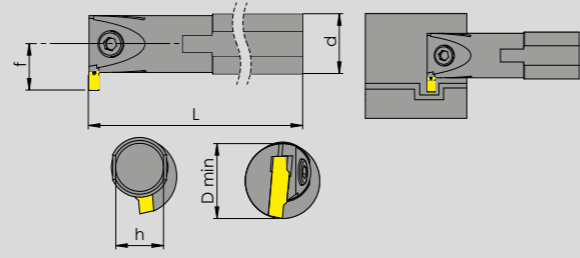

TAKIM KODU ORDERING CODE	KATER ÖLÇÜLERİ DIMENSIONS (mm)					KESİCİ UÇ INSERT	YEDEK PARÇALAR / SPARE PARTS	
	L	d	f	h	Tmax		BASKI VIDASI SCREW	TORX ANAHTAR ALLEN KEY
BKTI-R/L S123 S16Q 2C	180	16	11	14	4	S123.2	VRV 07 M5	AA4
BKTI-R/L S123 S20R 2C	190	20	13	18				
BKTI-R/L S123 S25R 2C	200	25	17	23				
BKTI-R/L S123 S32T 2C	300	32	17	30				
BKTI-R/L S123 S20R 3C	190	20	13	18	5	S123.3	VRV 07 M5	AA4
BKTI-R/L S123 S25R 3C	200	25	17	23				
BKTI-R/L S123 S32T 3C	300	32	17	30				
BKTI-R/L S123 S20R 4C	190	20	13	18	7	S123.4	VRV 07 M5	AA4
BKTI-R/L S123 S25R 5C	200	25	17	23				
BKTI-R/L S123 S32T 5C	300	32	17	30	8	S123.5	VRV 06 M8	AA4

BKTI-R 154.91 ÜRÜN / PRODUCT

TEKNİK ÇİZİM / TECHNICAL DRAWING

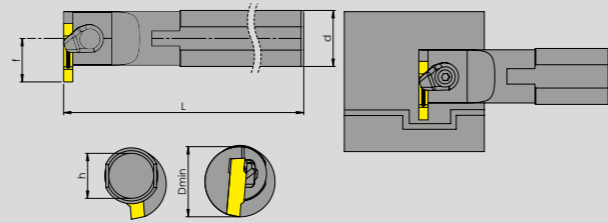

TAKIM KODU ORDERING CODE	KATER ÖLÇÜLERİ DIMENSIONS (mm)					KESİCİ UÇ INSERT	YEDEK PARÇALAR / SPARE PARTS		
	L	d	f	h	Tmax		BASKI PARÇASI WEDGE CLAMP	BASKI VIDASI SCREW	ANAHTAR TORX KEY
BKTI-R/L 154.91 S16Q 3Q	180	16	11	14	4	154.91.3	VCP 03	VRT 09 M4x11	T15
BKTI-R/L 154.91 S20R 3Q	190	20	13	18					
BKTI-R/L 154.91 S25R 3Q	200	25	17	23					

BKTI-R IS ÜRÜN / PRODUCT

TEKNİK ÇİZİM / TECHNICAL DRAWING

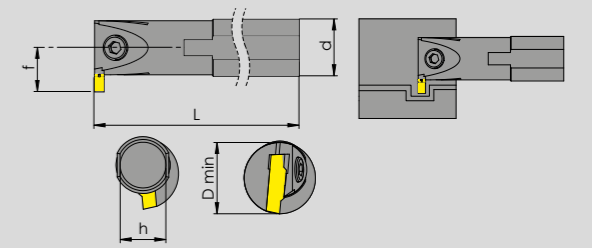

TAKIM KODU ORDERING CODE	KATER ÖLÇÜLERİ DIMENSIONS (mm)					KESİCİ UÇ INSERT	YEDEK PARÇALAR / SPARE PARTS	
	L	d	f	h	Tmax		BASKI VIDASI SCREW	TORX ANAHTAR ALLEN KEY
BKTI-R/L IS S20R 2C	190	20	13	18	5	DGN 2	VRV 07 M5	AA4
BKTI-R/L IS S25R 2C	200	25	17	23				
BKTI-R/L IS S20R 3C	190	20	13	18	6	DGN 3	VRV 07 M5	AA4
BKTI-R/L IS S25R 3C	200	25	17	23				

BKTI-R/BH ÜRÜN / PRODUCT

TEKNİK ÇİZİM / TECHNICAL DRAWING

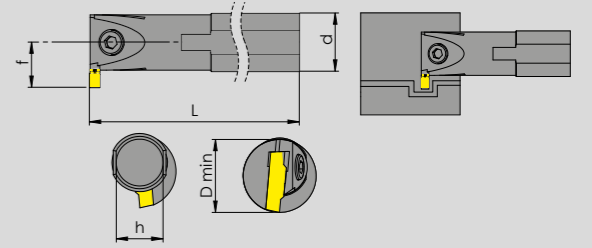

TAKIM KODU ORDERING CODE	KATER ÖLÇÜLERİ DIMENSIONS (mm)					KESİCİ UÇ INSERT	YEDEK PARÇALAR / SPARE PARTS	
	L	d	f	h	Tmax		BASKI VIDASI SCREW	TORX ANAHTAR ALLEN KEY
BKTI-R/L BH S25R 3C	200	25	17	23	7	S229-3	VRV 07 M5	AA4
BKTI-R/L BH S32T 3C	300	32	22	32				
BKTI-R/L BH S40V 3C	300	40	26,5	37,5				
BKTI-R/L BH S25R 4C	200	25	17	23	7	S229-4	VRV 07 M5	AA4
BKTI-R/L BH S32T 4C	300	32	22	32				
BKTI-R/L BH S40V 4C	300	40	26,5	37,5				
BKTI-R/L BH S25R 5C	200	25	17	23	7	S229-5	VRV 07 M5	AA4
BKTI-R/L BH S32T 5C	300	32	22	32				
BKTI-R/L BH S40V 5C	300	40	26,5	37,5				

SPTC 16 ÜRÜN / PRODUCT 45°

TEKNİK ÇİZİM / TECHNICAL DRAWING

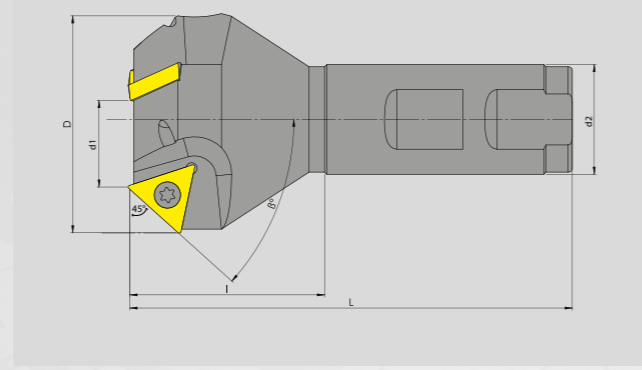

TAKIM KODU ORDERING CODE	KATER ÖLÇÜLERİ DIMENSIONS (mm)				KESİCİ UÇ INSERT	YEDEK PARÇALAR / SPARE PARTS				
	D	d1	d2	L		KESİCİ UÇ INSERT	BASKI VIDASI SCREW	ANAHTAR TORX KEY		
SPTC11	4-15x1	16-100	15	4	16	100	1	TC.. 1102	VRT03 M2,5x5	T08
SPTC16	4-23x1	16-100	23	4	16	100	1			
SPTC16	10-31x2	16-100	31	10	16	100	1			
SPTC16	14-35x2	20-100	35	14	20	100	2	TC.. 16T3	VRT06 M3,5x9	T15
SPTC16	22-43x3	25-100	43	22	25	100	3			
SPTC16	32-53x3	25-100	53	32	25	100	3			

SPSC 09 ÜRÜN / PRODUCT 45°

TEKNİK ÇİZİM / TECHNICAL DRAWING

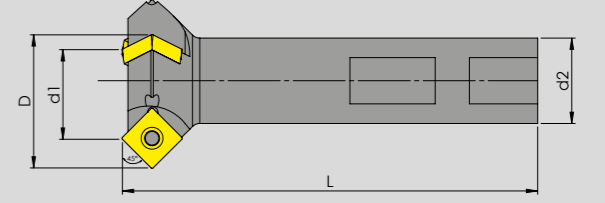

TAKIM KODU ORDERING CODE	KATER ÖLÇÜLERİ DIMENSIONS (mm)				KESİCİ UÇ INSERT	YEDEK PARÇALAR / SPARE PARTS				
	D	d1	d2	L		KESİCİ UÇ INSERT	BASKI VIDASI SCREW	ANAHTAR TORX KEY		
SPSC09	4-13x1	16 120	13	4	16	120	1			
SPSC09	19-31x3	20 120	31	19	20	120	3	SC.. 09 T3	VRT 07 M3,5x11	T15
SPSC09	20-41x3	25 120	41	20	25	120	3			
SPSC12	35-50x4	25 120	50	35	25	120	4	SC.. 1204	VRT 10 M4,5	T20

SPSP09 ÜRÜN / PRODUCT 45°

TEKNİK ÇİZİM / TECHNICAL DRAWING

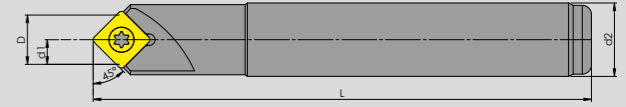

TAKIM KODU ORDERING CODE	KATER ÖLÇÜLERİ DIMENSIONS (mm)				KESİCİ UÇ INSERT	YEDEK PARÇALAR / SPARE PARTS				
	D	d1	d2	L		KESİCİ UÇ INSERT	BASKI VIDASI SCREW	ANAHTAR TORX KEY		
SPSP09	4-16x1	16 110	16	4	16	110	1	SP.. 09 03	VRT 07 M3,5x11	T15





The red power for
the professionals
Profesyoneller için
Kırmızı Güç



**FREZE
TAKIMLARI**
Milling tools

www.vorgen.com



TEKNİK ÇİZİM / TECHNICAL DRAWING

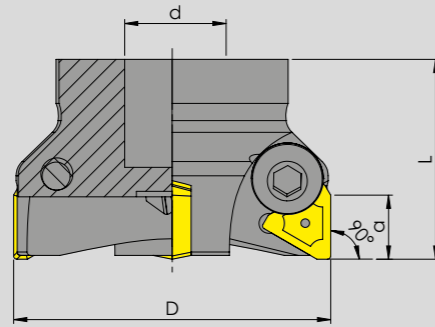

TAKIM KODU ORDERING CODE	TAKIM ÖLÇÜLERİ DIMENSIONS (mm)				KESİCİ UÇ ADET INSERT NUMBER	YEDEK PARÇALAR / SPARE PARTS				
	D	d	L	A		KESİCİ UÇ INSERT	BASKI VIDASI SCREW	ALTLIK SHIM	ALTLIK VIDASI SHIM SCREW	ANAHTAR ALLEN KEY
VRF90S TP22 D063 d22 Z03	63	22	40	20	3	TPKN 2204	VRV 002 M8	VRTN 22	VAV 02 M5	AA5
VRF90S TP22 D080 d27 Z04	80	27	50	20	4					
VRF90S TP22 D100 d32 Z05	100	32	50	20	5					
VRF90S TP22 D125 d40 Z06	125	40	62	20	6					
VRF90S TP22 D160 d40 Z07	160	40	62	20	7					
VRF90 TP22 D063 d22 Z03	63	22	40	20	3					
VRF90 TP22 D080 d27 Z04	80	27	50	20	4					
VRF90 TP22 D100 d32 Z05	100	32	50	20	5	TPKN 2204	VRV 002 M8		AA5	
VRF90 TP22 D125 d40 Z06	125	40	62	20	6					
VRF90 TP22 D160 d40 Z07	160	40	62	20	7					



TEKNİK ÇİZİM / TECHNICAL DRAWING

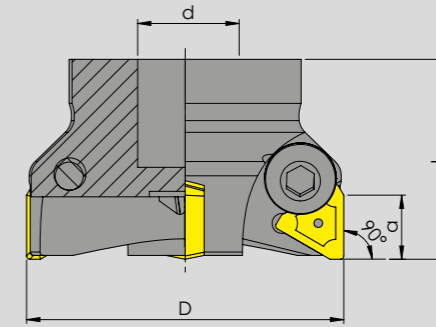

TAKIM KODU ORDERING CODE	TAKIM ÖLÇÜLERİ DIMENSIONS (mm)				KESİCİ UÇ ADET INSERT NUMBER	YEDEK PARÇALAR / SPARE PARTS				
	D	d	L	A		KESİCİ UÇ INSERT	BASKI VIDASI SCREW	ALTLIK SHIM	ALTLIK VIDASI SHIM SCREW	ANAHTAR ALLEN KEY
VRF90S TP16 D080 d27 Z05	80	27	50	20	5	TPKN 1603	VRV 001 M6	VRTN 16	VAV 02 M5	AA5
VRF90S TP16 D100 d32 Z06	100	32	50	20	6					
VRF90 TP16 D042 d16 Z03	42	16	45	14	3	TPKN 1603	VRV 001 M6			AA5
VRF90 TP16 D050 d22 Z03	50	22	45	14	3					
VRF90 TP16 D063 d22 Z03	63	22	45	14	3					
VRF90 TP16 D063 d22 Z04	63	22	45	14	4					
VRF90 TP16 D080 d27 Z05	80	27	50	14	5					
VRF90 TP16 D100 d32 Z06	100	32	50	14	6					



TEKNİK ÇİZİM / TECHNICAL DRAWING

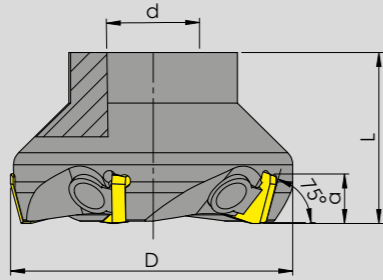

TEKNİK ÇİZİM / TECHNICAL DRAWING

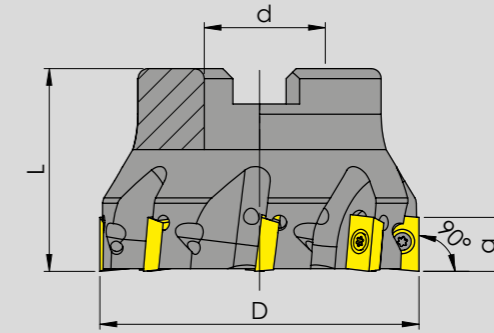

TAKIM KODU ORDERING CODE	TAKIM ÖLÇÜLERİ DIMENSIONS (mm)				KESİCİ UÇ ADET INSERT NUMBER	YEDEK PARÇALAR / SPARE PARTS				
	D	d	L	A		KESİCİ UÇ INSERT	BASKI VIDASI SCREW	BASKI PARÇASI WEDGE CLAMP	ALTLIK VIDASI SHIM SCREW	ANAHTAR ALLEN KEY
VRF75 SP12 D050 d22 Z04	50	22	40	5	4	SPKN 1204	VKP 002 M8	VRV 07 M6		AA4
VRF75 SP12 D063 d22 Z05	63	22	50	5	5					
VRF75 SP12 D080 d27 Z06	80	27	50	5	6					
VRF75 SP12 D100 d32 Z08	100	32	50	5	8					
VRF75 SP12 D125 d40 Z10	125	40	62	5	10					
VRF75 SP12 D160 d40 Z12	160	40	62	5	12					
VRF75 SP12 D200 d40 Z14	200	60	62	5	14					
VRF75 SP12 D300 d40 Z20	300	60	65	5	20					

TAKIM KODU ORDERING CODE	TAKIM ÖLÇÜLERİ DIMENSIONS (mm)				KESİCİ UÇ ADET INSERT NUMBER	YEDEK PARÇALAR / SPARE PARTS				
	D	d	L	A		KESİCİ UÇ INSERT	BASKI VIDASI SCREW	ALTLIK SHIM	ALTLIK VIDASI SHIM SCREW	ANAHTAR TORX KEY
VRF90 AP16 D040 d16 Z04	40	16	40	13	4	APKT 1604	VRT 09 M4x11			T15
VRF90 AP16 D050 d22 Z05	50	22	40	13	5					
VRF90 AP16 D063 d22 Z06	63	22	40	13	6					
VRF90 AP16 D080 d27 Z07	80	27	50	13	7					
VRF90 AP16 D100 d32 Z08	100	32	50	13	8					
VRF90 AP16 D125 d40 Z09	125	40	60	13	9					
VRF90 AP16 D160 d40 Z10	160	40	60	13	10					



TEKNİK ÇİZİM / TECHNICAL DRAWING

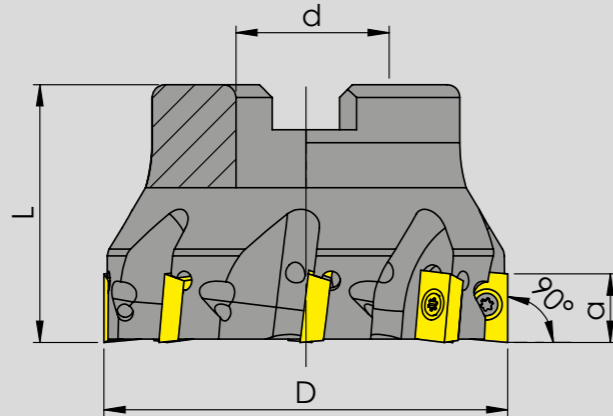

TEKNİK ÇİZİM / TECHNICAL DRAWING

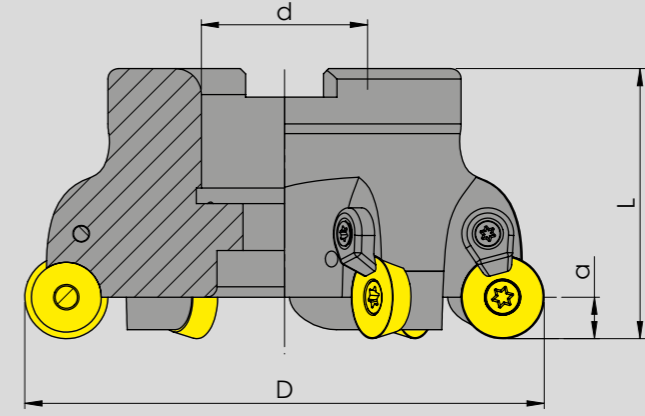

TAKIM KODU ORDERING CODE		TAKIM ÖLÇÜLERİ DIMENSIONS (mm)				KESİCİ UÇ ADET INSERT NUMBER	YEDEK PARÇALAR / SPARE PARTS					
							KESİCİ UÇ INSERT	BASKI VIDASI SCREW	ALTLIK SHIM	ALTLIK VIDASI SHIM SCREW	ANAHTAR TORX KEY	
VRF90	AP10	D040	d16	Z06	40	16	40	8	6	APKT 1003	VRT 04 M2.5x6	T08
VRF90	AP10	D050	d22	Z07	50	22	40	8	7			
VRF90	AP10	D063	d22	Z08	63	22	40	8	8			
VRF90	AP10	D080	d27	Z09	80	27	50	8	9			
VRF90	AP10	D100	d32	Z10	100	32	50	8	10			

TAKIM KODU ORDERING CODE		TAKIM ÖLÇÜLERİ DIMENSIONS (mm)				KESİCİ UÇ ADET INSERT NUMBER	YEDEK PARÇALAR / SPARE PARTS						
							KESİCİ UÇ INSERT	BASKI PARÇASI WEDGE CLAMP	BASKI VIDASI SCREW	SIKMA VIDASI CLAMPING SCREW	ANAHTAR TORX KEY		
VRF	RD1003	D040	d16	Z04	40	16	40	5	4	RD.. 10 03	VRV 11 M4	VRT 06 M3.5x9	T15
VRF	RD1003	D050	d22	Z05	50	22	40	5	5				
VRF	RD1003	D063	d22	Z06	63	22	40	5	6				
VRF	RD1003	D080	d27	Z07	80	27	50	5	7				
VRF	RD1003	D100	d32	Z08	100	32	50	5	8				



TEKNİK ÇİZİM / TECHNICAL DRAWING

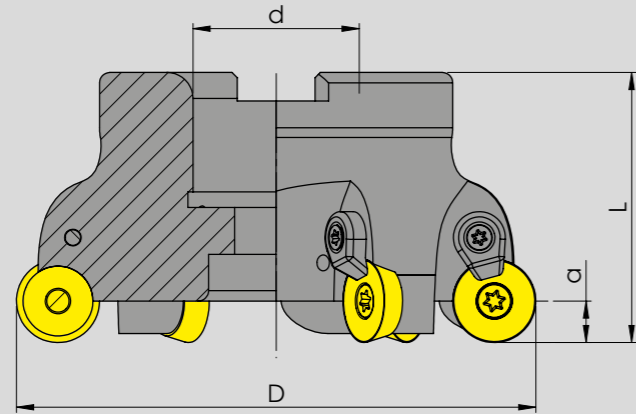

TAKIM KODU ORDERING CODE		TAKIM ÖLÇÜLERİ DIMENSIONS (mm)				KESİCİ UÇ ADET INSERT NUMBER	YEDEK PARÇALAR / SPARE PARTS				
		D	d	L	A						
VRF	RD12T03 D040 d16 Z04	40	16	40	6	4	RD.. 12 T03	VCP 03	VRT 09 M4x11	VRT 06 M3,5	T15
VRF	RD12T03 D050 d22 Z05	50	22	40	6	5					
VRF	RD12T03 D063 d22 Z06	63	22	40	6	6					
VRF	RD12T03 D080 d27 Z07	80	27	50	6	7					
VRF	RD12T03 D100 d32 Z08	100	32	50	6	8					



TEKNİK ÇİZİM / TECHNICAL DRAWING

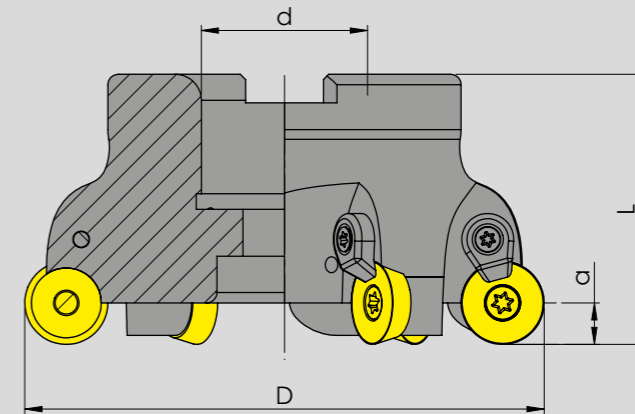

TAKIM KODU ORDERING CODE		TAKIM ÖLÇÜLERİ DIMENSIONS (mm)				KESİCİ UÇ ADET INSERT NUMBER	YEDEK PARÇALAR / SPARE PARTS				
		D	d	L	A						
VRF	RD1204 D040 d16 Z04	40	16	40	6	4	RD.. 12 04	VCP 03	VRT 09 M4x11	VRT 06 M3,5	T15
VRF	RD1204 D050 d22 Z05	50	22	40	6	5					
VRF	RD1204 D063 d22 Z06	63	22	40	6	6					
VRF	RD1204 D080 d27 Z07	80	27	50	6	7					
VRF	RD1204 D100 d32 Z08	100	32	50	6	8					



TEKNİK ÇİZİM / TECHNICAL DRAWING

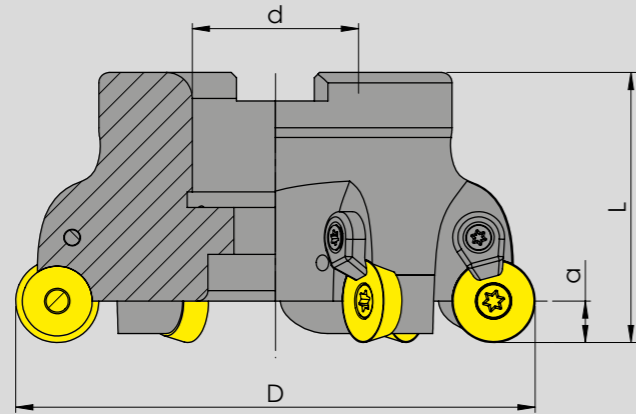

TAKIM KODU ORDERING CODE		TAKIM ÖLÇÜLERİ DIMENSIONS (mm)				KESİCİ UÇ ADET INSERT NUMBER	YEDEK PARÇALAR / SPARE PARTS							
		D	d	L	A									
VRF	RD1604	D063	d22	Z04	63	22	40	8	4	RD.. 16 04	VCP 04	VRT 12 M6	VRT 13 M5	T20
VRF	RD1604	D080	d27	Z05	80	27	50	8	5					
VRF	RD1604	D100	d32	Z06	100	32	50	8	6					
VRF	RD1604	D125	d40	Z07	125	40	65	8	7					



TEKNİK ÇİZİM / TECHNICAL DRAWING

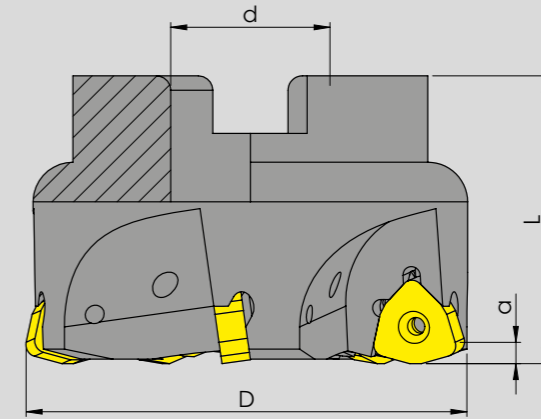

TAKIM KODU ORDERING CODE		TAKIM ÖLÇÜLERİ DIMENSIONS (mm)				KESİCİ UÇ ADET INSERT NUMBER	YEDEK PARÇALAR / SPARE PARTS					
		D	d	L	A							
VRFWN	09	D050	d22	Z04	50	22	45	5	4	WNMX 09T3	VRT 05 M3x9	T10
VRFWN	09	D052	d22	Z05	52	22	40	5	5			
VRFWN	09	D063	d22	Z05	63	22	45	5	5			
VRFWN	09	D066	22	Z06	66	22	40	5	6			
VRFWN	09	D080	d27	Z06	80	27	52	5	6			
VRFWN	09	D100	d32	Z07	100	32	60	5	7			
VRFWN	13	D050	d22	Z04	50	22	45	6	4			
VRFWN	13	D063	d22	Z05	63	22	45	6	5	WNMX 1305	VRT 09 M4x11	T15
VRFWN	13	D80	d27	Z06	80	27	52	6	6			
VRFWN	13	D100	d32	Z07	100	32	60	6	7			



TEKNİK ÇİZİM / TECHNICAL DRAWING

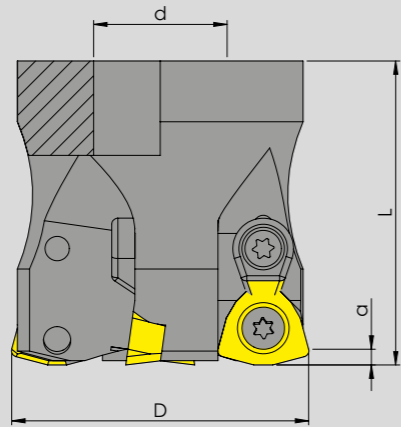

TAKIM KODU ORDERING CODE					TAKIM ÖLÇÜLERİ DIMENSIONS (mm)				KESİCİ UÇ ADET INSERT NUMBER	YEDEK PARÇALAR / SPARE PARTS				
					D	d	L	A						
VRFWD	13	D050	d22	Z04	50	22	40	5	4					
VRFWD	13	D063	d22	Z05	63	22	40	5	5	WDKT 1305	VCP 03	VRT 09 M4x11	VRT 13 M5	T15
VRFWD	13	D080	d27	Z06	80	27	50	5	6					
VRFWD	13	D100	d32	Z07	100	32	65	5	7					



TEKNİK ÇİZİM / TECHNICAL DRAWING

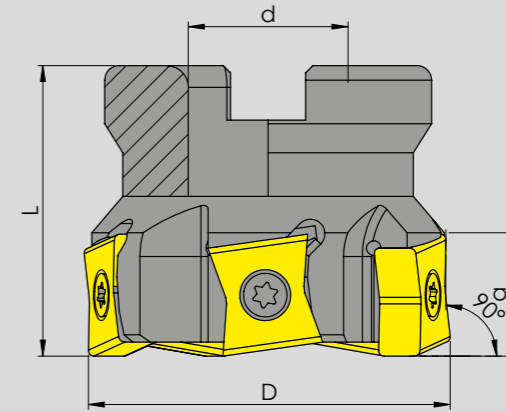

TAKIM KODU ORDERING CODE					TAKIM ÖLÇÜLERİ DIMENSIONS (mm)				KESİCİ UÇ ADET INSERT NUMBER	YEDEK PARÇALAR / SPARE PARTS				
					D	d	L	A						
VRF90LNR/L	15	D050	d22	Z05-T/L	50	22	40	5	5					
VRF90LNR/L	15	D063	d22	Z06-T/L	63	22	40	5	6					
VRF90LNR/L	15	D080	d22	Z07-T/L	80	27	40	5	7	LN.. 1506			VRT 09 M4x11	T15
VRF90LNR/L	15	D100	d32	Z08-T/L	100	32	60	5	8					
VRF90LNR/L	15	D125	d40	Z09-T/L	125	40	65	5	9					
VRF90LNR/L	15	D160	d40	Z10-T/L	160	40	65	5	10					



TEKNİK ÇİZİM / TECHNICAL DRAWING

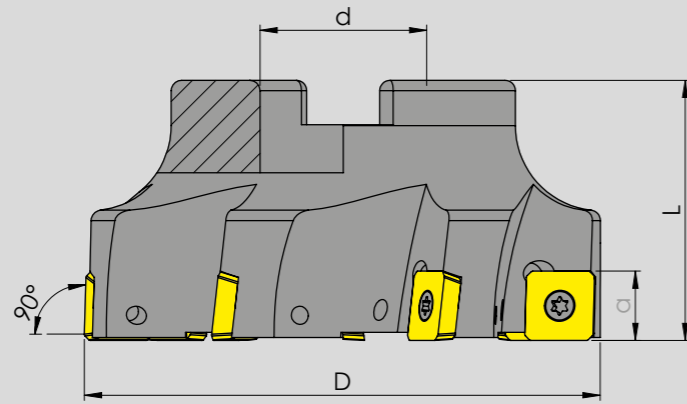

TAKIM KODU ORDERING CODE	TAKIM ÖLÇÜLERİ DIMENSIONS (mm)				KESİCİ UÇ ADET INSERT NUMBER	YEDEK PARÇALAR / SPARE PARTS				
	D	d	L	A		KESİCİ UÇ INSERT	BASKI PARÇASI WEDGE CLAMP	BASKI VİDASI SCREW	SIKMA VİDASI CLAMPING SCREW	ANAHTAR TORX KEY
VRF90 SE1203 D050 d22 Z04	50	22	40	8	4					
VRF90 SE1203 D063 d22 Z05	63	22	40	8	5	SEET 12 03		VRT 09 M3,5x9	T15	
VRF90 SE1203 D080 d22 Z06	80	27	50	8	6					
VRF90 SE1203 D100 d32 Z07	100	32	65	8	7					



TEKNİK ÇİZİM / TECHNICAL DRAWING

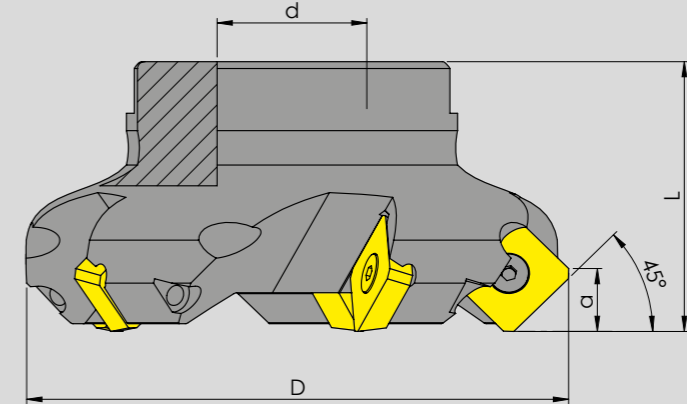

TAKIM KODU ORDERING CODE	TAKIM ÖLÇÜLERİ DIMENSIONS (mm)				KESİCİ UÇ ADET INSERT NUMBER	YEDEK PARÇALAR / SPARE PARTS				
	D	d	L	A		KESİCİ UÇ INSERT	BASKI PARÇASI WEDGE CLAMP	BASKI VİDASI SCREW	SIKMA VİDASI CLAMPING SCREW	ANAHTAR TORX KEY
VRF45 SE12T3 D050 d22 Z04	50	27	40	6	4	SEET 12 T3		VRT 09 M3,5x9	T15	
VRF45 SE12T3 D063 d27 Z05	63	27	40	6	5					
VRF45 SE12T3 D080 d27 Z06	80	27	50	6	6					
VRF45 SE12T3 D100 d32 Z08	100	27	50	6	8					
VRF45 SE12T3 D125 d40 Z10	125	40	62	6	10					
VRF45 SE12T3 D160 d40 Z12	160	40	62	6	12					



TEKNİK ÇİZİM / TECHNICAL DRAWING

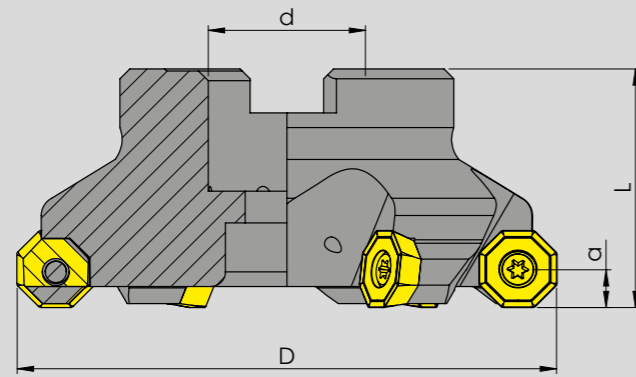

TEKNİK ÇİZİM / TECHNICAL DRAWING

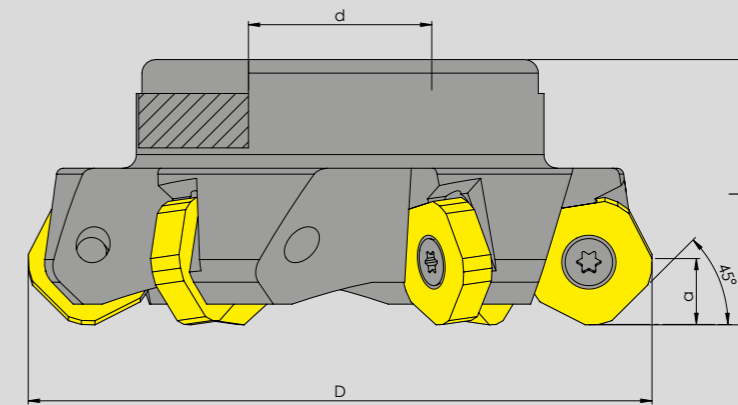

TAKIM KODU ORDERING CODE	TAKIM ÖLÇÜLERİ DIMENSIONS (mm)				KESİCİ UÇ ADET INSERT NUMBER	YEDEK PARÇALAR / SPARE PARTS				
	D	d	L	A		KESİCİ UÇ INSERT	BASKI PARÇASI WEDGE CLAMP	BASKI VİDASI SCREW	SIKMA VİDASI CLAMPING SCREW	ANAHTAR TORX KEY
VRF45 OD06 D050 d22 Z04	50	22	40	4	4	OD.. 06 05			VRT 11 M5	T20
VRF45 OD06 D063 d22 Z05	63	22	40	4	5					
VRF45 OD06 D080 d27 Z06	80	27	50	4	6					
VRF45 OD06 D100 d32 Z07	100	32	50	4	7					
VRF45 OD06 D125 d40 Z08	125	40	60	4	8					
VRF45 OD06 D160 d40 Z09	160	40	60	4	9					
VRF45 OD06 D200 d60 Z12	200	60	60	4	12					

TAKIM KODU ORDERING CODE	TAKIM ÖLÇÜLERİ DIMENSIONS (mm)				KESİCİ UÇ INSERT	YEDEK PARÇALAR / SPARE PARTS				
	D	d	L	A		KESİCİ UÇ INSERT	BASKI PARÇASI WEDGE CLAMP	BASKI VİDASI SCREW	SIKMA VİDASI CLAMPING SCREW	ANAHTAR TORX KEY
VRF45 PN12 D063 d22 Z05	63	22	40	4	PN.. 12 05	5			VRT 11 M5	T20
VRF45 PN12 D080 d27 Z06	80	27	50	4		6				
VRF45 PN12 D100 d32 Z07	100	32	50	4		7				



TEKNİK ÇİZİM / TECHNICAL DRAWING

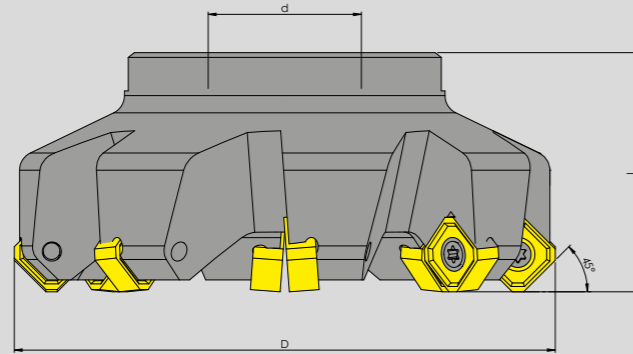

TEKNİK ÇİZİM / TECHNICAL DRAWING

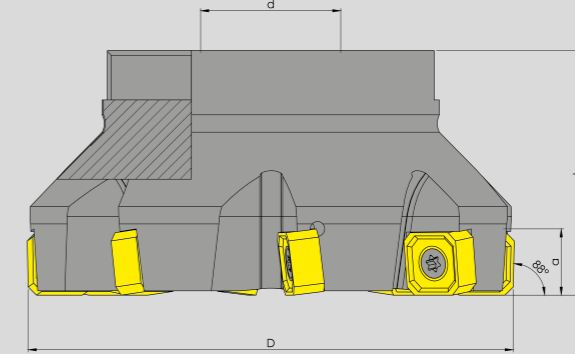

TAKIM KODU ORDERING CODE		TAKIM ÖLÇÜLERİ DIMENSIONS (mm)				KESİCİ UÇ ADET INSERT NUMBER	YEDEK PARÇALAR / SPARE PARTS					
							KESİCİ UÇ INSERT	BASKI PARÇASI WEDGE CLAMP	BASKI VİDASI SCREW	SIKMA VİDASI CLAMPING SCREW	ANAHTAR TORX KEY	
VRF45	SN1205	D050	d22	Z04	50	27	40	6	4	SNMX 1205	VRT 13 M4	T15
VRF45	SN1205	D063	d27	Z05	63	27	40	6	5			
VRF45	SN1205	D080	d27	Z06	80	27	50	6	6			
VRF45	SN1205	D100	d32	Z08	100	27	50	6	8			
VRF45	SN1205	D125	d40	Z10	125	40	62	6	10			
VRF45	SN1205	D160	d40	Z12	160	40	62	6	12			

TAKIM KODU ORDERING CODE		TAKIM ÖLÇÜLERİ DIMENSIONS (mm)				KESİCİ UÇ ADET INSERT NUMBER	YEDEK PARÇALAR / SPARE PARTS					
							KESİCİ UÇ INSERT	BASKI PARÇASI WEDGE CLAMP	BASKI VİDASI SCREW	SIKMA VİDASI CLAMPING SCREW	ANAHTAR TORX KEY	
VRF88	SN1205	D050	d22	Z04	50	27	40	6	4	SNMX 1205	VRT 13 M4	T15
VRF88	SN1205	D063	d27	Z06	63	27	40	6	6			
VRF88	SN1205	D080	d27	Z07	80	27	50	6	7			
VRF88	SN1205	D080	d27	Z09	80	27	50	6	9			
VRF88	SN1205	D100	d32	Z08	100	27	50	6	8			
VRF88	SN1205	D125	d40	Z10	125	40	62	6	10			



TEKNİK ÇİZİM / TECHNICAL DRAWING

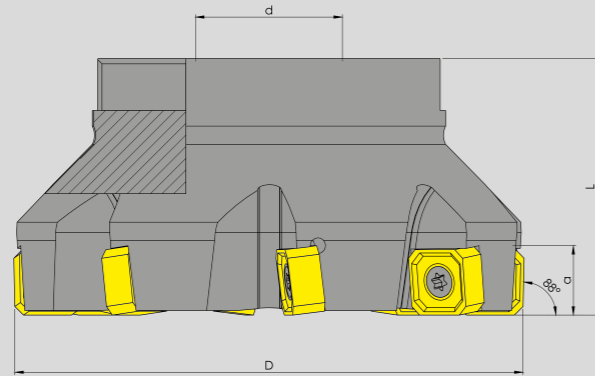

TEKNİK ÇİZİM / TECHNICAL DRAWING

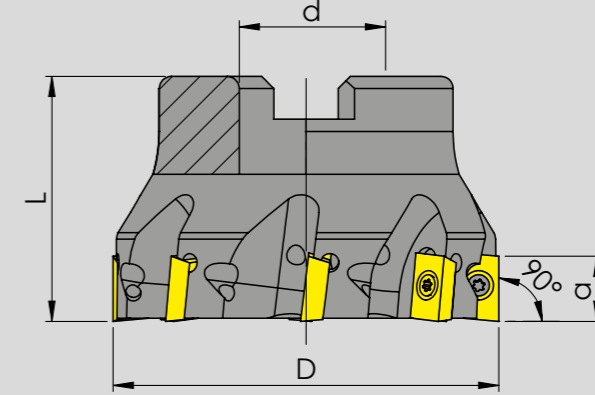

TAKIM KODU ORDERING CODE					TAKIM ÖLÇÜLERİ DIMENSIONS (mm)				KESİCİ UÇ ADET INSERT NUMBER	YEDEK PARÇALAR / SPARE PARTS				
D	d	L	A		KESİCİ UÇ INSERT	BASKI PARÇASI WEDGE CLAMP	BASKI VİDASI SCREW	SIKMA VİDASI CLAMPING SCREW	ANAHTAR TORX KEY					
VRF88	SN1206	D050	d22	Z04	50	27	40	6	4	SNMX 1206			VRT 09 M4	T15
VRF88	SN1206	D063	d27	Z05	63	27	40	6	5					
VRF88	SN1206	D080	d27	Z06	80	27	50	6	6					
VRF88	SN1206	D100	d32	Z08	100	27	50	6	8					
VRF88	SN1206	D125	d40	Z10	125	40	62	6	10					
VRF88	SN1206	D160	d40	Z12	160	40	62	6	12					

TAKIM KODU ORDERING CODE					TAKIM ÖLÇÜLERİ DIMENSIONS (mm)				KESİCİ UÇ ADET INSERT NUMBER	YEDEK PARÇALAR / SPARE PARTS				
D	d	L	A		KESİCİ UÇ INSERT	BASKI PARÇASI WEDGE CLAMP	BASKI VİDASI SCREW	SIKMA VİDASI CLAMPING SCREW	ANAHTAR TORX KEY					
VRF90	AP1135	D040	d16	Z05	40	16	40	9	5	AP. 1135			VRT 04 M2,5x7	T08
VRF90	AP1135	D050	d22	Z06	50	22	40	9	6					
VRF90	AP1135	D063	d22	Z07	63	22	40	9	7					

VRF90 AP11 R390 ÜRÜN / PRODUCT 90°



TEKNİK ÇİZİM / TECHNICAL DRAWING

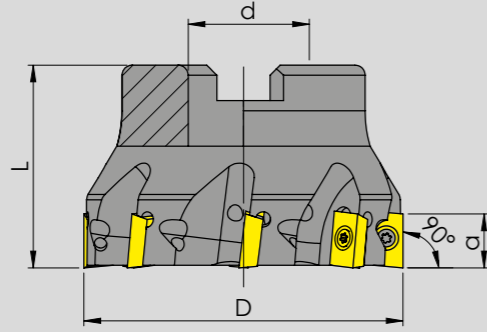

TAKIM KODU ORDERING CODE	TAKIM ÖLÇÜLERİ DIMENSIONS (mm)				KESİCİ UÇ ADET INSERT NUMBER	YEDEK PARÇALAR / SPARE PARTS				
	D	d	L	A		KESİCİ UÇ INSERT	BASKI PARÇASI WEDGE CLAMP	BASKI VIDASI SCREW	SIKMA VIDASI CLAMPING SCREW	ANAHTAR TORX KEY
VRF90 AP11R390 D040 d16 Z05	40	16	40	9	5	AP. 11 R390			VRT 04 M2,5x7	T08
VRF90 AP11R390 D050 d22 Z06	50	22	40	9	6					
VRF90 AP11R390 D063 d22 Z07	63	22	40	9	7					
VRF90 AP11R390 D080 d27 Z08	80	27	50	9	8	AP. 17 R390			VRT 07 M3,5x11	T15
VRF90 AP17R390 D040 d16 Z04	40	16	40	14	4					
VRF90 AP17R390 D050 d22 Z05	50	22	40	14	5					
VRF90 AP17R390 D063 d22 Z06	63	22	40	14	6					
VRF90 AP17R390 D080 d27 Z07	80	27	50	14	7	AP. 18 R390			VRT 09 M4x11	T15
VRF90 AP17R390 D100 d32 Z08	100	32	50	14	8					
VRF90 AP17R390 D125 d40 Z09	125	40	60	14	9					
VRF90 AP18R390 D040 d16 Z04	40	16	40	15	4	AP. 18 R390			VRT 09 M4x11	T15
VRF90 AP18R390 D050 d22 Z05	50	22	40	15	5					
VRF90 AP18R390 D063 d22 Z06	63	22	40	15	6					
VRF90 AP18R390 D080 d27 Z07	80	27	50	15	7					
VRF90 AP18R390 D100 d32 Z08	100	32	60	15	8					

VRF90 AX17 ÜRÜN / PRODUCT 90°



TEKNİK ÇİZİM / TECHNICAL DRAWING

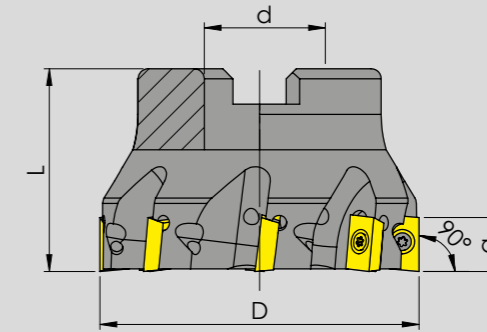

TAKIM KODU ORDERING CODE	TAKIM ÖLÇÜLERİ DIMENSIONS (mm)				KESİCİ UÇ ADET INSERT NUMBER	YEDEK PARÇALAR / SPARE PARTS				
	D	d	L	A		KESİCİ UÇ INSERT	BASKI PARÇASI WEDGE CLAMP	BASKI VIDASI SCREW	SIKMA VIDASI CLAMPING SCREW	ANAHTAR TORX KEY
VRF90 AX17 D040 d16 Z04	40	16	40	15	4	AX. 1705			VRT 09 M4x11	T15
VRF90 AX17 D050 d22 Z05	50	22	40	15	5					
VRF90 AX17 D063 d22 Z06	63	22	40	15	6					
VRF90 AX17 D080 d27 Z07	80	27	50	15	7					



TEKNİK ÇİZİM / TECHNICAL DRAWING

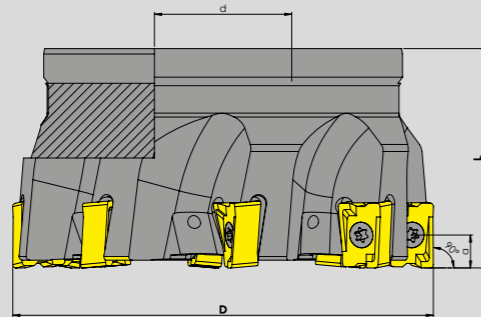

TAKIM KODU ORDERING CODE		TAKIM ÖLÇÜLERİ DIMENSIONS (mm)				KESİCİ UÇ ADET INSERT NUMBER		YEDEK PARÇALAR / SPARE PARTS						
D	d	L	A			KESİCİ UÇ INSERT	BASKI PARÇASI WEDGE CLAMP	BASKI VIDASI SCREW	SIKMA VIDASI CLAMPING SCREW	ANAHTAR TORX KEY				
VRF90	LN13	D063	d22	Z06	63	22	40	12	6					
VRF90	LN13	D080	d27	Z07	80	27	50	12	7	LNGX. 1307				
VRF90	LN13	D100	s32	Z08	100	32	50	12	8					
VRF90	LN13	D125	d40	Z10	125	40	60	12	10					

TEKNİK ÇİZİM / TECHNICAL DRAWING

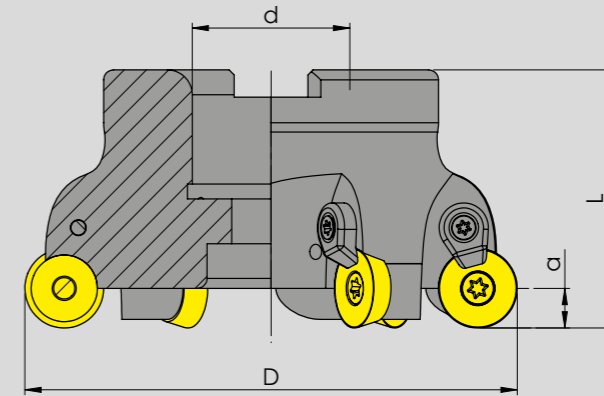

TAKIM KODU ORDERING CODE		TAKIM ÖLÇÜLERİ DIMENSIONS (mm)				KESİCİ UÇ ADET INSERT NUMBER		YEDEK PARÇALAR / SPARE PARTS						
D	d	L	A			KESİCİ UÇ INSERT	BASKI PARÇASI WEDGE CLAMP	BASKI VIDASI SCREW	SIKMA VIDASI CLAMPING SCREW	ANAHTAR TORX KEY				
VRF	RP10	D040	d16	Z04	40	16	40	5	4					
VRF	RP10	D050	d22	Z05	50	22	40	5	5					
VRF	RP10	D063	d22	Z06	63	22	40	5	6					
VRF	RP10	D080	d27	Z07	80	27	50	5	7					
VRF	RP10	D100	d32	Z08	100	32	50	5	8					
VRF	RP12	D040	d16	Z04	40	16	40	5	4					
VRF	RP12	D050	d22	Z05	50	22	40	5	5					
VRF	RP12	D063	d22	Z06	63	22	40	5	6					
VRF	RP12	D080	d27	Z07	80	27	50	5	7					
VRF	RP12	D100	d32	Z08	100	32	50	5	8					



TEKNİK ÇİZİM / TECHNICAL DRAWING

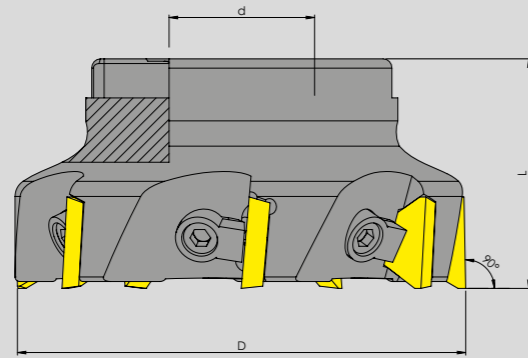

TAKIM KODU ORDERING CODE		TAKIM ÖLÇÜLERİ DIMENSIONS (mm)				KESİCİ UÇ ADET INSERT NUMBER	YEDEK PARÇALAR / SPARE PARTS							
							KESİCİ UÇ INSERT	BASKI BARÇASI WEDGE CLAMP	BASKI VIDASI SCREW	ALTLIK VIDASI SHIM SCREW	ANAHTAR ALLEN KEY			
VRF90C	TP22	D063	d22	Z05	63	22	50	18	5					
VRF90C	TP22	D080	d27	Z06	80	27	50	18	6					
VRF90C	TP22	D100	d32	Z07	100	32	50	18	7	TP. 22 04	VTP 001	VKP 002 M8	VSP 01 M8	AA4
VRF90C	TP22	D125	d40	Z08	125	40	62	18	8					
VRF90C	TP22	D160	d40	Z09	160	40	62	18	9					

TEKNİK ÇİZİM / TECHNICAL DRAWING

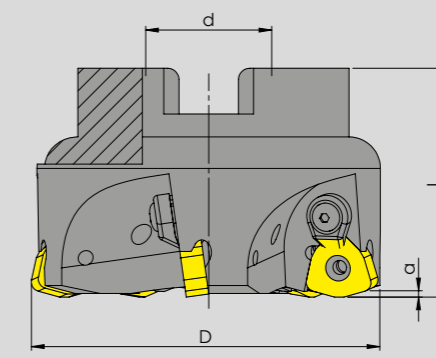

TAKIM KODU ORDERING CODE		TAKIM ÖLÇÜLERİ DIMENSIONS (mm)				KESİCİ UÇ ADET INSERT NUMBER	YEDEK PARÇALAR / SPARE PARTS							
							KESİCİ UÇ INSERT	BASKI BARÇASI WEDGE CLAMP	BASKI VIDASI SCREW	ALTLIK VIDASI SHIM SCREW	ANAHTAR TORX KEY			
VRFJD	JD1204	D050	d22	Z04	50	22	40	2	4					
VRFJD	JD1204	D063	d22	Z05	63	22	40	2	5	JD. 12 04	VCP 03	VRT 09 M4x11	VRT 09 M4x11	T15
VRFJD	JD1204	D080	d27	Z06	80	27	50	2	6					



**PARMAK
FREZE TAKIMLARI**

End milling toolholders

www.vorgen.com



TEKNİK ÇİZİM / TECHNICAL DRAWING

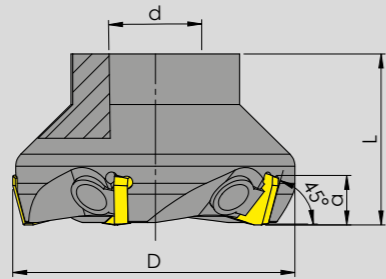

TAKIM KODU ORDERING CODE	TAKIM ÖLÇÜLERİ DIMENSIONS (mm)				KESİCİ UÇ ADET INSERT NUMBER	YEDEK PARÇALAR / SPARE PARTS								
	D	d	L	A		KESİCİ UÇ INSERT	BASKI BARÇASI WEDGE CLAMP	BASKI VIDASI SCREW	ALTLIK VIDASI SHIM SCREW	ANAHTAR ALLEN KEY				
VRF45	SEK12	D050	d22	Z04	50	22	40	5	4					
VRF45	SEK12	D063	d22	Z05	63	22	40	5	5	SEKN	VKP	VRV		AA4
VRF45	SEK12	D080	d27	Z06	80	27	50	5	6	1203	002 M8	07 M8		
VRF45	SEK12	D100	d32	Z08	100	32	50	5	8					

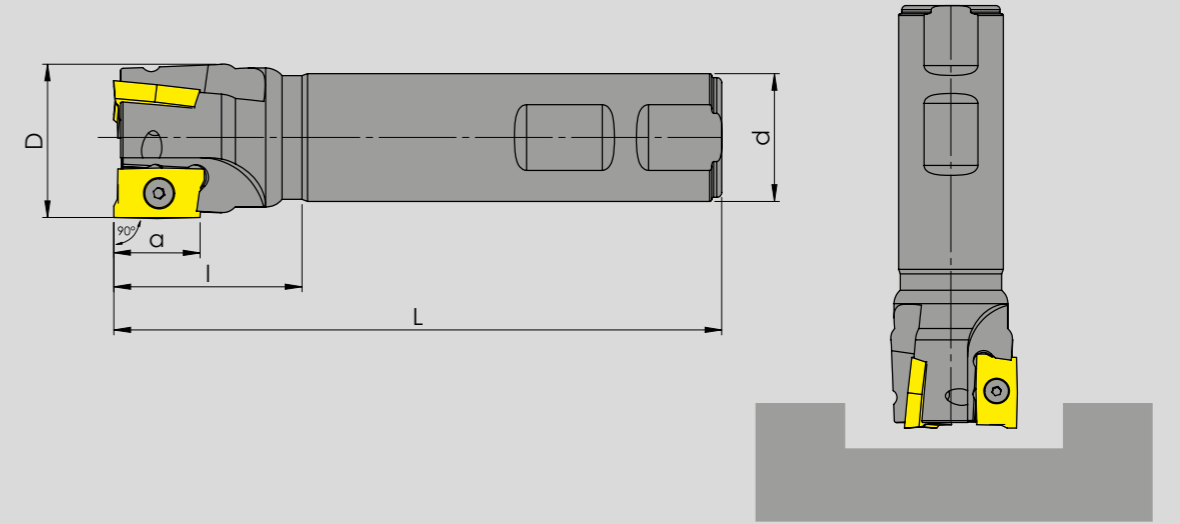

TAKIM KODU ORDERING CODE	TAKIM ÖLÇÜLERİ DIMENSIONS (mm)			KESİCİ UÇ ADET INSERT NUMBER	KESİCİ UÇ INSERT	YEDEK PARÇALAR / SPARE PARTS		
	D	d	L			BASKI VIDASI SCREW	ANAHTAR TORX KEY	
SPAP16	S02 D25 d25 L120	25	25	120	2	APKT 1604	VRT 09 M4x11	T15
SPAP16	S02 D30 d25 L120	30	25	120	2			
SPAP16	S03 D32 d25 L120	32	25	120	3			
SPAP16	S03 D35 d25 L120	35	25	120	3			
SPAP16	S03 D40 d32 L120	40	32	120	3			
SPAP16	S04 D45 d32 L120	45	32	120	4			
SPAP16	S05 D50 d32 L120	50	32	120	5			
SPAP16	S02 D25 d25 L150	25	25	150	2			
SPAP16	S02 D30 d25 L150	30	25	150	2			
SPAP16	S03 D32 d25 L150	32	25	150	3			
SPAP16	S03 D35 d25 L150	35	25	150	3			
SPAP16	S03 D40 d32 L150	40	32	150	3			
SPAP16	S04 D45 d32 L150	45	32	150	4			
SPAP16	S05 D50 d32 L150	50	32	150	5			
SPAP16	S02 D25 d25 L200	25	25	200	2			
SPAP16	S02 D30 d25 L200	30	25	200	2			
SPAP16	S03 D32 d25 L200	32	25	200	3			
SPAP16	S03 D35 d25 L200	35	25	200	3			
SPAP16	S03 D40 d32 L200	40	32	200	3			
SPAP16	S04 D45 d32 L200	45	32	200	4			
SPAP16	S05 D50 d32 L200	50	32	200	5			

SPAP 10

ÜRÜN / PRODUCT

90°



TEKNİK ÇİZİM / TECHNICAL DRAWING

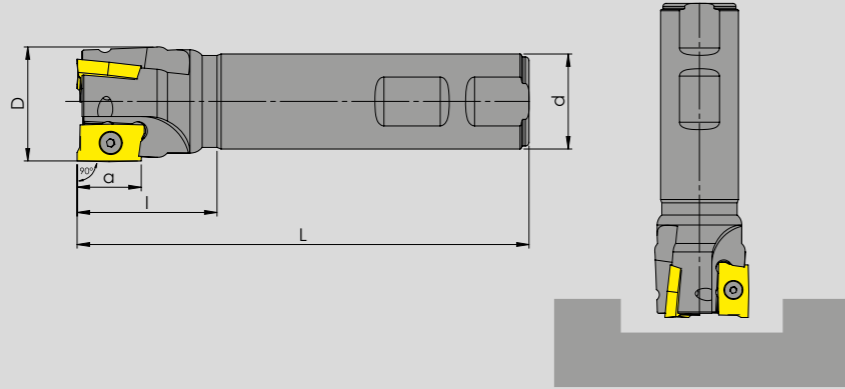

TAKIM KODU ORDERING CODE	TAKIM ÖLÇÜLERİ DIMENSIONS (mm)	KESİCİ UÇ ADET INSERT NUMBER	KESİCİ UÇ INSERT	YEDEK PARÇALAR / SPARE PARTS	
				BASKI VİDASI SCREW	ANAHTAR TORX KEY
SPAP10	S01 D10 d10 L100	1	APKT 1003	VRT 04 M2,5x5	T08
SPAP10	S01 D12 d12 L100	1			
SPAP10	S01 D14 d14 L100	1			
SPAP10	S02 D16 d16 L100	2			
SPAP10	S02 D18 d16 100	2			
SPAP10	S03 D20 d20 L100	3			
SPAP10	S03 D22 d20 L100	3			
SPAP10	S03 D25 d25 L100	3			
SPAP10	S03 D28 d25 L100	3			
SPAP10	S04 D30 d25 L100	4			

TAKIM KODU ORDERING CODE	TAKIM ÖLÇÜLERİ DIMENSIONS (mm)	KESİCİ UÇ ADET INSERT NUMBER	KESİCİ UÇ INSERT	YEDEK PARÇALAR / SPARE PARTS	
				BASKI VİDASI SCREW	ANAHTAR TORX KEY
SPAP10	S01 D10 d10 L120	1	APKT 1003	VRT 04 M2,5x5	T08
SPAP10	S01 D12 d12 L120	1			
SPAP10	S01 D14 d14 L120	1			
SPAP10	S02 D16 d16 L120	2			
SPAP10	S02 D18 d16 L120	2			
SPAP10	S03 D20 d20 L120	3			
SPAP10	S03 D22 d20 L120	3			
SPAP10	S03 D25 d25 L120	3			
SPAP10	S03 D28 d25 L120	3			
SPAP10	S04 D30 d25 L120	4			
SPAP10	S04 D32 d25 L120	4			
SPAP10	S04 D35 d25 L120	4			
SPAP10	S05 D40 d25 L120	5			
SPAP10	S01 D10 d10 L150	1			
SPAP10	S01 D12 d12 L150	1			
SPAP10	S01 D14 d14 L150	1			
SPAP10	S02 D16 d16 L150	2			
SPAP10	S02 D18 d16 L150	2			
SPAP10	S03 D20 d20 L150	3			
SPAP10	S03 D22 d20 L150	3			
SPAP10	S03 D25 d25 L150	3			
SPAP10	S03 D28 d25 L150	3			
SPAP10	S04 D30 d25 L150	4			
SPAP10	S04 D32 d25 L150	4			
SPAP10	S04 D35 d25 L150	4			
SPAP10	S05 D40 d32 L150	5			
SPAP10	S02 D16 d16 L200	2			
SPAP10	S02 D18 d16 L200	2			
SPAP10	S03 D20 d20 L200	3			
SPAP10	S03 D22 d20 L200	3			
SPAP10	S03 D25 d25 L200	3			
SPAP10	S03 D28 d25 L200	3			
SPAP10	S04 D30 d25 L200	4			
SPAP10	S04 D32 d25 L200	4			
SPAP10	S04 D35 d25 L200	4			
SPAP10	S05 D40 d32 L200	5			
SPAP10	S02 D16 d16 L250	2			
SPAP10	S02 D18 d16 L250	2			
SPAP10	S03 D20 d20 L250	3			
SPAP10	S03 D25 d25 L250	3			

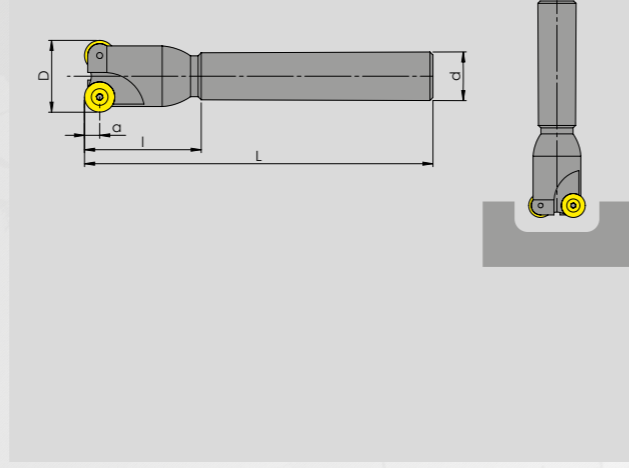

TAKIM KODU ORDERING CODE	TAKIM ÖLÇÜLERİ DIMENSIONS (mm)	KESİCİ UÇ ADET INSERT NUMBER	KESİCİ UÇ INSERT	YEDEK PARÇALAR / SPARE PARTS	
				BASKI VİDASI SCREW	ANAHTAR ALLEN KEY
	D d L				
SPRD1204	S02 D25 d25 L120	2			
SPRD1204	S02 D28 d25 L120	2			
SPRD1204	S02 D30 d25 L120	2			
SPRD1204	S03 D32 d25 L120	3			
SPRD1204	S03 D35 d32 L120	3			
SPRD1204	S03 D40 d32 L120	3			
SPRD1204	S02 D25 d25 L150	2			
SPRD1204	S02 D28 d25 L150	2			
SPRD1204	S02 D30 d25 L150	2			
SPRD1204	S03 D32 d25 L150	3			
SPRD1204	S03 D35 d32 L150	3			
SPRD1204	S03 D40 d32 L150	3			
SPRD1204	S02 D25 d25 L200	2			
SPRD1204	S02 D28 d25 L200	2			
SPRD1204	S02 D30 d25 L200	2			
SPRD1204	S03 D32 d25 L200	3			
SPRD1204	S03 D35 d32 L200	3			
SPRD1204	S03 D40 d32 L200	3			
SPRD1204	S02 D25 d25 L250	2			
SPRD1204	S02 D28 d25 L250	2			
SPRD1204	S02 D30 d25 L250	2			
SPRD1204	S03 D32 d25 L250	3			
SPRD1204	S03 D35 d32 L250	3			
SPRD1204	S03 D40 d32 L250	3			

RD..
1204

VRT 09
M4x11

T15

TAKIM KODU ORDERING CODE	TAKIM ÖLÇÜLERİ DIMENSIONS (mm)	KESİCİ UÇ ADET INSERT NUMBER	KESİCİ UÇ INSERT	YEDEK PARÇALAR / SPARE PARTS	
				BASKI VİDASI SCREW	ANAHTAR TORX KEY
	D d L				
SPRD1003	S02 D20 d20 L120	2			
SPRD1003	S02 D25 d25 L120	2			
SPRD1003	S03 D28 d25 L120	3			
SPRD1003	S03 D30 d25 L120	3			
SPRD1003	S03 D32 d25 L120	3			
SPRD1003	S03 D35 d25 L120	3			
SPRD1003	S03 D35 d32 L120	3			
SPRD1003	S04 D40 d32 L120	4			
SPRD1003	S02 D20 d20 L150	2			
SPRD1003	S02 D25 d25 L150	2			
SPRD1003	S03 D28 d25 L150	3			
SPRD1003	S03 D30 d25 L150	3			
SPRD1003	S03 D32 d25 L150	3			
SPRD1003	S03 D35 d25 L150	3			
SPRD1003	S03 D35 d32 L150	3			
SPRD1003	S04 D40 d32 L150	4			
SPRD1003	S02 D20 d20 L200	2			
SPRD1003	S02 D25 d25 L200	2			
SPRD1003	S03 D28 d25 L200	3			
SPRD1003	S03 D30 d25 L200	3			
SPRD1003	S03 D32 d25 L200	3			
SPRD1003	S03 D35 d25 L200	3			
SPRD1003	S03 D35 d32 L200	3			
SPRD1003	S04 D40 d32 L200	4			
SPRD1003	S02 D20 d20 L250	2			
SPRD1003	S02 D25 d25 L250	2			

RD..
1003

VRT 06
M3,5x9

T15

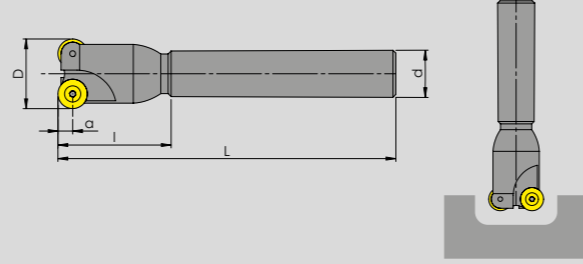

TAKIM KODU ORDERING CODE	TAKIM ÖLÇÜLERİ DIMENSIONS (mm)	KESİCİ UÇ ADET INSERT NUMBER	KESİCİ UÇ INSERT	YEDEK PARÇALAR / SPARE PARTS	
				BASKI VİDASI SCREW	ANAHTAR TORX KEY
SPRP	1003 S02 D20 d20 L120	2	RP. 1003	VRT 06 M3,5x9	T15
SPRP	1003 S02 D25 d25 L120	2			
SPRP	1003 S03 D30 d25 L120	3			
SPRP	1003 S03 D32 d25 L120	3			
SPRP	1003 S03 D35 d32 L120	3			
SPRP	1003 S02 D20 d20 L150	2			
SPRP	1003 S02 D25 d25 L150	2			
SPRP	1003 S03 D30 d25 L150	3			
SPRP	1003 S03 D32 d25 L150	3			
SPRP	1003 S03 D35 d32 L150	3			
SPRP	1204 S02 D25 d25 L120	2	RP. 1204	VRT 06 M4x11	T15
SPRP	1204 S02 D30 d25 L120	2			
SPRP	1204 S03 D32 d25 L120	3			
SPRP	1204 S03 D35 d32 L120	3			
SPRP	1204 S02 D25 d25 L150	2			
SPRP	1204 S02 D30 d25 L150	2			
SPRP	1204 S03 D32 d25 L150	3			
SPRP	1204 S03 D35 d32 L150	3			



TAKIM KODU ORDERING CODE	TAKIM ÖLÇÜLERİ DIMENSIONS (mm)	KESİCİ UÇ ADET INSERT NUMBER	KESİCİ UÇ INSERT	YEDEK PARÇALAR / SPARE PARTS	
				BASKI VİDASI SCREW	ANAHTAR TORX KEY
SPWN 06	S02 D16 d16 L150H	2	WNMX 06	VRT 04 M2,5x5	T08
SPWN06	S02 D20 d20 L150H	2			
SPWN09	S02 D25 d25 L150H	2	WNMX 09	VRT 05 M3x8	T10
SPWN09	S02 D26 d25 L150H	2			

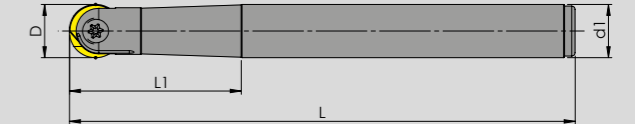

TAKIM KODU ORDERING CODE	TAKIM ÖLÇÜLERİ DIMENSIONS (mm)	KESİCİ UÇ INSERT	YEDEK PARÇALAR / SPARE PARTS	
			BASKI VİDASI SCREW	ANAHTAR TORX KEY
BTKR08	10-110	Q8 WLTR	VKV 01 M3	T08
BTKR10	12-130	Q10 WLTR	VKV 02 M4	T15
BTKR12	12-130	Q12 WLTR	VKV 03 M5	T20
BTKR16	16-175	Q16 WLTR	VKV 04 M5	T20
BTKR20	20-200	Q20 WLTR	VKV 05 M6	T20
BTKR25	25-200	Q25 WLTR	VKV 05 M6	T20
BTKR32	32-200	Q32 WLTR	VKV 06 M8	T30

SPLN 10-15 ÜRÜN / PRODUCT 90°



TEKNİK ÇİZİM / TECHNICAL DRAWING

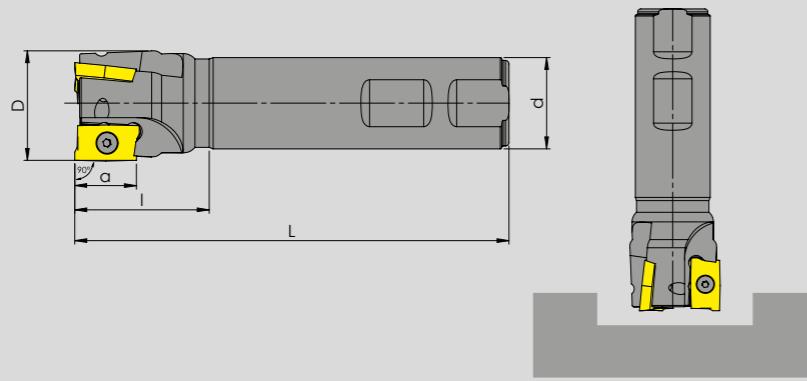

TAKIM KODU ORDERING CODE		TAKIM ÖLÇÜLERİ DIMENSIONS (mm)			KESİCİ UÇ ADET INSERT NUMBER	KESİCİ UÇ INSERT	YEDEK PARÇALAR / SPARE PARTS	
		D	d	L			BASKI VIDASI SCREW	ANAHTAR TORX KEY
SPLN10	S02 D18 d16 L150	18	16	150	2	LNMT. 1006	VRT 05 M3x8	T10
SPLN10	S02 D20 d20 L150	20	20	150	2			
SPLN10	S02 D21 d20 L150	21	20	150	2			
SPLN10	S03 D25 d25 L150	25	25	150	3			
SPLN10	S03 D26 d25 L150	26	25	150	3	LNMT. 1510	VRT 09 M4x11	T15
SPLN15	S02 D32 d32 L200	32	32	200	2			
SPLN15	S02 D33 d32 L200	33	32	200	2			

SPLO 15 ÜRÜN / PRODUCT 90°



TEKNİK ÇİZİM / TECHNICAL DRAWING

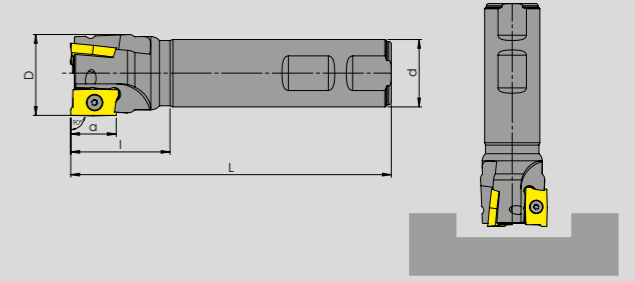

TAKIM KODU ORDERING CODE		TAKIM ÖLÇÜLERİ DIMENSIONS (mm)			KESİCİ UÇ ADET INSERT NUMBER	KESİCİ UÇ INSERT	YEDEK PARÇALAR / SPARE PARTS	
		D	d	L			BASKI VIDASI SCREW	ANAHTAR TORX KEY
SPLO 15	S02 D25 d25 L150	25	25	150	2	LO.. 15	VRT 06 M3,5x9	T15
SPLO 15	S03 D32 d25 L150	32	25	150	3			

SPXN 06 ÜRÜN / PRODUCT

TEKNİK ÇİZİM / TECHNICAL DRAWING

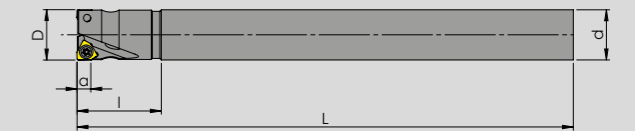

TAKIM KODU ORDERING CODE		TAKIM ÖLÇÜLERİ DIMENSIONS (mm)			KESİCİ UÇ ADET INSERT NUMBER	KESİCİ UÇ INSERT	YEDEK PARÇALAR / SPARE PARTS	
		D	d	L			BASKI VIDASI SCREW	ANAHTAR TORX KEY
SPXN 06H	S02 D21 d20 L200	21	20	200	2	XN.. 06	VRT 05 M3x8	T10
SPXN 06H	S03 D26 d25 L200	26	25	200	3			
SPXN 06H	S04 D33 d32 L200	33	32	200	4			



TEKNİK ÇİZİM / TECHNICAL DRAWING

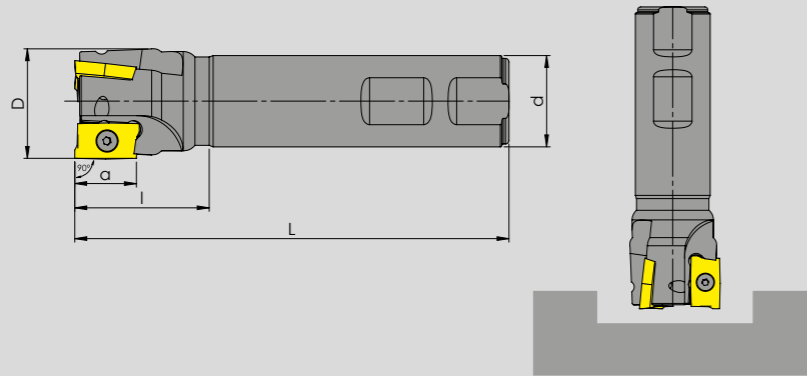

TAKIM KODU ORDERING CODE	TAKIM ÖLÇÜLERİ DIMENSIONS (mm)	KESİCİ UÇ ADET INSERT NUMBER	KESİCİ UÇ INSERT	YEDEK PARÇALAR / SPARE PARTS	
				BASKI VİDASI SCREW	ANAHTAR TORX KEY
SPAP11R390	S02 D16 d16 L100	2	AP. 11 R390	VRT 03 M2,5x7	T08
SPAP11R390	S03 D20 d20 L100	3			
SPAP11R390	S03 D25 d25 L100	3			
SPAP11R390	S04 D30 d25 L100	4			
SPAP11R390	S02 D16 d16 L120	2			
SPAP11R390	S03 D20 d20 L120	3			
SPAP11R390	S03 D25 d25 L120	3			
SPAP11R390	S04 D30 d25 L120	4			
SPAP11R390	S02 D16 d16 L150	2			
SPAP11R390	S03 D20 d20 L150	3			
SPAP11R390	S03 D25 d25 L150	3			
SPAP11R390	S04 D30 d25 L150	4			
SPAP11R390	S02 D16 d16 L200	2			
SPAP11R390	S03 D20 d20 L200	3			
SPAP11R390	S03 D25 d25 L200	3			



TEKNİK ÇİZİM / TECHNICAL DRAWING

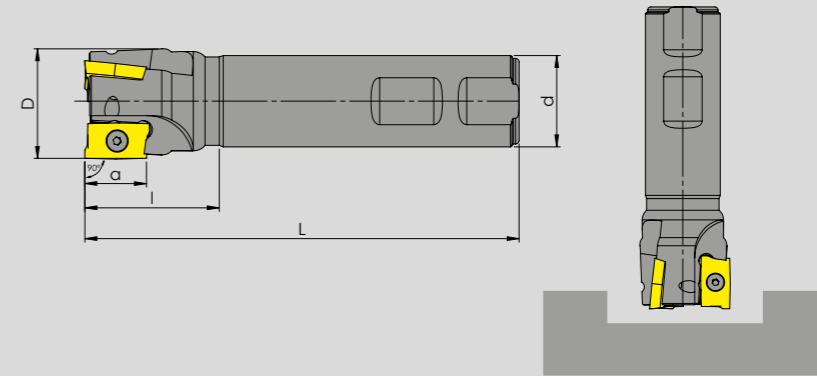

TAKIM KODU ORDERING CODE	TAKIM ÖLÇÜLERİ DIMENSIONS (mm)	KESİCİ UÇ ADET INSERT NUMBER	KESİCİ UÇ INSERT	YEDEK PARÇALAR / SPARE PARTS	
				BASKI VİDASI SCREW	ANAHTAR TORX KEY
SPAP17R390	S02 D25 d25 L100	2	AP. 17 R390	VRT 06 M3,5x9	T15
SPAP17R390	S03 D30 d25 L100	3			
SPAP17R390	S03 D32 d25 L100	3			
SPAP17R390	S02 D25 d25 L120	2			
SPAP17R390	S03 D30 d25 L120	3			
SPAP17R390	S03 D32 d25 L120	3			
SPAP17R390	S02 D25 d25 L150	2			
SPAP17R390	S03 D30 d25 L150	3			
SPAP17R390	S03 D32 d25 L150	3			



TEKNİK ÇİZİM / TECHNICAL DRAWING

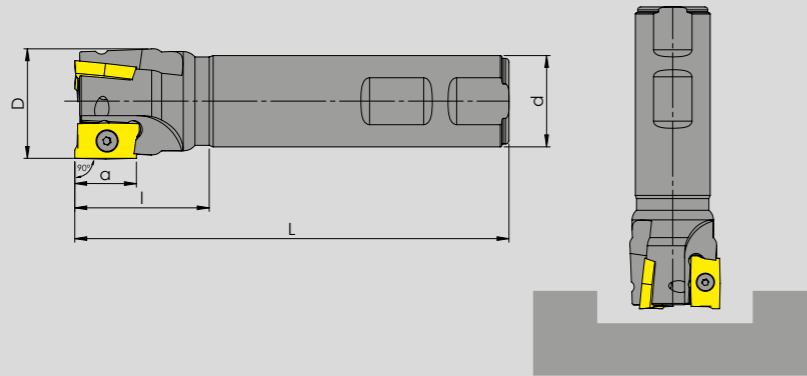

TAKIM KODU ORDERING CODE	TAKIM ÖLÇÜLERİ DIMENSIONS (mm)	KESİCİ UÇ ADET INSERT NUMBER	KESİCİ UÇ INSERT	YEDEK PARÇALAR / SPARE PARTS	
				BASKI VİDASI SCREW	ANAHTAR TORX KEY
SPAP1135	S02 D16 d16 L100	2	AP. 1135	VRT 03 M2,5x7	T08
SPAP1135	S03 D20 d20 L100	3			
SPAP1135	S03 D25 d25 L100	3			
SPAP1135	S02 D16 d16 L120	2			
SPAP1135	S03 D20 d20 L120	3			
SPAP1135	S03 D25 d25 L120	3			
SPAP1135	S02 D16 d16 L150	2			
SPAP1135	S03 D20 d20 L150	3			
SPAP1135	S03 D25 d25 L150	3			
SPAP1135	S02 D16 d16 L200	2			
SPAP1135	S03 D20 d20 L200	3			
SPAP1135	S03 D25 d25 L200	3			
SPAP1135	S02 D17 d16 L150	2			
SPAP1135	S03 D21 d20 L150	3			
SPAP1135	S03 D26 d25 L150	3			



TEKNİK ÇİZİM / TECHNICAL DRAWING

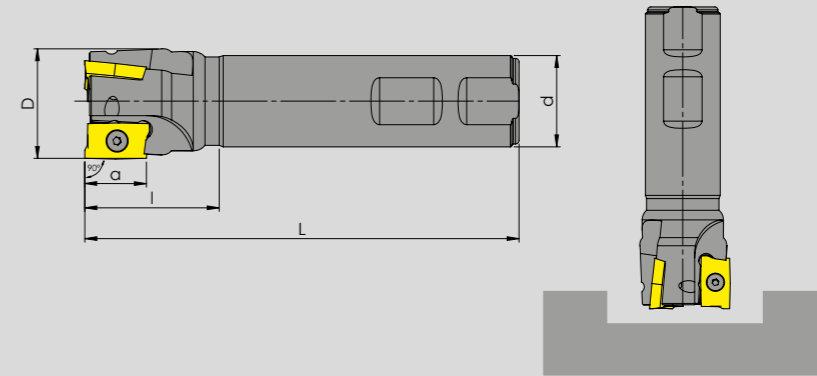

TAKIM KODU ORDERING CODE	TAKIM ÖLÇÜLERİ DIMENSIONS (mm)	KESİCİ UÇ ADET INSERT NUMBER	KESİCİ UÇ INSERT	YEDEK PARÇALAR / SPARE PARTS	
				BASKI VİDASI SCREW	ANAHTAR TORX KEY
SPAP11T3	S02 D16 d16 L100	2	AP. 11T3	VRT 03 M2,5x7	T08
SPAP11T3	S03 D20 d20 L100	3			
SPAP11T3	S03 D25 d25 L100	3			
SPAP11T3	S02 D16 d16 L120	2			
SPAP11T3	S03 D20 d20 L120	3			
SPAP11T3	S03 D25 d25 L120	3			
SPAP11T3	S02 D16 d16 L150	2			
SPAP11T3	S03 D20 d20 L150	3			
SPAP11T3	S03 D25 d25 L150	3			
SPAP11T3	S02 D16 d16 L200	2			
SPAP11T3	S03 D20 d20 L200	3			
SPAP11T3	S03 D25 d25 L200	3			
SPAP11T3	S02 D17 d16 L150	2			
SPAP11T3	S03 D21 d20 L150	3			
SPAP11T3	S03 D26 d25 L150	3			

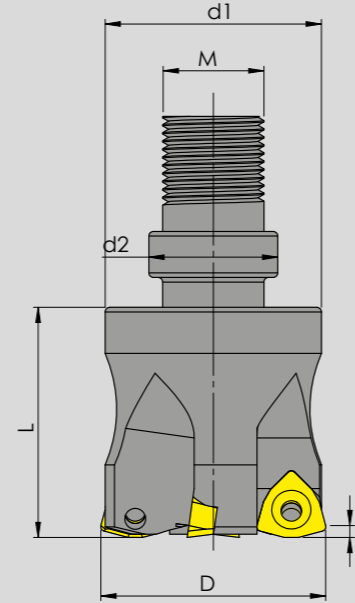

TAKIM KODU ORDERING CODE	TAKIM ÖLÇÜLERİ DIMENSIONS (mm)					KESİCİ UÇ ADET INSERT NUMBER	KESİCİ UÇ INSERT	YEDEK PARÇALAR / SPARE PARTS	
	D	d2	d1	L	M			BASKI VIDASI SCREW	ANAHTAR TORX KEY
HRMDM 0616 HR-M08 Z02	16	8,5	14,5	42	M08	2	WNM.. 06	VRT 04 M2,5x7	T08
HRMDM 0617 HR-M08 Z02	17	8,5	14,5	42	M08	2			
HRMDM 0620 HR-M10 Z02	20	10,5	18	51	M10	2			
HRMDM 0621 HR-M10 Z02	21	10,5	18	51	M10	2			
HRMDM 0625 HR-M12 Z03	25	12,5	23	59	M12	3			
HRMDM 0626 HR-M12 Z03	26	12,5	23	59	M12	3			
HRMDM 0925 HR-M12 Z02	25	12,5	23	59	M12	2	WNM.. 09	VRT 05 M3x8	T10
HRMDM 0926 HR-M12 Z02	26	12,5	23	59	M12	2			
HRMDM 0935 HR-M16 Z04	35	17	29	67	M16	4			
HRMDM 0940 HR-M16 Z04	40	17	29	67	M16	4			
HRMDM 0942 HR-M16 Z04	42	17	29	67	M16	4			

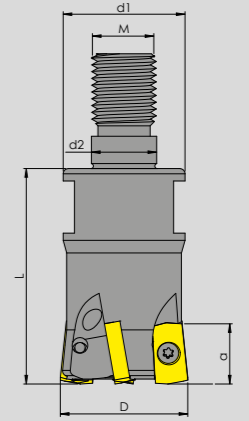

TAKIM KODU ORDERING CODE	TAKIM ÖLÇÜLERİ DIMENSIONS (mm)					KESİCİ UÇ ADET INSERT NUMBER	KESİCİ UÇ INSERT	YEDEK PARÇALAR / SPARE PARTS	
	D	d2	d1	L	M			BASKI VIDASI SCREW	ANAHTAR TORX KEY
MFHLO 25 M12-104T	25	12,5	23	59	M12	2	LO.. 10	VRT 05 M3x8	T10
MFHLO 32 M16-104T	32	17	29	67	M16	3			
MFHLO 40 M16-104T	40	17	29	67	M16	4			

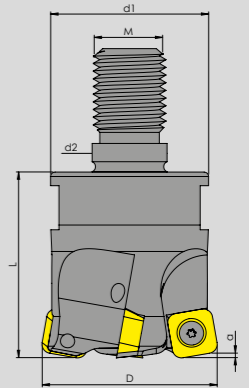

TAKIM KODU ORDERING CODE	TAKIM ÖLÇÜLERİ DIMENSIONS (mm)					KESİCİ UÇ ADET INSERT NUMBER	KESİCİ UÇ INSERT	YEDEK PARÇALAR / SPARE PARTS	
	D	d2	d1	L	M			BASKI VIDASI SCREW	ANAHTAR TORX KEY
MFHSO 32 M16-104T	32	17	29	67	M16	3	SO.. 10	VRT 09 M4x11	T15
MFHSO 40 M16-104T	40	17	29	67	M16	4			

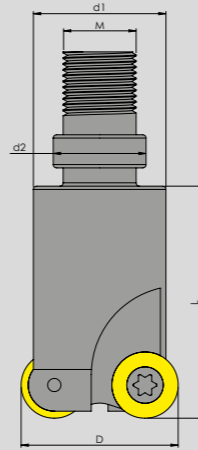

TAKIM KODU ORDERING CODE	TAKIM ÖLÇÜLERİ DIMENSIONS (mm)	KESİCİ UÇ ADET INSERT NUMBER	KESİCİ UÇ INSERT	YEDEK PARÇALAR / SPARE PARTS	
				BASKI VİDASI SCREW	ANAHTAR TORX KEY
VMF RD10	25 H M12 Z03	3	RD.. 1003	VRT 06 M3,5x9	T15
VMF RD10	30 H M16 Z04	4			
VMF RD10	35 H M16 Z04	4			



DELİK DELME VE
TORNALAMA
Hole drilland lathe
www.vorgen.com



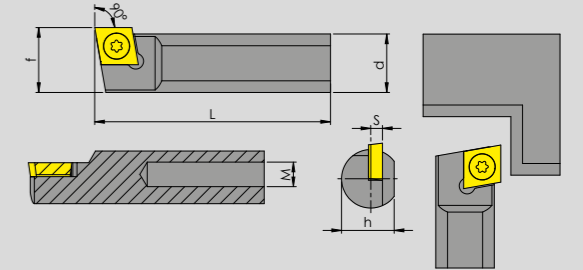
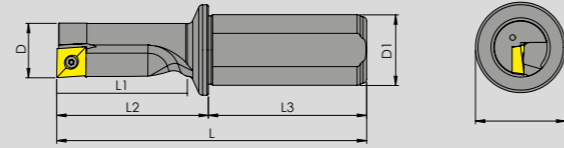

TAKIM KODU ORDERING CODE		TAKIM ÖLÇÜLERİ DIMENSIONS (mm)							KESİCİ UÇ INSERT	YEDEK PARÇALAR / SPARE PARTS	
										BASKI VİDASI SCREW	ANAHTAR TORX KEY
BTMT	10Rx2,25D	L	L1	L2	L3	D	D1	D2			
BTMT	12Rx2,25D	72	22,5	30	42	10	12	16	XC.. 030204	VRT 01 M2x5	T06
BTMT	14Rx2,25D	78	27	33	45	12	16	20	XC.. 060304	VRT 02 M2,2x5	T06
BTMT	16Rx2,25D	83	31,5	38	45	14	16	20	XC.. 070304	VRT 03 M2,5x5	T08
BTMT	16Rx2,25D	94	36	44	50	16	20	25	XC.. 080304	VRT 05 M3x6	T10
BTMT	20Rx2,25D	111	45	55	56	20	25	32	XC.. 10T304	VRT 06 M3,5x9	T15
BTMT	25Rx2,25D	129	56,5	69	60	25	32	40	XC.. 130404	VRT10 M4,5x10	T20

TAKIM KODU ORDERING CODE		TAKIM ÖLÇÜLERİ DIMENSIONS (mm)							KESİCİ UÇ INSERT	YEDEK PARÇALAR / SPARE PARTS	
										BASKI VİDASI SCREW	ANAHTAR TORX KEY
S10A	SCGCR/L 06	d	h	L	S	f	M				
S10B	SCGCR/L 06	10	9	32	1	10	M5	CC.. 0602	VRT 04 M2,5x7	T08	
S10C	SCGCR/L 06	10	9	40	1	10	M5				
S10C	SCGCR/L 06	10	9	50	1	10	M5				
S12A	SCGCR/L 06	12	11	32	1	12	M5				
S12B	SCGCR/L 06	12	11	40	1	12	M5				
S12C	SCGCR/L 06	12	11	50	1	12	M5				
S16A	SCGCR/L 09	16	16	32	2	16	M6x1	CC.. 09T3	VRT 06 M3,5x9	T15	
S16B	SCGCR/L 09	16	16	40	2	16	M6x1				
S16B	SCGCR/L 09	16	16	50	2	16	M6x1				
S16C	SCGCR/L 09	16	16	50	2	16	M6x1				

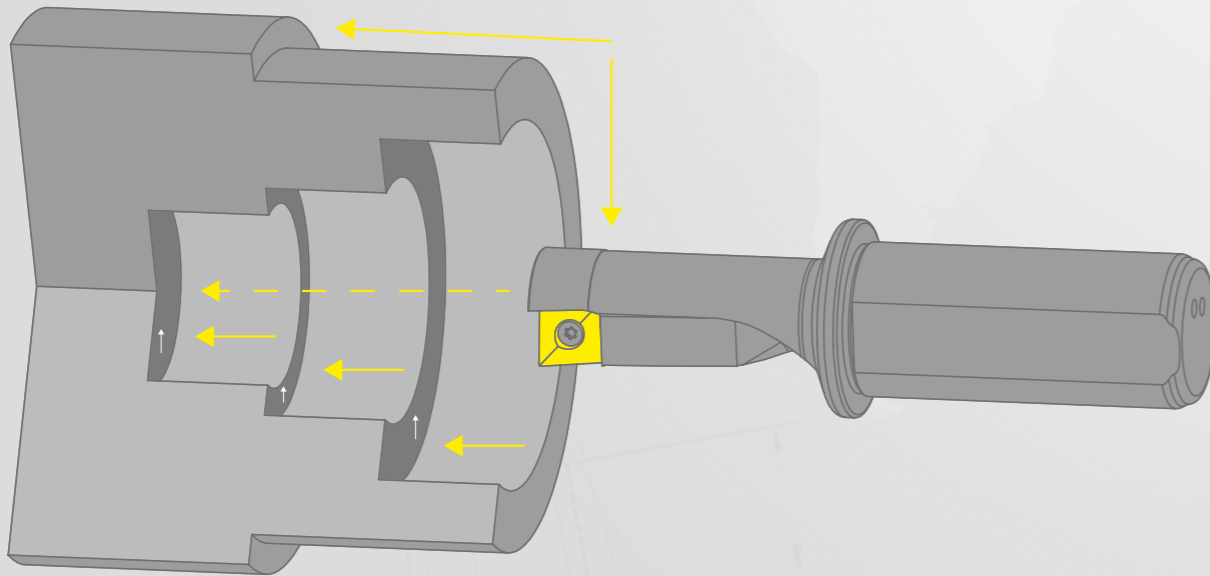

BTDR 2D ÜRÜN / PRODUCT



TEKNİK ÇİZİM / TECHNICAL DRAWING

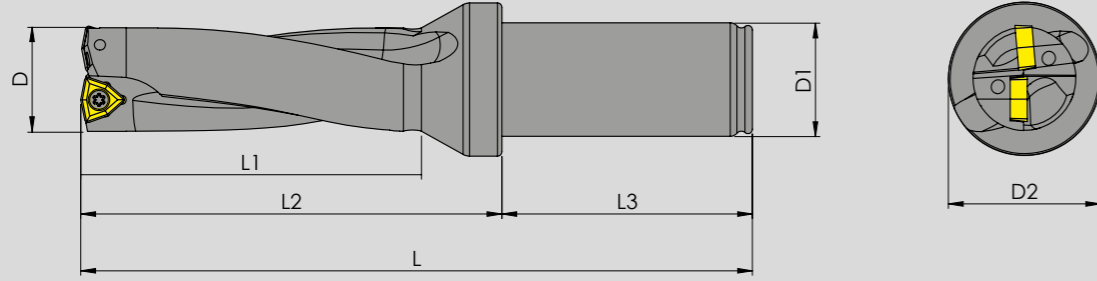

TAKIM KODU ORDERING CODE		TAKIM ÖLÇÜLERİ DIMENSIONS (mm)							KESİCİ UÇ INSERT	YEDEK PARÇALAR / SPARE PARTS	
										BASKI VIDASI SCREW	ANAHTAR TORX KEY
BTDR	2Dx16	108	32	52	56	16	25	34	WCM.. 030208	VRT 02 M2,5x5	T08
BTDR	2Dx16,5	108	33	52	56	16,5	25	34			
BTDR	2Dx17	110	34	54	56	17	25	34			
BTDR	2Dx17,5	110	35	54	56	17,5	25	34			
BTDR	2Dx18	113	36	57	56	18	25	34			
BTDR	2Dx18,5	113	37	57	56	18,5	25	34			
BTDR	2Dx19	115	38	59	56	19	25	34			
BTDR	2Dx19,5	115	39	59	56	19,5	25	34			
BTDR	2Dx20	119	40	63	56	20	25	34			
BTDR	2Dx20,5	119	41	63	56	20,5	25	34			
BTDR	2Dx21	121	42	65	56	21	25	34	WCM.. 040208	VRT 02 M2,5x5	T08
BTDR	2Dx21,5	121	43	65	56	21,5	25	34			
BTDR	2Dx22	123	44	67	56	22	25	34			
BTDR	2Dx22,5	123	45	67	56	22,5	25	34			
BTDR	2Dx23	127	46	71	56	23	25	34			
BTDR	2Dx23,5	127	47	71	56	23,5	25	34			

TAKIM KODU ORDERING CODE		TAKIM ÖLÇÜLERİ DIMENSIONS (mm)							KESİCİ UÇ INSERT	YEDEK PARÇALAR / SPARE PARTS				
										BASKI VIDASI SCREW	ANAHTAR TORX KEY			
BTDR	2Dx24	130	48	74	56	24	25	44	WCM.. 050308	VRT 05 M3x8	T10			
BTDR	2Dx24,5	130	49	74	56	24,5	25	44						
BTDR	2Dx25	133	50	77	56	25	25	44						
BTDR	2Dx25,5	133	51	77	56	25,5	25	44						
BTDR	2Dx26	135	52	79	56	26	25	44						
BTDR	2Dx26,5	135	53	79	56	26,5	25	44						
BTDR	2Dx27	137	54	81	56	27	25	44						
BTDR	2Dx27,5	137	55	81	56	27,5	25	44						
BTDR	2Dx28	140	56	84	56	28	25	44						
BTDR	2Dx28,5	140	57	84	56	28,5	25	44						
BTDR	2Dx29	142	58	86	56	29	25	44				WCM.. 06T308	VRT 06 M3,5x9	T15
BTDR	2Dx29,5	142	59	86	56	29,5	25	44						
BTDR	2Dx30	151	60	91	56	30	32	44						
BTDR	2Dx31	154	61	94	60	31	32	44						
BTDR	2Dx32	156	62	96	60	32	32	44						
BTDR	2Dx33	159	63	99	60	33	32	44						
BTDR	2Dx34	161	64	101	60	34	32	44						
BTDR	2Dx35	164	70	97	60	35	32	44						
BTDR	2Dx36	166	75	99	60	36	32	44						
BTDR	2Dx37	168	74	101	60	37	32	44						
BTDR	2Dx38	170	76	103	60	38	32	44						
BTDR	2Dx39	172	78	105	60	39	32	44						
BTDR	2Dx40	174	80	107	60	40	32	44						
BTDR	2Dx41	176	82	109	60	41	32	44						
BTDR	2Dx42	178	84	111	60	42	32	44						
BTDR	2Dx43	180	86	113	60	43	32	44	WCM.. 080412	VRT 09 M4x11	T15			
BTDR	2Dx44	182	88	115	60	44	32	44						
BTDR	2Dx45	184	90	122	70	45	40	54						
BTDR	2Dx46	186	92	124	70	46	40	54						
BTDR	2Dx47	188	94	126	70	47	40	54						
BTDR	2Dx48	190	96	128	70	48	40	54						
BTDR	2Dx49	192	98	130	70	49	40	54						
BTDR	2Dx50	194	100	132	70	50	40	54						
BTDR	2Dx51	196	102	134	70	51	40	54						
BTDR	2Dx52	198	104	136	70	52	40	54						
BTDR	2Dx53	200	106	138	70	53	40	54						
BTDR	2Dx54	202	108	140	70	54	40	54						
BTDR	2Dx55	204	110	142	70	55	40	54						
BTDR	2Dx56	206	112	144	70	56	40	54						
BTDR	2Dx57	208	114	146	70	57	40	54						
BTDR	2Dx58	210	116	148	70	58	40	54						
BTDR	2Dx59	212	118	150	70	59	40	54						
BTDR	2Dx60	214	120	152	70	60	40	54						

BTDR 3D

ÜRÜN / PRODUCT



TEKNİK ÇİZİM / TECHNICAL DRAWING

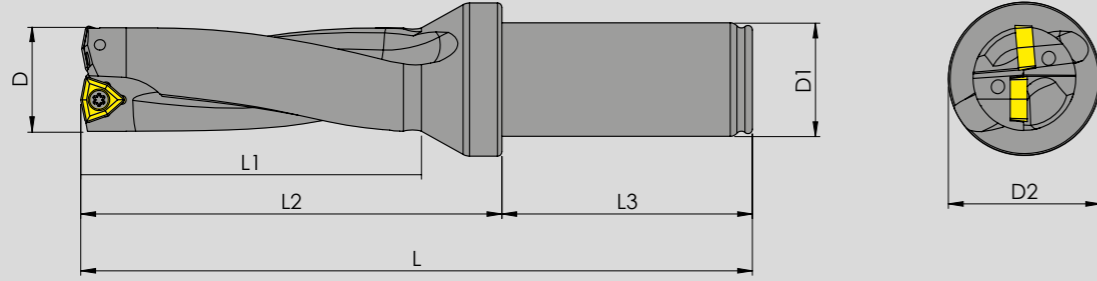

TAKIM KODU ORDERING CODE		TAKIM ÖLÇÜLERİ DIMENSIONS (mm)							KESİCİ UÇ INSERT	YEDEK PARÇALAR / SPARE PARTS	
										BASKI VİDASI SCREW	ANAHTAR TORX KEY
		L	L1	L2	L3	D	D1	D2			
BTDR	3Dx16	124	48	68	56	16	25	34	WCM.. 030208	VRT 02 M2,5x5	T08
BTDR	3Dx16,5	124	48	68	56	16,5	25	34			
BTDR	3Dx17	127	51	71	56	17	25	34			
BTDR	3Dx17,5	127	51	71	56	17,5	25	34			
BTDR	3Dx18	131	54	75	56	18	25	34			
BTDR	3Dx18,5	131	54	75	56	18,5	25	34			
BTDR	3Dx19	134	57	78	56	19	25	34			
BTDR	3Dx19,5	134	57	78	56	19,5	25	34			
BTDR	3Dx20	139	60	83	56	20	25	34	WCM.. 040208	VRT 02 M2,5x5	T08
BTDR	3Dx20,5	139	60	83	56	20,5	25	34			
BTDR	3Dx21	142	63	86	56	21	25	34			
BTDR	3Dx21,5	142	63	86	56	21,5	25	34			
BTDR	3Dx22	145	66	89	56	22	25	34			
BTDR	3Dx22,5	145	66	89	56	22,5	25	34			
BTDR	3Dx23	150	69	94	56	23	25	34			
BTDR	3Dx23,5	150	69	94	56	23,5	25	34			

TAKIM KODU ORDERING CODE		TAKIM ÖLÇÜLERİ DIMENSIONS (mm)							KESİCİ UÇ INSERT	YEDEK PARÇALAR / SPARE PARTS	
										BASKI VİDASI SCREW	ANAHTAR TORX KEY
		L	L1	L2	L3	D	D1	D2			
BTDR	3Dx24	154	72	98	56	24	25	44	WCM.. 050308	VRT 05 M3x8	T10
BTDR	3Dx24,5	154	72	98	56	24,5	25	44			
BTDR	3Dx25	158	75	102	56	25	25	44			
BTDR	3Dx25,5	158	75	102	56	25,5	25	44			
BTDR	3Dx26	161	78	105	56	26	25	44			
BTDR	3Dx26,5	161	78	105	56	26,5	25	44			
BTDR	3Dx27	164	81	108	56	27	25	44			
BTDR	3Dx27,5	164	81	108	56	27,5	25	44			
BTDR	3Dx28	168	84	112	56	28	25	44			
BTDR	3Dx28,5	168	84	112	56	28,5	25	44			
BTDR	3Dx29	171	87	115	56	29	25	44			
BTDR	3Dx29,5	171	87	115	56	29,5	25	44			
BTDR	3Dx30	180	90	121	56	30	32	44	WCM.. 06T308	VRT 06 M3,5x9	T15
BTDR	3Dx31	181	93	125	60	31	32	44			
BTDR	3Dx32	188	96	128	60	32	32	44			
BTDR	3Dx33	192	99	132	60	33	32	44			
BTDR	3Dx34	195	102	135	60	34	32	44			
BTDR	3Dx35	192	105	132	60	35	32	44			
BTDR	3Dx36	195	108	135	60	36	32	44			
BTDR	3Dx37	198	111	138	60	37	32	44			
BTDR	3Dx38	201	114	141	60	38	32	44			
BTDR	3Dx39	204	117	144	60	39	32	44			
BTDR	3Dx40	207	120	147	60	40	32	44			
BTDR	3Dx41	210	123	150	60	41	32	44			
BTDR	3Dx42	213	126	153	60	42	32	44	WCM.. 080412	VRT 09 M4x11	T15
BTDR	3Dx43	216	129	156	60	43	32	44			
BTDR	3Dx44	219	132	159	60	44	32	44			
BTDR	3Dx45	237	135	167	70	45	40	54			
BTDR	3Dx46	240	138	170	70	46	40	54			
BTDR	3Dx47	243	141	173	70	47	40	54			
BTDR	3Dx48	246	144	176	70	48	40	54			
BTDR	3Dx49	249	147	179	70	49	40	54			
BTDR	3Dx50	252	150	182	70	50	40	54			
BTDR	3Dx51	255	153	185	70	51	40	54			
BTDR	3Dx52	258	156	188	70	52	40	54			
BTDR	3Dx53	261	159	191	70	53	40	54			
BTDR	3Dx54	264	162	194	70	54	40	54			
BTDR	3Dx55	267	165	197	70	55	40	54			
BTDR	3Dx56	270	168	200	70	56	40	54			
BTDR	3Dx57	273	171	203	70	57	40	54			
BTDR	3Dx58	276	174	206	70	58	40	54			
BTDR	3Dx59	279	177	209	70	59	40	54			
BTDR	3Dx60	282	180	212	70	60	40	54			

BTDR 4D

ÜRÜN / PRODUCT



TEKNİK ÇİZİM / TECHNICAL DRAWING

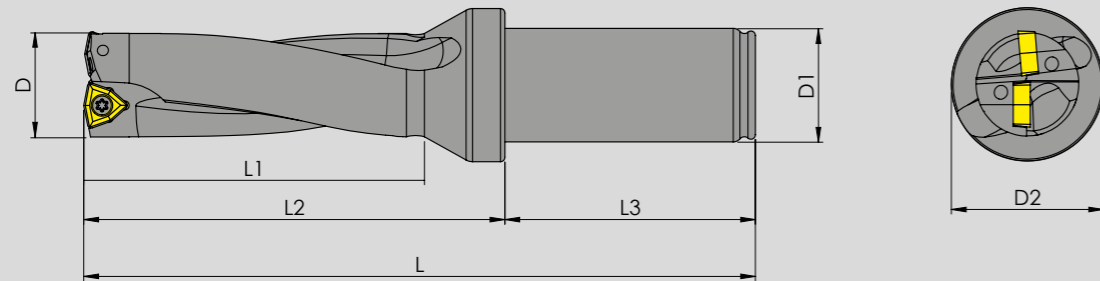

TAKIM KODU ORDERING CODE		TAKIM ÖLÇÜLERİ DIMENSIONS (mm)							KESİCİ UÇ INSERT	YEDEK PARÇALAR / SPARE PARTS	
		L	L1	L2	L3	D	D1	D2		BASKI VİDASI SCREW	ANAHTAR TORX KEY
BTDR	4Dx16	142	64	86	56	16	25	34	WCM.. 030208	VRT 02 M2,5x5	T08
BTDR	4Dx16,5	142	64	86	56	16,5	25	34			
BTDR	4Dx17	146	68	90	56	17	25	34			
BTDR	4Dx17,5	146	68	90	56	17,5	25	34			
BTDR	4Dx18	150	72	94	56	18	25	34			
BTDR	4Dx18,5	150	72	94	56	18,5	25	34			
BTDR	4Dx19	154	76	98	56	19	25	34			
BTDR	4Dx19,5	154	76	98	56	19,5	25	34			
BTDR	4Dx20	158	80	102	56	20	25	34			
BTDR	4Dx20,5	158	80	102	56	20,5	25	34			
BTDR	4Dx21	162	84	106	56	21	25	34	WCM.. 040208	VRT 02 M2,5x5	T08
BTDR	4Dx21,5	162	84	106	56	21,5	25	34			
BTDR	4Dx22	166	88	110	56	22	25	34			
BTDR	4Dx22,5	166	88	110	56	22,5	25	34			
BTDR	4Dx23	170	92	114	56	23	25	34			
BTDR	4Dx23,5	170	92	114	56	23,5	25	34			
BTDR	4Dx24	174	96	118	56	24	25	44			
BTDR	4Dx24,5	174	96	118	56	24,5	25	44			
BTDR	4Dx25	178	100	122	56	25	25	44			
BTDR	4Dx25,5	178	100	122	56	25,5	25	44			
BTDR	4Dx26	182	104	126	56	26	25	44	WCM.. 050308	VRT 05 M3x8	T10
BTDR	4Dx26,5	182	104	126	56	26,5	25	44			
BTDR	4Dx27	186	108	130	56	27	25	44			
BTDR	4Dx27,5	186	108	130	56	27,5	25	44			
BTDR	4Dx28	190	112	134	56	28	25	44			
BTDR	4Dx28,5	190	112	134	56	28,5	25	44			
BTDR	4Dx29	194	116	138	56	29	25	44			
BTDR	4Dx29,5	194	116	138	56	29,5	25	44			
BTDR	4Dx30	207	120	147	60	30	32	44			
BTDR	4Dx31	211	124	151	60	31	32	44			
BTDR	4Dx32	215	128	155	60	32	32	44	WCM.. 06T308	VRT 06 M3,5x9	T15
BTDR	4Dx33	219	132	159	60	33	32	44			
BTDR	4Dx34	223	136	163	60	34	32	44			
BTDR	4Dx35	227	140	167	60	35	32	44			
BTDR	4Dx36	231	144	171	60	36	32	44			
BTDR	4Dx37	235	148	175	60	37	32	44			
BTDR	4Dx38	239	152	179	60	38	32	44			
BTDR	4Dx39	243	156	183	60	39	32	44			
BTDR	4Dx40	247	160	187	60	40	32	44			
BTDR	4Dx41	251	164	191	60	41	32	44			
BTDR	4Dx42	255	168	195	60	42	32	44			
BTDR	4Dx43	259	172	199	60	43	32	44			
BTDR	4Dx44	263	176	203	60	44	32	44			

BTDR 5D

ÜRÜN / PRODUCT



TAKIM KODU ORDERING CODE		TAKIM ÖLÇÜLERİ DIMENSIONS (mm)							KESİCİ UÇ INSERT	YEDEK PARÇALAR / SPARE PARTS	
										BASKI VİDASI SCREW	ANAHTAR TORX KEY
BTDR	5Dx16	156	80	68	56	16	25	34	WCM.. 030208	VRT 02 M2,5x5	T08
BTDR	5Dx17	161	85	71	56	17	25	34			
BTDR	5Dx18	167	90	75	56	18	25	34			
BTDR	5Dx19	172	95	78	56	19	25	34			
BTDR	5Dx20	179	100	83	56	20	25	34	WCM.. 040208	VRT 02 M2,5x5	T08
BTDR	5Dx21	184	105	86	56	21	25	34			
BTDR	5Dx22	189	110	89	56	22	25	34			
BTDR	5Dx23	193	115	94	56	23	25	24			
BTDR	5Dx24	198	120	98	56	24	25	44	WCM.. 050308	VRT 05 M3x8	T10
BTDR	5Dx25	203	125	102	56	25	25	44			
BTDR	5Dx26	207	130	105	56	26	25	44			
BTDR	5Dx27	211	135	108	56	27	25	44			
BTDR	5Dx28	216	140	112	56	28	25	44			
BTDR	5Dx29	220	145	115	56	29	25	44			
BTDR	5Dx30	224	150	121	60	30	32	44	WCM.. 06T308	VRT 06 M3,5x9	T15
BTDR	5Dx31	245	155	125	60	31	32	44			
BTDR	5Dx32	250	160	128	60	32	32	44			
BTDR	5Dx33	255	165	132	60	33	32	44			
BTDR	5Dx34	260	170	135	60	34	32	44			

TEKNİK ÇİZİM / TECHNICAL DRAWING

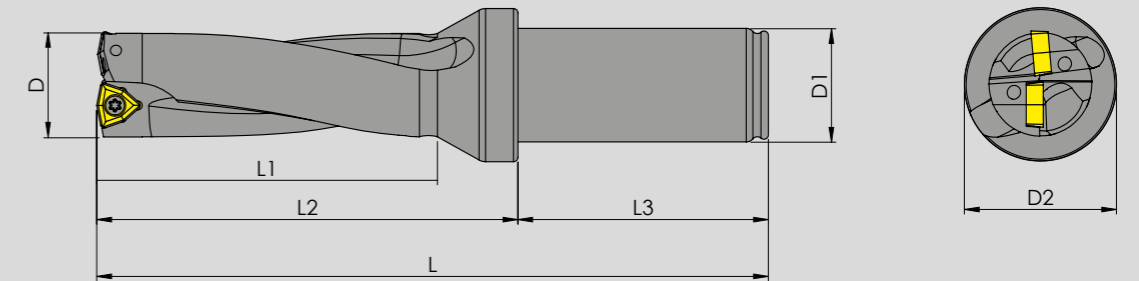

BTDR 2D

ÜRÜN / PRODUCT



TAKIM KODU ORDERING CODE		TAKIM ÖLÇÜLERİ DIMENSIONS (mm)							KESİCİ UÇ INSERT	YEDEK PARÇALAR / SPARE PARTS	
		L	L1	L2	L3	D	D1	D2		BASKI VIDASI SCREW	ANAHTAR TORX KEY
BTDR	2Dx13	98	26	48	50	13	20	25	SPMG.. 050204	VRT 01 M2x5	T06
BTDR	2Dx14	100	28	50	50	14	20	25			
BTDR	2Dx15	102	30	52	50	15	20	25			
BTDR	2Dx16	110	32	54	56	16	25	34	SPMG.. 060204	VRT 02 M2,2x5	T06
BTDR	2Dx17	111	34	56	56	17	25	34			
BTDR	2Dx18	114	36	58	56	18	25	34			
BTDR	2Dx19	116	38	60	56	19	25	34			
BTDR	2Dx20	118	40	62	56	20	25	34			
BTDR	2Dx21	120	42	64	56	21	25	34	SPMG.. 07T0308	VRT 03 M2,5x5	T08
BTDR	2Dx22	122	44	66	56	22	25	34			
BTDR	2Dx23	124	46	68	56	23	25	34			
BTDR	2Dx24	126	48	70	56	24	25	34			
BTDR	2Dx25	128	50	72	56	25	25	34			
BTDR	2Dx26	130	52	74	56	26	25	34	SPMG.. 090408	VRT 06 M3,5x9	T15
BTDR	2Dx27	132	54	76	56	27	25	34			
BTDR	2Dx28	134	56	78	56	28	25	34			
BTDR	2Dx29	136	58	80	56	29	25	34			
BTDR	2Dx30	147	60	87	60	30	32	44			
BTDR	2Dx31	149	62	89	60	31	32	44	SPMG.. 110408	VRT 09 M4x11	T15
BTDR	2Dx32	151	64	91	60	32	32	44			
BTDR	2Dx33	153	66	93	60	33	32	44			
BTDR	2Dx34	155	68	95	60	34	32	44			
BTDR	2Dx35	157	70	97	60	35	32	44			
BTDR	2Dx36	159	72	99	60	36	32	44	SPMG.. 110408	VRT 09 M4x11	T15
BTDR	2Dx37	161	74	101	60	37	32	44			
BTDR	2Dx38	153	76	103	60	38	32	44			
BTDR	2Dx39	165	78	105	60	39	32	44			
BTDR	2Dx40	167	80	107	60	40	32	44			
BTDR	2Dx41	169	82	109	60	41	32	44			

TEKNİK ÇİZİM / TECHNICAL DRAWING

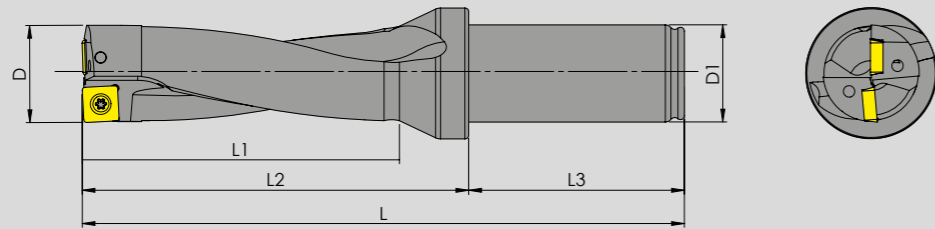

BTDR 3D

ÜRÜN / PRODUCT



TAKIM KODU ORDERING CODE		TAKIM ÖLÇÜLERİ DIMENSIONS (mm)							KESİCİ UÇ INSERT	YEDEK PARÇALAR / SPARE PARTS	
		L	L1	L2	L3	D	D1	D2		BASKI VİDASI SCREW	ANAHTAR TORX KEY
BTDR	3Dx13	111	39	61	50	13	20	25	SPMG.. 050204	VRT 01 M2x5	T06
BTDR	3Dx14	114	42	64	50	14	20	25			
BTDR	3Dx15	117	45	67	50	15	20	25			
BTDR	3Dx16	126	48	70	56	16	25	3	SPMG.. 060204	VRT 02 M2,2x5	T06
BTDR	3Dx17	129	51	73	56	17	25	34			
BTDR	3Dx18	132	54	76	56	18	25	34			
BTDR	3Dx19	135	57	79	56	19	25	34			
BTDR	3Dx20	135	60	82	56	20	25	34			
BTDR	3Dx21	141	63	85	56	21	25	34			
BTDR	3Dx22	144	66	88	56	22	25	34	SPMG.. 07T0308	VRT 03 M2,5x5	T08
BTDR	3Dx23	147	69	91	56	23	25	34			
BTDR	3Dx24	150	72	94	56	24	25	34			
BTDR	3Dx25	153	75	97	56	25	25	34			
BTDR	3Dx26	156	78	100	56	26	25	34			
BTDR	3Dx27	159	81	103	56	27	25	34	SPMG.. 090408	VRT 06 M3,5x9	T15
BTDR	3Dx28	162	84	106	56	28	25	34			
BTDR	3Dx29	165	87	109	56	29	25	34			
BTDR	3Dx30	177	90	117	60	30	32	44			
BTDR	3Dx31	180	93	120	60	31	32	44			
BTDR	3Dx32	183	96	123	60	32	32	44			
BTDR	3Dx33	186	99	126	60	33	32	44	SPMG.. 110408	VRT 09 M4x11	T15
BTDR	3Dx34	189	102	129	60	34	32	44			
BTDR	3Dx35	192	105	132	60	35	32	44			
BTDR	3Dx36	195	108	135	60	36	32	44			
BTDR	3Dx37	198	111	138	60	37	32	44			
BTDR	3Dx38	201	114	141	60	38	32	44			
BTDR	3Dx39	204	117	144	60	39	32	44			
BTDR	3Dx40	2017	120	147	60	40	32	44			
BTDR	3Dx41	210	123	120	60	41	32	44			

TEKNİK ÇİZİM / TECHNICAL DRAWING

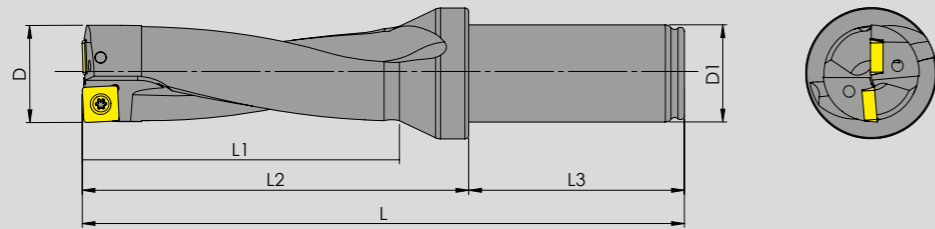

BTDR 4D

ÜRÜN / PRODUCT



TAKIM KODU ORDERING CODE		TAKIM ÖLÇÜLERİ DIMENSIONS (mm)							KESİCİ UÇ INSERT	YEDEK PARÇALAR / SPARE PARTS	
		L	L1	L2	L3	D	D1	D2		BASKI VIDASI SCREW	ANAHTAR TORX KEY
BTDR	4Dx13	124	52	74	50	13	20	25	SPMG.. 050204	VRT 01 M2x5	T06
BTDR	4Dx14	128	56	78	50	14	20	25			
BTDR	4Dx15	132	60	82	50	15	20	25			
BTDR	4Dx16	142	64	86	56	16	25	34	SPMG.. 060204	VRT 02 M2,2x5	T06
BTDR	4Dx17	146	68	90	56	17	25	34			
BTDR	4Dx18	150	72	94	56	18	25	34			
BTDR	4Dx19	154	76	98	56	19	25	34			
BTDR	4Dx20	158	80	102	56	20	25	34			
BTDR	4Dx21	162	84	106	56	21	25	34	SPMG.. 07T0308	VRT 03 M2,5x5	T08
BTDR	4Dx22	166	88	110	56	22	25	34			
BTDR	4Dx23	170	92	114	56	23	25	34			
BTDR	4Dx24	174	96	118	56	24	25	34			
BTDR	4Dx25	178	100	122	56	25	25	34			
BTDR	4Dx26	182	104	126	56	26	25	34	SPMG.. 090408	VRT 06 M3,5x9	T15
BTDR	4Dx27	186	108	130	56	27	25	34			
BTDR	4Dx28	190	112	134	56	28	25	34			
BTDR	4Dx29	194	116	138	56	29	25	34			
BTDR	4Dx30	207	120	147	60	30	32	44			
BTDR	4Dx31	211	124	151	60	31	32	44	SPMG.. 110408	VRT 09 M4x11	T15
BTDR	4Dx32	215	128	155	60	32	32	44			
BTDR	4Dx33	219	132	159	60	33	32	44			
BTDR	4Dx34	223	136	163	60	34	32	44			
BTDR	4Dx35	227	140	167	60	35	32	44			
BTDR	4Dx36	231	144	171	60	36	32	44	SPMG.. 110408	VRT 09 M4x11	T15
BTDR	4Dx37	235	148	175	60	37	32	44			
BTDR	4Dx38	239	152	179	60	38	32	44			
BTDR	4Dx39	243	156	183	60	39	32	44			
BTDR	4Dx40	247	160	187	60	40	32	44			
BTDR	4Dx41	251	164	191	60	41	32	44			

TEKNİK ÇİZİM / TECHNICAL DRAWING

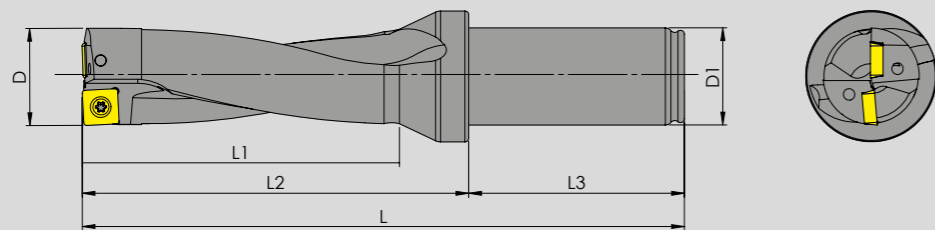



TEKNİK ÇİZİM / TECHNICAL DRAWING

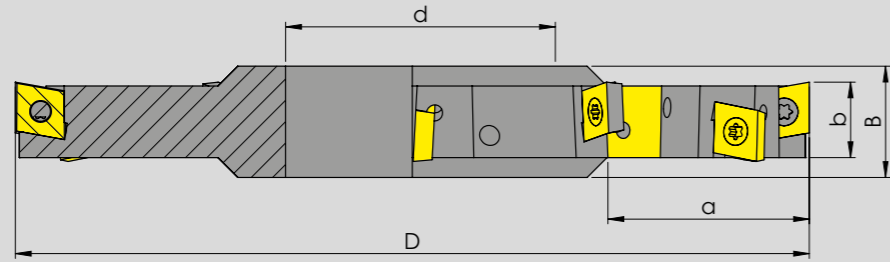

TAKIM KODU ORDERING CODE	TAKIM ÖLÇÜLERİ DIMENSIONS (mm)								KESİCİ UÇ INSERT	YEDEK PARÇALAR / SPARE PARTS	
	Z	Z1	D	b	a	d	B	BASKI VIDASI SCREW		ANAHTAR TORX KEY	
VRDF D80x8 d27-Z10	10	5	80	8	17	27	12	CC.. 0602	VRT 04 M2,5x5	T08	
VRDF D100x8 d32-Z12	12	6	100	8	25	32	12				
VRDF D125x8 d40-Z14	14	7	125	8	35	40	12				
VRDF D80x10 d27-Z10	10	5	80	10	17	27	14				
VRDF D100x10 d32-Z12	12	6	100	10	25	32	14				
VRDF D125x10 d40-Z14	14	7	125	10	35	40	14				
VRDF D80x12 d27-Z10	8	4	80	12	17	27	16	CC.. 09T3	VRT 06 M3,5x9	T15	
VRDF D100x12 d32-Z12	10	5	100	12	25	32	16				
VRDF D125x12 d40-Z14	12	6	125	12	35	40	16				
VRDF D80x14 d27-Z08	8	4	80	14	17	27	18				
VRDF D100x14 d32-Z10	10	5	100	14	25	32	18				
VRDF D125x14 d40-Z12	12	6	125	14	35	40	18				
VRDF D80x16 d27-Z10	6	3	80	16	17	27	20	CC.. 1204	VRT 10 M4,5x12	T20	
VRDF D100x16 d32-Z12	8	4	100	16	25	32	20				
VRDF D125x16 d40-Z14	10	5	125	16	35	40	20				
VRDF D80x18 d27-Z10	6	3	80	18	17	27	22				
VRDF D100x18 d32-Z12	8	4	100	18	25	32	22				
VRDF D125x18 d40-Z14	10	5	125	18	35	40	22				
VRDF D80x20 d27-Z10	6	3	80	20	17	27	24	CC.. 1204	VRT 10 M4,5x12	T20	
VRDF D100x20 d32-Z12	8	4	100	20	25	32	24				
VRDF D125x20 d40-Z14	10	5	125	20	35	40	24				
VRDF D125x20 d40-Z14	10	5	125	20	35	40	24				



TEKNİK ÇİZİM / TECHNICAL DRAWING





TAKIM KODU ORDERING CODE	TAKIM ÖLÇÜLERİ DIMENSIONS (mm)									KESİCİ UÇ INSERT	YEDEK PARÇALAR / SPARE PARTS	
	Z	Z1	D	B	D	L	D1	D2	BASKI VIDASI SCREW		ANAHTAR TORX KEY	
SPTF D17x8 d16 Z02 L100	2	1	17	8	16	100	10	16	CC.. 0602	VRT 04 M2,5x5	T08	
SPTF D20x9 d16 Z02 L100	4	2	20	9	16	100	10	16				
SPTF D25x11 d20 Z04 L100	4	2	25	11	25	100	13	20				
SPTF D32x12 d20 Z04 L100	2	1	32	12	25	100	16	25				
SPTF D35x15 d25 Z04 L100	4	2	35	16	25	100	17	30				
SPTF D40x17 d25 Z04 L120	4	2	40	17	32	120	19	30				
SPTF D50x22 d32 Z04 L120	4	2	50	22	32	120	25	45	CC.. 1204	VRT 10 M4,5x12	T20	
SPTF D52x21 d32 Z04 L120	4	2	52	21	32	120	25	45				

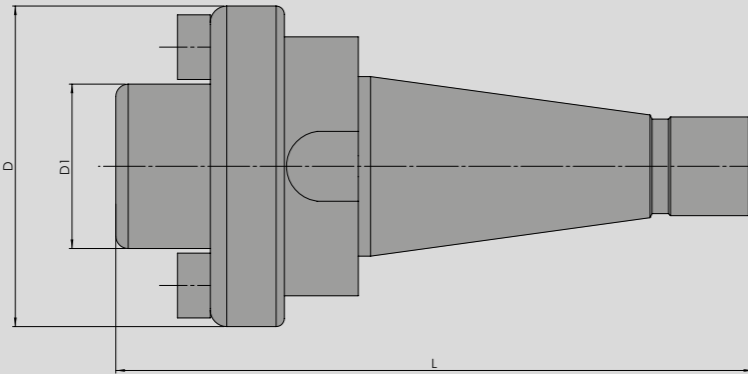

TEKNİK ÇİZİM / TECHNICAL DRAWING



TAKIM KODU ORDERING CODE		TAKIM ÖLÇÜLERİ DIMENSIONS (mm)			YEDEK PARÇALAR / SPARE PARTS	
					BASKI VIDASI SCREW	ANAHTAR ALLEN KEY
ISO	30-Q16	D	d1	L		
ISO	30-Q16	39	16	125	VR08 M8	AA6
ISO	30-Q22	48	22	125	VR09 M10	AA8
ISO	30-Q32	66	32	125	VR10 M16	AA14
ISO	40-Q16	39	16	154	VR08 M8	AA6
ISO	40-Q22	50	22	154	VR09 M10	AA8
ISO	40-Q27	66	27	154	VR11 M12	AA10
ISO	40-Q32	66	32	154	VR10 M16	AA14
ISO	40-Q40	72	40	154	VR12 M20	AA17

**YEDEK
PARÇALAR**
Spare parts

www.vorgen.com



The red power for
the professionals
Profesyoneler için
Kırmızı Güç

BASKI PAPUÇLARI / WEDGE CLAMP

ÜRÜN KODU ORDER CODE	ÜRÜN DETAYI DETAILS PRODUCT	ÜRÜN RESMİ PRODUCT OF PICTURE
VDP 01	D SİSTEM İÇİN DNMG 11, WNMG 06, TNMG 16	
VDP 02	D SİSTEM İÇİN TNMG22, DNMG 15, CNMG 12, SNMG12, WNM 08,	
VDP 03	D SİSTEM İÇİN VNMG 16	
VDP 04	D SİSTEM İÇİN CNMG16, SNMG 15	
VDP 05	D SİSTEM İÇİN CNMG 19, SNG 19	
VMP 01	M SİSTEM İÇİN WNMG 06	
VMP02	M SİSTEM İÇİN WNMG 08	
VMP 03	M SİSTEM İÇİN TNMG 16	
VMP 04	M SİSTEM İÇİN TNMG 22	
VCP 01	C SİSTEM İÇİN KNUX-R (ORJİNAL)	
VCP 02	C SİSTEM İÇİN KNUX-L (ORJİNAL)	
VCP 03	C SİSTEM İÇİN 154.91, IR 16, ER 16, IR 22, ER 22, TPKN 16	
VCP 04	C SİSTEM İÇİN TPKN 22	
VCP 05	C SİSTEM İÇİN KNUX-R	
VCP 06	C SİSTEM İÇİN KNUX-L	
VCP 07	C SİSTEM İÇİN SERAMİK CNGN, SNGM, DNGN	
VKP 01	BKT-R390 İÇİN R390 HRN	
VSP 01	SPKN TAR. İÇİN SPKN SET	

ALTLIKLAR / SHIMS

ÜRÜN KODU ORDER CODE	ÜRÜN DETAYI DETAILS PRODUCT	ÜRÜN RESMİ PRODUCT OF PICTURE
VRTC 16	S SİSTEM İÇİN TCMT 16	
VRTN 16	D SİSTEM İÇİN M SİSTEM İÇİN TNMG 16	
VRTN 22	D SİSTEM İÇİN M SİSTEM İÇİN TNMG 22	
VRTN 2202	S25S M SİSTEM İÇİN TNMG 22	
VRIR 16	VİDA 16 ALTLIK IR 16, ER 16	
VRIR 22	VİDA 22 ALTLIK IR 22, ER 22	
VRCM 09	S SİSTEM İÇİN CCMT 09	
VRCN 12	D SİSTEM İÇİN C SİSTEM İÇİN CNMG 12, CNGN 12	
VRCN 16	D SİSTEM İÇİN CNMG 16	
VRCN 19	D SİSTEM İÇİN CNMG 19	
VRWN 08	D SİSTEM İÇİN M SİSTEM İÇİN WNMG 08	
VRKN 16L	C SİSTEM İÇİN KNUX-L 16	
VRKN 16R	C SİSTEM İÇİN KNUX-R 16	
VRSC 12	S SİSTEM İÇİN SCMT 12	
VRSN 12	D SİSTEM İÇİN C SİSTEM İÇİN SNMG 12, SNMN 12	
VRTP 22	TP 22 TAR. İÇİN TPKN 22	

ALTLIKLAR / SHIMS			
ÜRÜN KODU ORDER CODE	ÜRÜN DETAYI DETAILS PRODUCT		ÜRÜN RESMİ PRODUCT OF PICTURE
VRSN 15	D SİSTEM İÇİN	SNMG 15	
VRSN 19	D SİSTEM İÇİN	SNMG 19	
VRDC 11	S SİSTEM İÇİN D SİSTEM İÇİN	DNMG 11, DCMT 11	
VRDN 15	D SİSTEM İÇİN	DNMG 15	
VRVB 16	S SİSTEM İÇİN D SİSTEM İÇİN	VBMT 16, VCMT 16, VNMG 16	

BASKI PAPUÇ VIDALARI / CLAMP SCREW			
ÜRÜN KODU ORDER CODE	ÜRÜN DETAYI DETAILS PRODUCT		ÜRÜN RESMİ PRODUCT OF PICTURE
VRV 01-M5	D SİSTEM İÇİN M SİSTEM İÇİN	DNMG 11, TNMG 16, WNMG 06	
VRV 02-M6	D SİSTEM İÇİN M SİSTEM İÇİN	CNMG 12, TNMG 22, DNMG 15, SNMG 12, TNMG 22, VNMG 16, WNMG 08	
VRV 03-M6	D SİSTEM İÇİN	CNMG 19, SNMG 15, SNMG 19, CNMG 16	
VRV 04-M6	C SİSTEM İÇİN	KNUX 16	
VRV 05-M8	C SİSTEM İÇİN	DNGN, TNGN, SNGN	
VRV 001-M6	TARAMA İÇİN	TPKN 16	
VRV 002-M8	TARAMA İÇİN	TPKN 22	
VRV 003-M8	TARAMA İÇİN	SPKN 12 (SOL)	
VRV 06-M8	KANAL KATERİ İÇİN	JD, HTN, KRY, SD S123, ZCC..	

ALTLIK VIDALARI / SHIMS SCREWS			
ÜRÜN KODU ORDER CODE	ÜRÜN DETAYI DETAILS PRODUCT		ÜRÜN RESMİ PRODUCT OF PICTURE
VAV 01-M3	C SİSTEM İÇİN	KNUX 16	
VAV 02-M5	D SİSTEM İÇİN	DNMG 15, SNMG 12, TNMG 22, WNMG 08, CNMG 12	
VAV 03-M4	D SİSTEM İÇİN	DNMG 11	
VAV 04-M5	D SİSTEM İÇİN	CNMG 16, SNMG 15	
VAV 05-M6	D SİSTEM İÇİN	CNMG 19, SNMG 19	
VAV 06-M5.05	S SİSTEM İÇİN	VBMT 16, ER 16, IR 16, TCMT 16, CCMT 09, DCMT 11, VCMT 16, BUKSE VİDA 3,5	
VAV 07-M6	S SİSTEM İÇİN	ER 22, SCMT 12, BUKSE VİDA 4,5	
VAV 08-M5	M SİSTEM İÇİN	TNMG 16, WNMG 06	
VAV 09-M5	M SİSTEM İÇİN	S 20, MTUNR 16 İÇİN VİDALI PİM	
VAV 10-M6	M SİSTEM İÇİN	WNMG 08, TNMG 22	
VTP 005	TIRTIR İÇİN		

BASKI YAY / SPRING			
ÜRÜN KODU ORDER CODE	ÜRÜN DETAYI DETAILS PRODUCT		ÜRÜN RESMİ PRODUCT OF PICTURE
VRY 01	D SİSTEM İÇİN	WNMG 16, WNMG 08, TNMG 22, DNMG 15, CNMG 12	
VRY 02	C SİSTEM İÇİN	KNUX 16	

YEDEK PARÇALARDA İSKONTO ORANI FARKLIDIR.
YOU HAVE THE DIFFERENT DISCOUNT ON THE SPARE PARTS.

TORX VİDALARI / TORX SCREWS

ÜRÜN KODU ORDER CODE	ÜRÜN DETAYI DETAILS PRODUCT	ÜRÜN RESMİ PRODUCT OF PICTURE
VRT 01-M2x5		
VRT 02-M2,2x5		
VRT 03-M2,5x5		
VRT 04-M2,5x5		
VRT 05-M3x8		
VRT 06-M3,5x9		
VRT 07-M3,5x11		
VRT 08-M3,5x16		
VRT 09-M4x11		
VRT 10-M4,5x12		
VRT 11-M4,5x16		
VRT 12-M6x16		

KÜRE VİDALARI / BALL SCREW

ÜRÜN KODU ORDER CODE	ÜRÜN DETAYI DETAILS PRODUCT	ÜRÜN RESMİ PRODUCT OF PICTURE
VKV 01-M3		
VKV 02-M4		
VKV 03-M5		
VKV 04-M5		
VKV 05-M6		
VKV 06-M8		

ALYAN ANAHTARLARI / ALLEN KEYS

ÜRÜN KODU ORDER CODE	ÜRÜN DETAYI DETAILS PRODUCT	ÜRÜN RESMİ PRODUCT OF PICTURE
AA4		
AA3		
AA4		
AA5		
AA6		

YEDEK PARÇALARDA İSKONTO ORANI FARKLIDIR.
YOU HAVE THE DIFFERENT DISCOUNT ON THE SPARE PARTS.

YEDEK PARÇALARDA İSKONTO ORANI FARKLIDIR.
YOU HAVE THE DIFFERENT DISCOUNT ON THE SPARE PARTS.



The red power for
the professionals
Profesyoneller için
Kırmızı Güç



The **red** power for
the professionals
Profesyoneler için
Kırmızı Güç

KONIA İSMAT



VORGEN[®]

bahçıvan
Makina Sanayi ve Ticaret



Tel: +90 332 345 09 66
Tel: +90 332 345 09 67
Fax: +90 332 345 06 42

Büsan Özel Organize San. Çelik Cad.
No: 43 Karatay / KONYA / TURKEY
www.vorgen.com

info@vorgen.com
export@vorgen.com